

CHECK VALVES - RESILIENT SEATED

SHORT VERSION

[Click here](#) for complete version of this catalogue

UNIFLO[®]

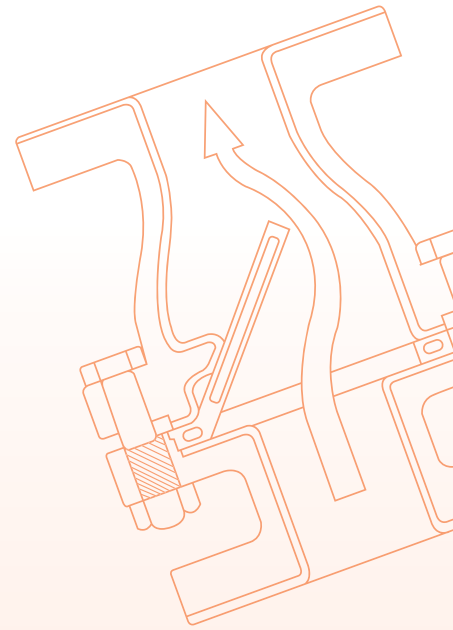
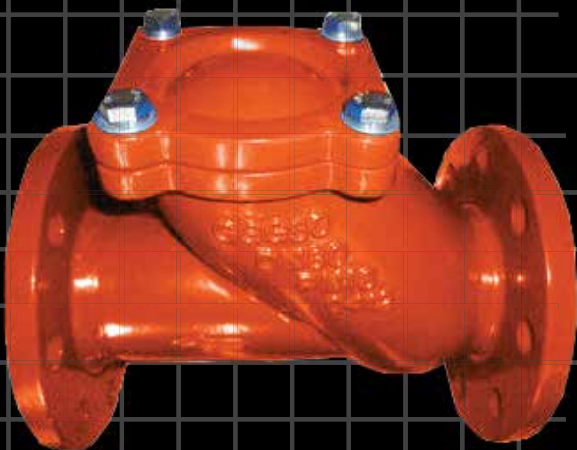

**AUSTRALIAN
PIPELINE VALVE[®]**

www.australianpipelinevalve.com.au

QUALITY VALVE MANUFACTURER

QUALITY COMMITMENT

Quality is Our First Priority.

Consistent product quality and a proven track record makes Australian Pipeline Valve a dependable choice where total reliability is the number one concern.

Since its founding, APV's philosophy has been focused on quality. Our valves are manufactured in full compliance to worldwide standards (such as ASME/ANSI, API, EN, ISO, BS, AS).

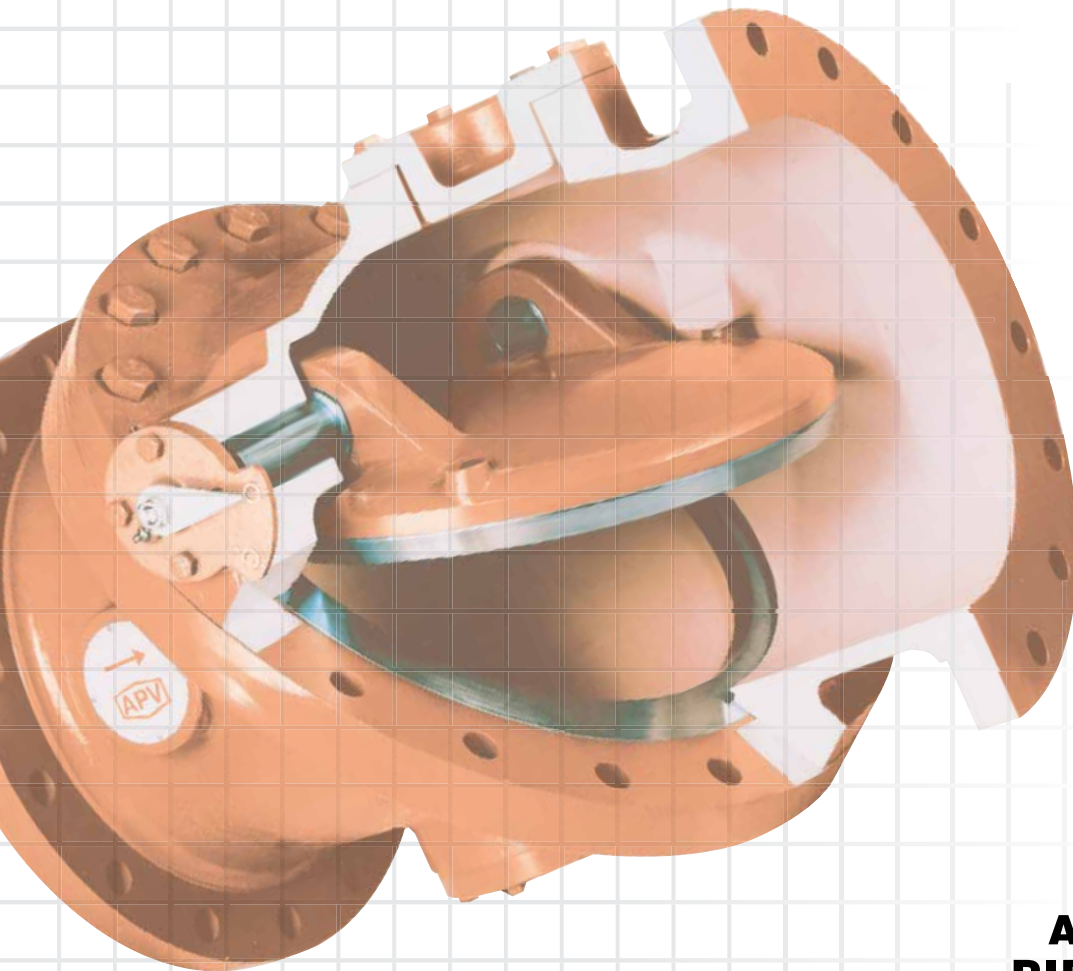

**AUSTRALIAN
PIPELINE VALVE®**

70-78 Stanbel Road Salisbury Plain South Australia 5109
Telephone +61 (0)8 8285 0033
email: admin@australianpipelinevalve.com.au

www.australianpipelinevalve.com.au

CONTENTS - SHORT VERSION*

Check Valve (Non Return) - APN Series	4
Check Valve (Non Return) - APNX Series	5
Lined Ball Check Valve - DO Series	6~7*
Flanged Ball Check Valve - BC Series	8
Swing Check Valve with Lever & Counterweight	9
Tilt Type Check Valve Rubber Coated Disc - 500 Series	10
Tilt Type Check Valve Rubber Coated Disc - 500 PN25 Series	11*
Tilt Type Check Valve Rubber Coated Disc - U128 Series	12*
Tilt Type Check Valve Rubber Coated Disc - SC Series	13
Tilt Type Check Valve Metal Seated - SC-VAL Series	14~17*
Diaphragm Valve Weir (A) & Straight Thru (KB)	18~19*
ASG Series (Iron)	20~21*

* This version excludes some of these pages, refer to full version at website.



© Copyright Australian Pipeline Valve 1990 - 2024 Edition

Catalogues, photos, brochures and technical publications are the exclusive property of Australian Pipeline Valve. Any unauthorised reproduction in total or in part, shall result in prosecution. Products and data sheets in this publication are subject to change at anytime without notice. Australian Pipeline Valve reserves the right to carry out amendments to products and materials.

CHECK VALVE

CHECK VALVE (NON RETURN) TYPE APN

Cast Iron or rubber lined cast iron body, semi flexible disc swing check.
Design BS 5158, BSEN 12334.

RANGE OF APPLICATION

Size MM	Pressure Rating Bar	Hyd. test pressure in bar for	
		Body	Seat
15 - 350	7.0	10.5	7.7

Flanging

Connecting dimensions & thickness to ANSI(ASA)/BS/AS/EN/ISO specifications to suit ANSI B16.1, EN 1092-2, PN 6~16, AS 4087 PN 14~16, AS 2129 Table D to E, ISO 7005-1 PN 6~16, AS 4331.1 PN 6~16.

MATERIAL LIST

Part Name	Material
Body/End Piece	Cast Iron IS: 210Gr. FG. 260 with hard/soft rubber lining
Disc (or flap)	Steel reinforced plate rubber lined. Available in neoprene, viton, teflon etc.
Connecting bolts/nuts	Steel IS: 1367, Gr. 4.6/4
Valve Surface protection	Prime coat: chlorine-free with modified alkyd resin.
Linings Available	Food grade, halar, hard rubber, teflon etc.



FEATURES

Simple three parts design, with only one moving part. Disc 100% leak tight, 0.035 bar back pressure. Full bore design for minimum flow turbulence. Flap also serves as gasket seal between body and end piece. Valve usable in vertical or horizontal plane. Downtime is kept to a minimum as the flap can easily be replaced in minutes.

DIMENSIONS

Size (mm)	Size (inch)	Face to Face Dimensions A		Overall Dimensions B (mm)	Weight approx. kg.
		Unlined mm	Rubber Lined mm		
25	1"	144	150	124	4.0
40	1-1/2"	174	180	144	7.0
50	2"	194	200	166	8.5
65	2-1/2"	234	240	220	14.0
80	3"	254	260	220	20.0
100	4"	292	300	270	34.0
150	6"	392	400	322	56.0
200	8"	492	500	396	103.0
250	10"	590	600	500	190.0
300	12"	690	700	554	310.0

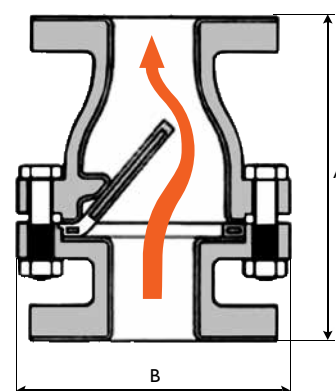

Rubber lining specification according to flow medium & working temperature.

Cast on flow direction arrow ensures correct installation.

When placing order, please specify flow medium, working pressure and working temperature.

Not recommended for use under vacuum pressure.

The catalogue is general in it's nature and design and can vary at any time. This catalogue is to be used as a guide only.

CHECK VALVE

CHECK VALVE (NON-RETURN) TYPE APNX

Cast Iron or rubber lined cast iron body, semi flexible disc, swing check.
Flow reversal of plus 0.35 bar. Design BS 5158, BSEN 12334.

RANGE OF APPLICATION

Size MM	Pressure Rating Bar	Hyd. test pressure in bar for	
		Body	Seat
25 - 350	7.0	10.5	7.7

Flanging

Connecting dimensions & thickness to ANSI(ASA)/BS/AS/EN/ISO specifications to suit ANSI B16.1 125LB, EN 1092-2, PN 6~16, AS 4087 PN 10~16, AS 2129 Table D to E, ISO 7005-1 PN 6~16, AS 4331.1 PN 6~16. EN 1092-2 PN 6~16.

MATERIAL LIST

Part Name	Material
Body/End Piece	Cast Iron IS: 210 Gr. FG. 260 with hard/soft rubber lining
Disc (or flap)	Steel reinforced plate rubber lined. Available in neoprene, viton, teflon etc. Grade "B" Butyl is standard.
Connecting bolts/nuts	Steel IS: 1367, Gr. 4.6/4
Valve Surface protection	Prime coat: chlorine-free with modified alkyd resin.
Linings Available	Food grade, halar, hard rubber, teflon etc.



FEATURES

Simple three parts design, with only one moving part. Disc 100% leak tight, 0.035 bar back pressure. Full bore design for minimum flow turbulence. Flap also serves as gasket seal between body and end piece. Valve usable in vertical or horizontal plane. Downtime is kept to a minimum as the flap can easily be replaced in minutes.

DIMENSIONS

Size (mm)	Size (in)	Face to Face Dimensions A		Overall Dimensions B mm	Weight approx. kg.
		Unlined mm	Rubber Lined mm		
25	1"	151	157	124	4.0
40	1-1/2"	180	186	149	7.0
50	2"	198	204	162	8.5
65	2-1/2"	238	244	216	14.0
80	3"	259	265	216	20.0
100	4"	348	356	295	34.0
150	6"	400	406	327	56.0
200	8"	492	500	396	103.0
250	10"	590	600	500	190.0
300	12"	690	700	554	310.0

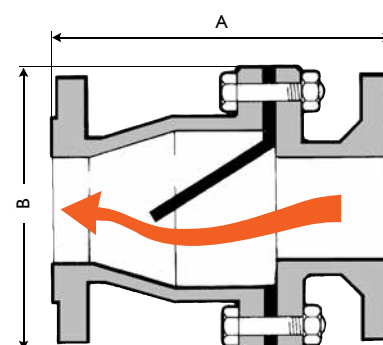

Rubber lining specification according to flow medium & working temperature.

Cast on flow direction arrow ensures correct installation.

When placing order, please specify flow medium, working pressure and working temperature.

Not recommended for use under vacuum pressure.

The catalogue is general in it's nature and design and can vary at any time. This catalogue is to be used as a guide only.

CHECK VALVES

BALL CHECK VALVE - BC SERIES

APPLICATION & CHARACTERISTICS

These full port ball checks with uninterrupted flow (equal to bore of pipe) are resistant to clogging and are ideal for wastewater, stormwater treatment, pumping dirty fluids. There is no accumulation of debris/deposits and the valve can be cleaned in-line without removal of entire valve and other neutral liquid applications. They can be used in horizontal & vertical service. BC series check valves have a low head loss and are self-cleaning due to the rotating ball.



Flanging

- ANSI B16.1 125lb, 150lb
- AS 4087 PN14, PN21
- AS 2129 Table D, E, F
- AS 4331.1 PN10, PN16, PN25
- EN 1092-2/ISO 7005-1 PN10, PN16, PN25

Face to Face Dimensions

- EN 558-1 Series 48 - was DIN 3202-F6 (Dimension L1)
- AS 4794 (Dimension L), AS 3579, ANSI B16.10

MATERIALS

No.	Qty.	Description	Material
1	1	Body	Ductile iron plus Epoxy Coat EN-GJS-400-15 DIN: GGG 40 ASTM: A536 65-45-12 BS: 1563 EN-JS 1030
2	1	Bonnet	Ductile iron plus Epoxy Coat EN-GJS-400-15 DIN: GGG 40 ASTM: A536 65-45-12 BS: 1563 EN-JS 1030
3	1	Ball	Nitrile or EPDM coated steel Polyurethane
4	2/4	Nut	Stainless steel
5	1	Gasket	Nitrile or EPDM
6	1	Degassing plug	Stainless steel Optional

Stainless body and PTFE/PFA/FEP coated ball available on request for chemical and high temperature applications.

DIMENSIONS

DN	L		H	ØD	ØK	n x ØM	Min. opening pressure (mbar)	Weight (kg)	
	mm	inch							
40	1 1/2"	180	200	113	150	110	4 x Ø19	6.9	6.32
50	2"	200	240	145	165	125	4 x Ø18.5	12.6	9.26
65	2 1/2"	230	260	169	185	145	4 x Ø18.5	20.5	15.1
80	3"	260	300	169	200	160	8 x Ø18.5	12.0	15.82
100	4"	330	350	211	220	180	8 x Ø18	16.0	24.46
125	5"	350	400	275	250	210	8 x Ø18	41.6	38
150	6"	410	500	294	285	240	8 x Ø22	25.7	48
200	8"	540	600	395	340	295	8 x Ø22	26.7	90
250	10"	640	700	482	400	350	12 x Ø22	32.5	145
300	12"	700	800	573	455	400	12 x Ø22	35.7	230
350	14"	800	900	654	505	460	16 x Ø23	54.2	336.7
400	16"	900	1000	781	565	515	16 x Ø26	64.0	482.9
500	20"	1100	1100	880	670	620	20 x Ø27	-	580
600	24"	1300	1300	1030	780	725	20 x Ø30	-	1080

STANDARDS

Manufacture according to the requirements of the European directive 97/23/CE (Equipment under pressure): category III modulate H. (DN 40-400)

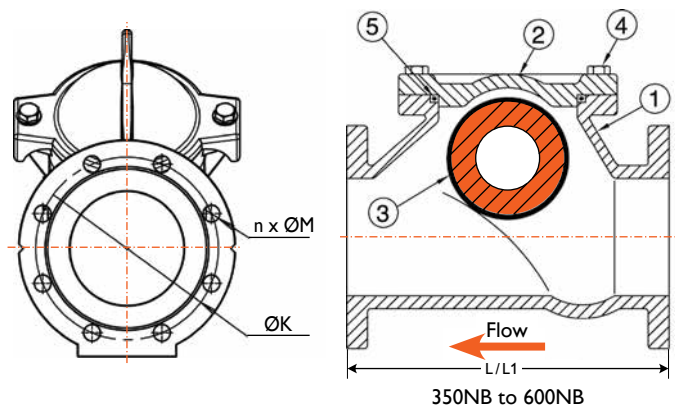
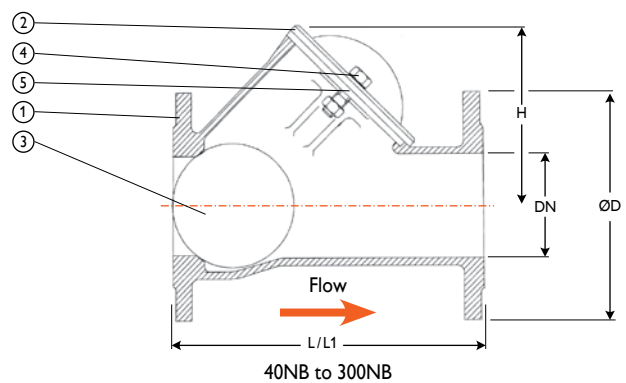
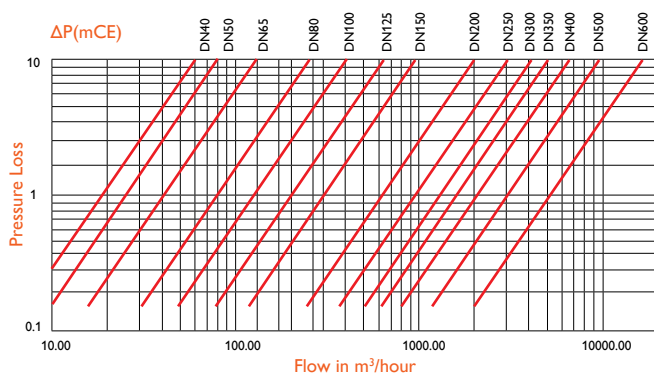

Balls used in Uniflo ball check valves are NBR or EPDM vulcanised with an iron, steel or aluminium core. PTFE/PFA coated ball also available.

Test Pressure

- Shell** - 26 bar before & after lining (Hydro.)
- Seat** - 16 bar after lining (Hydro.)
- Spark Test** - 100% Spark Test at 15 KVA for all lined parts in contact with fluid

SWING CHECK VALVE WITH LEVER & COUNTER-WEIGHT • SL404-CW

- Table D - SL404-D-CW**
- Table E - SL404-E-CW**
- PN10 - SL404-10-CW**
- PN14 - SL404-14-CW**
- PN16 - SL404-16-CW**
- PN21 - SL404-21-CW**
- PN25 - SL404-25-CW**
- 125 Class SL404-125-CW**
- 150 Class SL404-150-CW**
- 250 Class SL404-250-CW**

Design

BSEN 16767 (BS 5153), MSS-SP71 Type 1, ANSI B16.1

Flanging/Pressure Class

ANSI B16.1125lb, 150lb, 250lb

ANSI B16.42 150lb, 250lb

AS 2129 table D, E, F, H

AS 4087 PN10, PN14, PN16, PN21, PN35

ISO 7005-1, PN10, PN16, PN25

AS 4331.1 PN10, PN16, PN25

EN 1092-2 PN10, PN16, PN25

JIS B2220 5K, 10K, 16K, 20K

Face to Face Dimensions

ASME B16.10, EN 558-1, EN 558-2, EN 16767 (BS 5153)

(AS 4794 on request)

Test Standard

AS 4794, EN 12266-1, MSS-SP71, ISO 5208, API 598

MATERIAL LIST

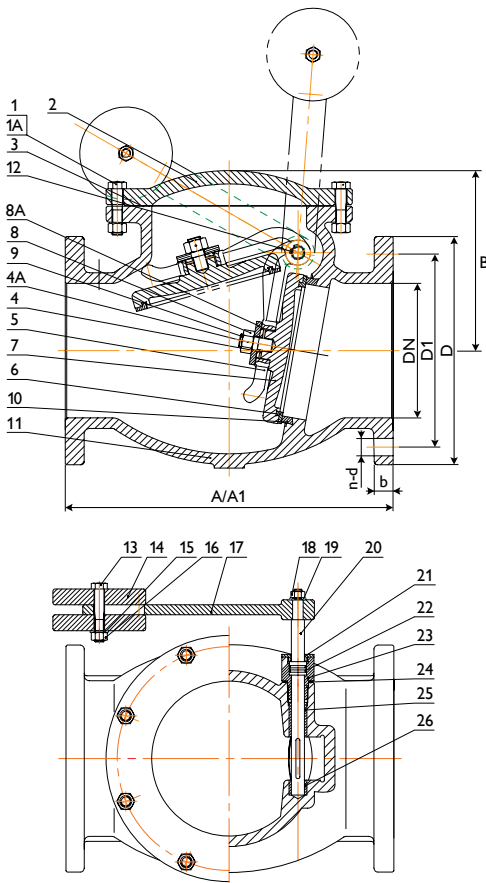

No.	Part Name	Material
1/1A	Cover Bolt & Nut	Steel
2	Cover*	ASTM A126 Class B
3	Gasket	Graphite / Teflon
4/4A	Hanger Pin & Split	304 or F6 Stainless Steel
5	Hanger	ASTM A536 Ductile Iron
6	Disc Ring	Bronze ASTM B62/F6/EPDM/NBR
7	Disc	ASTM A126 Class B
8/8A	Disc Washer & Nut	Steel
9	Disc Bolt	Steel
10	Seat Ring	Bronze ASTM B62 or F6 SS
11	Body*	ASTM A126 Class B
12	Retainer	Stainless Steel
13	Bolt	Steel
14	Balance Weight	Cast Iron
15	Washer	Steel
16	Nut	Steel
17	Connecting Lever	Ductile Cast Iron
18	Nut	Steel
19	Washer	Steel
20	Hanger Axle	Stainless Steel
21	Gland	Brass
22	O-Ring	EPDM/NBR
23	Stuffing Box	Brass
24	Washer	Teflon
25	Outside Bush	Brass
26	Inside Bush	Brass

* Ductile Iron Body for 250 Class and PN16 in larger sizes.

DIMENSIONS

MM

Class	Size (mm)	50	65	80	100	125	150	200	250	300	350	400	450	500	600
	Size (in)	2"	2.5"	3"	4"	5"	6"	8"	10"	12"	14"	16"	18"	20"	24"
125lb, 150lb Table D, Table E PN10, PN14, PN16	A	203	216	241	292	330	356	495	622	699	787	864	978	978	1295
	A1	287	295	318	356	400	494	533	640	711	-	914	914	1016	1219
	B	131	146	157	182	230	237	278	313	353	434	470	535	570	679
	D	152	178	190	228.6	254	279.4	343	406	483	535	597	635	700	815
PN21,PN25, PN35, 250lb Table F, Table H	D1	121	140	152.5	190.5	215.9	241.3	298.5	362	432	476	540	578	635	749
	A	267	292	318	356	400	445	533	622	711	-	-	-	-	-
	B	22.2	25.4	28.6	31.8	34.9	36.5	41.3	47.6	50.8	-	-	-	-	-
	D	165	191	210	254	279	318	381	445	521	-	-	-	-	-
	D1	127	149	168	200	235	270	330	387	451	-	-	-	-	-

Refer to drawing for other dimensions.

The catalogue is general in it's nature and design and can vary at any time. This catalogue is to be used as a guide only.

CHECK VALVE

TILT TYPE CHECK VALVE RUBBER COATED DISC 500 SERIES 125LB/PN10/PN16

Design

MSS-SP71, BSEN 16767 (BS 5153), BSEN 1074, ANSI B16.1/ANSI B16.42

Features

100% full flow area. Fusion Bonded Epoxy. Resilient lined body optional. Simple maintenance-free design, low headloss and non-slam characteristics. The valve's smooth, unrestricted full flow design makes it an excellent choice for slurries and sludge, even in vertical flow up applications.

Flanging/Pressure Class

ANSI B16.1 125lb, 150lb
ANSI B10.42 150lb, 250lb
AS 2129 Table D, E, F
AS 4087 PN14, PN16
ISO 7005-1, PN10, PN16
AS 4331.1 PN10, PN16
EN 1092-2 PN10, PN16
JIS B2220 5K, 10K, 16K, 20K

Face to Face Dimensions

ASME B16.10, EN 558-1, EN 16767 (BS 5153) (AS 4794 available)

Test Standard

AS 4794, EN 12266-1, MSS-SP71, ISO 5208, BSEN 1074

Pressure/Temperature Rating

Nitrile 16 bar from -10 to 100°C
EPDM 16 bar from -10 to 120°C
Viton 16 bar from -10 to 200°C

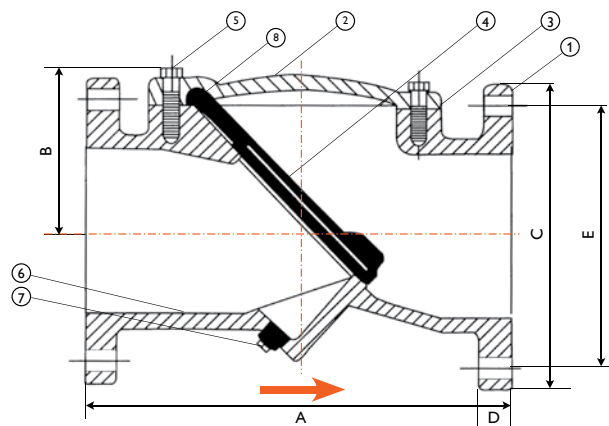

MATERIALS

No	Part	Material	Standard
1	Body	Cast Iron/Ductile Iron	ASTMA126 Class B Over 12" ASTM A53B-Gr65-45-12 Ductile Iron+FBE
2	Cover	Cast Iron/Ductile Iron	ASTMA126 Class B Over 12" ASTM A53B-Gr65-45-12 Ductile Iron+FBE
3	Gasket	Graphite or Butyl Rubber etc. on request	
4	Disc	Buna/EPDM/Viton/NBR	ASTM A-35/0-2000 encapsulated - & nylon reinforced butyl rubber
5	Bolt	Steel	AISI 1035/SAE Grade 5
6	Inner Coat	Epoxy or Lined	Epoxy or Chloro Butyl or Bromo Butyl etc
7	Plug	Malleable Iron	(Optional)
8	Hinge Pin	Stainless Steel	AISI 31655

* Body material is available in Ductile iron (14 inch and over is standard in ductile iron)

DIMENSIONS 125LB/150LB

Size (mm)	Size (in)	Model	A*		A1 (Lined)		B		C**		D		E**		
			(Unlined)	(Epoxy)	inch	mm	inch	mm	inch	mm	inch	mm	inch	mm	
50	2"	502	8	203	8-1/8	206.38	3-3/8	86	6	165	5/8	16	4-3/4	125	
65	2-1/2"	525	8-1/2	216	8-5/8	219.08	3-3/8	90	7	185	11/16	17	5-1/2	145	
80	3"	503	9-1/2	241	9-5/8	244.48	3-7/8	98	7-1/2	220	3/4	19	6	160	
100	4"	504	11-1/2	292	11-3/4	298	4-5/8	117	9	220	15/16	24	7-1/2	180	
125	5"	505	13-3/4	330	14	356	5-1/8	130	10	250	15/16	24	8-1/2	210	
150	6"	506	15	356	15-1/4	387	5-7/8	149	11	285	1	26	9-1/2	240	
200	8"	508	19-1/2	496	19-3/4	502		194	13-1/2	340	1-1/8	30	11-3/4	295	
250	10"	510	24-1/2	622	24-3/4	629	9-7/8	251	16	405	1-3/16	30	14-1/4	355	
300	12"	512	27-1/2	699	27-3/4	692	11-3/8	311	19	460	1-1/4	32	17	410	
350	14"	514	31	787	31-1/4	794	13-3/8	360	21	520	1-3/8	35	17-11/16	470	
400	16"	516	32	912	32-1/4	819	15-3/8	420	23-1/2	580	1-7/16	37	21-1/4	525	
450	18"	518	36	965	36-1/4	921	17-1/8	480	25	640	1-9/16	40	22-3/4	585	
500	20"	520	40	1067	40-1/4	1022	19-1/8	520	27-1/2	715	1-11/16	43	25	650	
600	24"	524	48	1219	48-1/4	1226	22-3/4	570	32	840	1-7/8	48	29-1/2	770	
750	30"	700	Refer to drawing for more information												

*Based on 500 Series, alternative face to face also available.

**Flanging as per AS/BSEN/ISO as required. Refer to drawing for Table D to F and PN10 to PN21.

CHECK VALVES

TILT CHECK VALVE RUBBER COATED DISC SC-SERIES



Application

Suitable for all types of water, air & steam 100°C.
(For higher temperature, consult us.)

Features

Sizes DN 50 ~ DN 600mm (2"~24")

Flanging

Flange Drilling to suit
ANSI B16.1, ANSI B16.5, BS EN 1092-2,
BS 10, AS 2129 D/E and AS 4087 PN 10/14/16.

Test Standard

MSS-SP71 Class 250 & EN 12334 PN16

Optional Accessories

Proximity Switch, Backflow Actuator,
Oil Dash-pot, Air Release Plug on the Cover.

OVERVIEW

The unique design of the hi-strength fabric reinforced rubber flapper disc creates an elastic spring to close-against the flow, combined with the tilted body seat (closing angle 35°) act to reduce the closing time, minimise the water hammer and flow reversal. Simplicity of design with three components (body, disc & cover) in one valve, and disc, hinge and pin are integral and fully encapsulated with special rubber for maintenance free, longlife, 1,000,000 continuous cycles tested with no sign of wear or distortion to the valve side and seat, body and cover are ductile iron. This valve will operate trouble free for a longer period compared to conventional check valves.

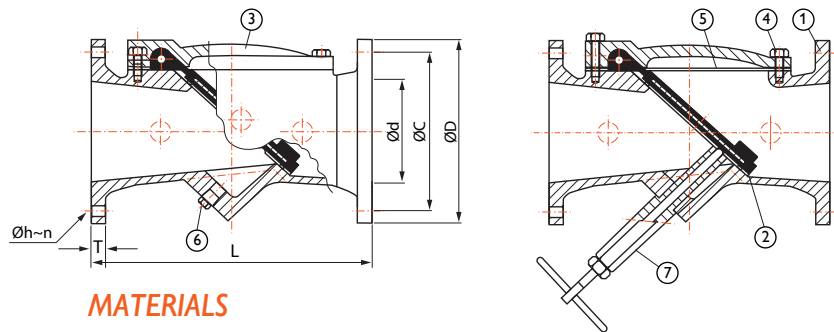

DIMENSIONS (MM)

SIZE Ød		L	ANSI B16.1 CL.125				
in	mm		ØD	ØC	Øh	n	T
2	50	203	152	121	19	4	16
3	80	241	191	152	19	4	19
4	100	292	229	191	19	8	24
6	150	381	279	241	22	8	25
8	200	495	343	299	22	8	29
10	250	622	406	362	25	12	30
12	300	699	483	432	25	12	32
14	350	787	533	476	29	12	35
16	400	813	597	540	29	16	37
18	450	965	635	578	32	16	40
20	500	1067	699	635	32	20	43
24	600	1219	813	749	35	20	48

MATERIALS

No	Parts	Material	ASTM Designation	BS SPEC
1	Body	Ductile Iron	A 536 Gr.65-45-12	EN 1563-EN-GJS-500-7
2	Disc	Steel & Rubber (Buna N)	A36 & D2000 AA7008	1506 & 2494
3	Cover	Ductile Iron	A 536 Gr.65-45-12	EN 1563-EN-GJS-500-7
4	Cover Bolt	Zinc Coated Steel	A 126 Class B	EN 1561-EN-GJL-250
5	Cover Gasket	Cast Iron	A 307 Grade B	4882
6	Plug	Malleable Iron	A 47	-
7	Backflow Actuator Assembly	-	-	-

HEAD LOSS CHART

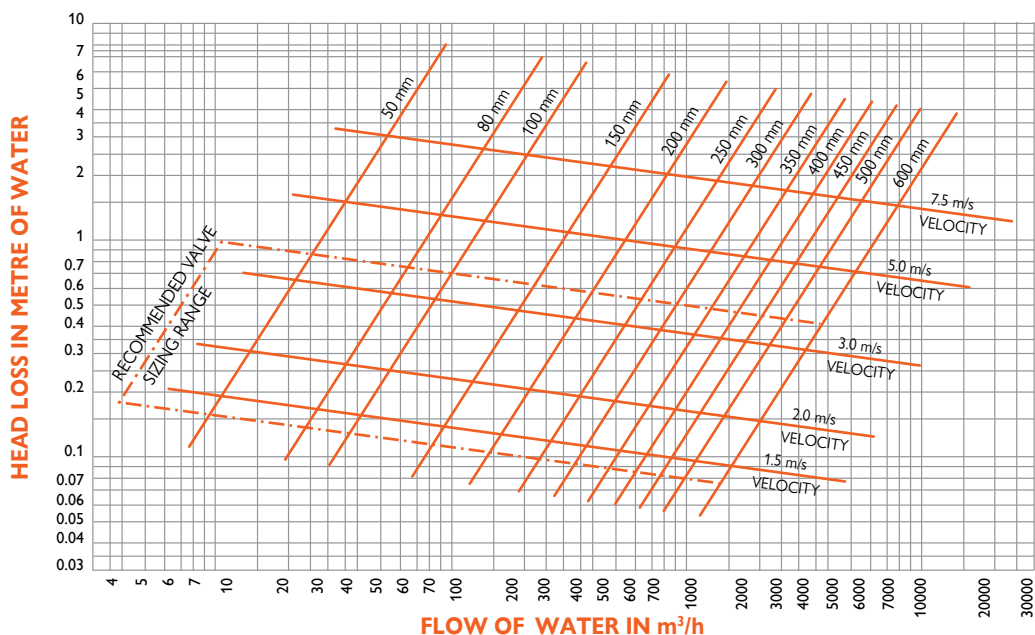

CHECK VALVE

TILTING DISC CHECK VALVE

500-SC-VAL PN10/16/25, 125~250LB



Uniflo Tilted Disc Check Valve provides energy efficient operation, while easily handling the most severe and demanding applications with features such as: non-slam closure, wear resistance, leak tight seating and versatility of operation.

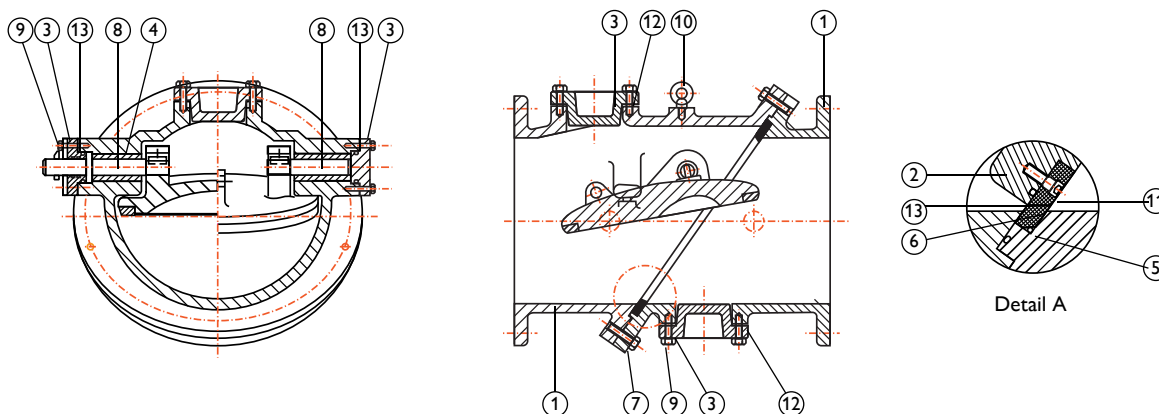

MATERIALS

No	Part	Materials	BS/EN Spec	ASTM Spec	TIS Spec
1	Body	Cast Iron	EN 1561-EN-GJS-250	A 126 Class B	TIS. 536
		Ductile Iron	EN 1563-EN- GJS-500-7	A 536 Grade 65-45-12	TIS. 537(SGI 500)
2	Disc	Cast Iron	EN 1561-EN-GJS-250	A 126 Class B	TIS. 536
		Ductile Iron	EN 1563-EN- GJS-500-7	A 536 Grade 65-45-12	TIS. 537(SGI 500)
3	End Plate	Cast Iron	EN 1561-EN-GJS-250	A 126 Class B	TIS. 536
		Ductile Iron	EN 1563-EN- GJS-500-7	A 536 Grade 65-45-12	TIS. 537(SGI 500)
4	Sleeve	Bronze/Gunmetal	EN1982-CC491 K	B62	-
5	Body Seat Ring	Bronze/Gunmetal	EN1982-CC491 K	B62	-
		Stainless Steel	Gr 1.4301,4401	A 276 Type 304,316	-
6	Disc Seat Ring	Bronze/Gunmetal	EN1982-CC491 K	B62	-
		Stainless Steel	(Optional)	A 276 Type 304,316	-
7	Body Bolt	Galvanised Steel	(Optional)	A 307 Grade B	TIS. 171
8	Hinge Pin	Stainless Steel	Gr 1.4301,4401,4057, 4021	A 276 Type 304, 316,431,420	-
9	End Plate Bolt	Galvanised Steel	4190	A 307 Grade B	TIS. 171
10	Eye Bolt	Galvanised Steel	4190	A 307 Grade B	TIS. 171
11	Socket Head Bolt	Stainless Steel	Gr 1.4301,4401	A 276 Type 304,316	TIS. 171
12	Gasket	Non Asbestos Sheet	-	-	-
13	O-Ring	Rubber (NBR)	EN 681-1	D 2000 CA 707	-
		Rubber (EPDM)	EN 681-1	D 2000 CA 707	-

* Body material is available in Ductile iron (14 inch and over is standard in ductile iron)



AUSTRALIAN PIPELINE VALVE®

COMPLETE PRODUCT LINE

“Australian Pipeline Valve produces isolation, control and flow reversal protection products for severe and critical service media in utility, steam, pipelines, oil & gas and process industries. APV valves and pipeline products form the most competitive portfolio in the market.”



SUPER-CHECK®



TORQTURN®

TWIN-LOK®

UNIFLO®



AUSTRALIAN PIPELINE VALVE BRAND RANGE - CATALOGUES

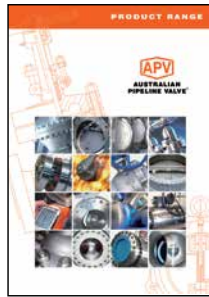

Product Brochure



Ball Valves Floating & Trunnion Mounted

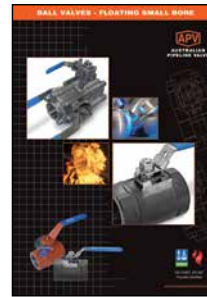

Ball Valves Floating Small Bore

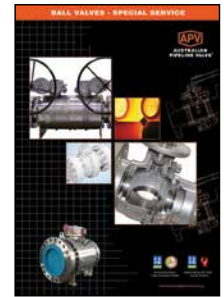

Ball Valves Special Service



Gate, Globe & Check Valves - Cast Steel



Gate, Globe & Check Valves - Forged Steel

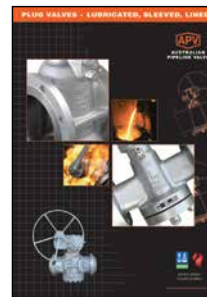

Plug Valves Lubricated, Sleeved & Lined

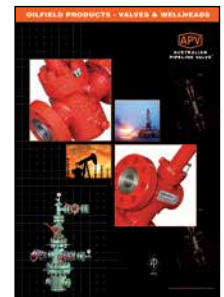

Oilfield Products - Valves & Wellheads

APV FAMILY OF BRANDS RANGE - CATALOGUES



Diamond Gear Gearboxes



Flowturn Ball Valves Multiway & Deadman



Flowturn Gate, Globe & Check Valves



Flowturn Instrument Valves

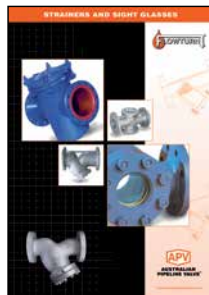

Flowturn Strainers & Sight Glasses



Steamco Steam Valves



Supercheck Wafer Check Valves



Superseal Butterfly Valves

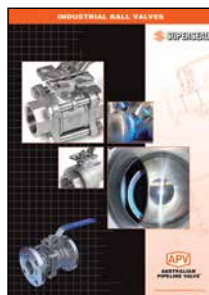

Superseal Industrial Ball Valves



Torqturn Actuators

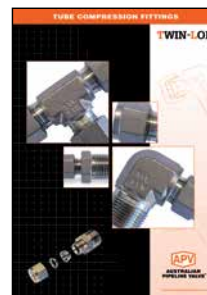

TwinLok Tube Fittings

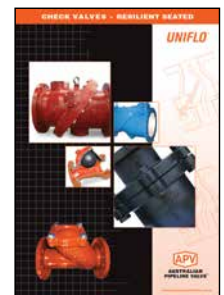

Uniflo Check Valves

Contact us for your local stockist/distributor



AUSTRALIAN PIPELINE VALVE®

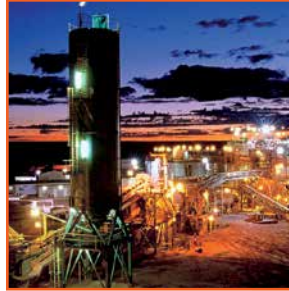

www.australianpipelinevalve.com.au

LOCAL DISTRIBUTOR



QUALITY ASSURANCE AND CERTIFICATION

We are continually improving all facets of quality assurance. Full metallurgical and test certificates are always supplied for all pressure retaining parts.

We have endeavoured to provide a broad outline of our range and capabilities. Because we are continually developing new products for our customers this catalogue will, to some extent be incomplete. This catalogue is a general overview only, individual drawings and data sheets can be furnished on request.

If you have any requirement in the field of valves, please contact us for a prompt response. Continuous development of Australian Pipeline Valve products may necessitate changes in the design or manufacturing processes. Australian Pipeline Valve reserves the right to effect any such changes without prior notice.

