

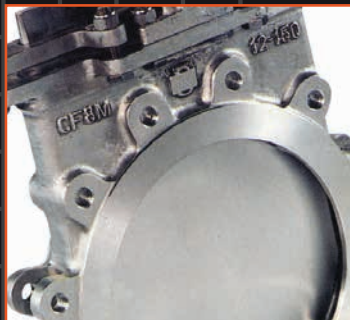

KNIFE GATE VALVES

DCNP-B SERIES
(Bi-Directional)



**AUSTRALIAN
PIPELINE VALVE®**



AUSTRALIAN PIPELINE VALVE®

COMPLETE PRODUCT LINE

“Australian Pipeline Valve produces isolation, control and flow reversal protection products for severe and critical service media in utility, steam, pipelines, oil & gas and process industries. APV valves and pipeline products form the most competitive portfolio in the market.”



AUSTRALIAN PIPELINE VALVE BRAND RANGE - CATALOGUES

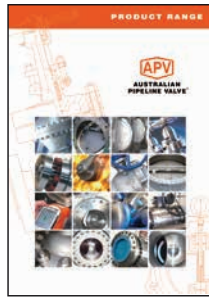

Product Brochure



Ball Valves Floating & Trunnion Mounted

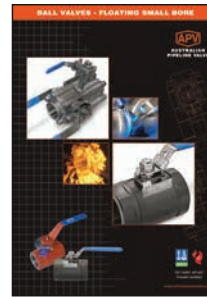

Ball Valves Floating Small Bore

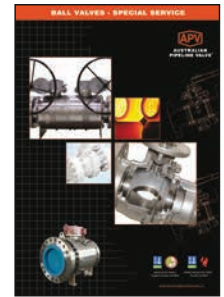

Ball Valves Special Service



Gate, Globe & Check Valves - Cast Steel



Gate, Globe & Check Valves - Forged Steel



Plug Valves Lubricated, Sleeved & Lined

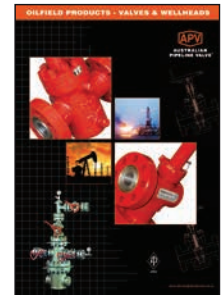

Oilfield Products Valves & Wellheads

APV FAMILY OF BRANDS RANGE - CATALOGUES



Diamond Gear Gearboxes



Flowturn Ball Valves Multiway & Deadman



Flowturn Gate, Globe & Check Valves



Flowturn Instrument Valves



Flowturn Strainers & Sight Glasses



Steamco Steam Valves

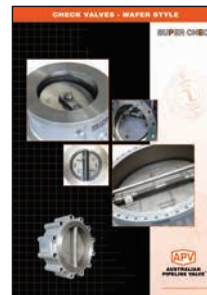

Supercheck Wafer Check Valves



Superseal Butterfly Valves

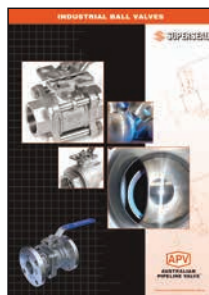

Superseal Industrial Ball Valves



Torqturn Actuators



Twin-Lok Tube Fittings



Uniflo Check Valves

Contact us for your local stockist/distributor

INDEX

Introduction	3
Overview	4
Safety Information	4-6
1.0 Installation	7-8
1.1 Preparation for installation	7
1.2 Installation instruction	7-8
1.3 Lifting valve	8-9
2.0 Handling & Installation	9-10
2.1 Assembly positions (horizontal pipe)	10
2.2 Assembly positions (vertical/leaning pipe)	10
3.0 Operation	10-12
4.0 Gear Operators	12
5.0 Leakage Across Seat	12
6.0 Disassembling Valves	13
7.0 Reassembly	13
8.0 Preventative Maintenance	13-14
9.0 Preventing Leakage Across Bonnet Gasket	14
9.1 Bonnet gasket replacement	14
10.0 Major Maintenance	15-17
10.1 Normal maintenance	15
10.2 Packing replacement	15-16
10.3 Seat replacement	16-17
10.4 Gate replacement	17

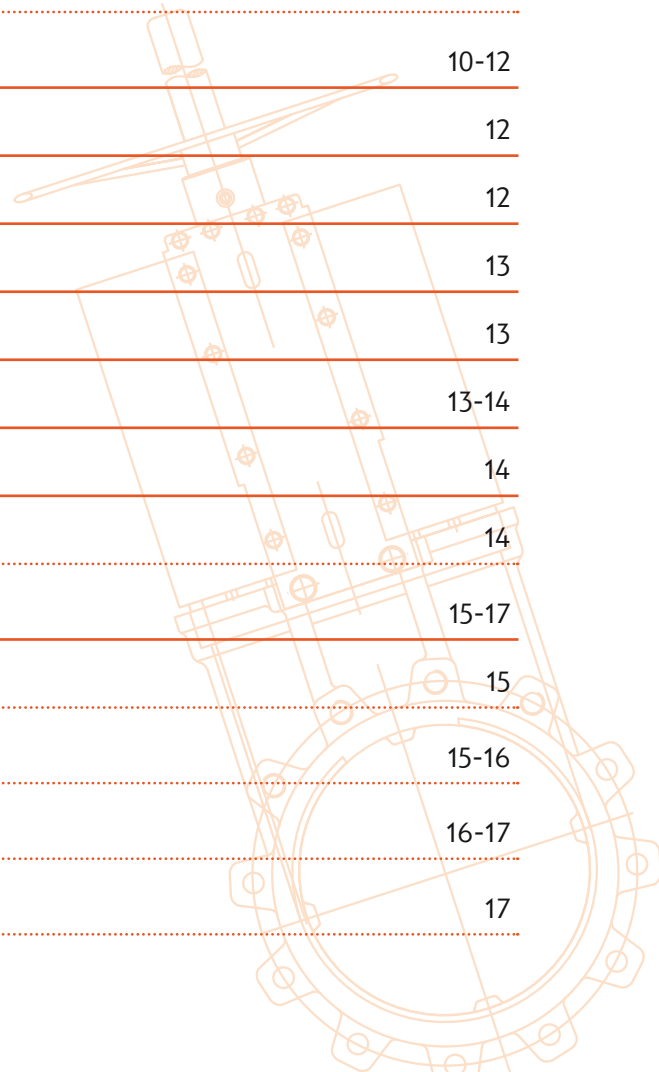

INDEX



11.0 Troubleshooting	18
Appendix A - Bolting torque sequence	19
Appendix B - Design DCNP-B Series	20
Appendix C - Bill of materials	21
Appendix D - Bill of materials - manual operated design	22
Appendix E - Bill of materials - double acting actuated design	23
Appendix F - Seat & cylinder selection	24
Warranty	25



© Copyright Australian Pipeline Valve 1990 - 2021 Edition

Catalogues, photos, brochures and technical publications are the exclusive property of Australian Pipeline Valve.

Any unauthorised reproduction in total or in part, shall result in prosecution. Products and data sheets in this publication are subject to change at anytime without notice. Australian Pipeline Valve reserves the right to carry out amendments to products and materials.

INTRODUCTION

The majority of this information is common knowledge to experienced valve users. When properly installed in applications for which they were designed, Flowturn valves will give long reliable service. This instruction is only a guide for installation and operation on standard service and covers general maintenance and minor repairs. A professional APV approved valve engineering facility should be utilised for reconditioning or major repairs.



Note

We do recommend however that this entire document be read prior to proceeding with any installation or repair. Australian Pipeline Valve and its parent company take no responsibility for damage or injury to people, property or equipment. It is the sole responsibility of the user to ensure only specially trained valve repair experts perform repairs under the supervision of a qualified supervisor.

RESPONSIBILITY FOR VALVE APPLICATION

The User is responsible for ordering the correct valves. The user is responsible for ensuring APV-Flowturn Valves are selected and installed in conformance with the current pressure rating and design temperature requirements. Prior to installation, the valves and nameplates should be checked for proper identification to ensure the valve is of the proper type, material and is of a suitable pressure class and temperature rating to satisfy the requirements of the service application.



Caution

Do not use valves in applications where either the pressure or temperature is higher than the allowable working values. Also valves should not be used in service media if not compatible with the valve material of construction, as this will cause chemical attacks, leakage, valve failure.

RECEIVING INSPECTION AND HANDLING

Valves should be inspected upon receipt to ensure:

- Conformance with all purchase order requirements.
- Correct type, pressure class, size, body and trim materials and end connections.
- Any damage caused during shipping and handling to end connections, hand wheel or stem.



Caution

The User is advised that specifying an incorrect valve for the application may result in injuries or property damage. Selecting the correct valve type, rating, material and connections, in conformance with the required performance requirements is important for proper application and is the sole responsibility of the user.

OVERVIEW

The Flowturn knife gate Series DCNP-B one-piece, cast body design offers rugged performance in application ranging from general purpose to severe media handling. Available with integral metal or replaceable soft seat, the Flowturn knife gate Series DCNP-B valve is easily automated for on/off applications. DCNP-B gate valves are not suitable for Air & Gas or any highly erosive or corrosive or hazardous service. They are also not suitable for low or high temperature service outside of the range shown on our as-built drawings. Resilient seat valves are only suitable for clean liquid service and liquid service with a small amounts of particulates or impurities. Any abrasive particles will shorten the life of the resilient seat. PTFE seat potentially provides a longer life than elastomer. The chemical compatibility and temperature limitations of the seat and bonnet seal materials must be considered by the purchaser prior to purchase.

Valve features include:

- Top works designed for easy, quick conversion between manual and pneumatic actuation. Manual valves include a lubricant injection port for continuous, smooth operation with minimal maintenance.
- Clevis design and horizontal bolting stabilises gate ensuring proper alignment.
- Energised quad seal packing for enhanced gland sealing.
- Standard integral metal seat and optional replaceable resilient seats.
- Gate design ensures consistent alignment throughout the length of the stroke.
- Body design with no dead pockets.

SAFETY INFORMATION

The following general safety information should be taken in account in addition to the specific warnings and cautions specified in this manual. They are recommended precautions that must be understood and applied during operation and maintenance of the equipment covered in this I.O.M.



Caution

To avoid injury, never attempt disassembly while there are pressures either upstream or downstream. Even when replacing stem packing, caution is necessary to avoid possible injury.



Caution

To prevent valve bending, damage, inefficient operation, or early maintenance problems, support piping on each side of the valve.

In order to avoid personal injury and other types of damage (to property, the plant, etc.), we recommend following these recommendations:

- The personnel responsible for handling and maintenance of the equipment must be qualified and trained in operations with this type of equipment.
- Use appropriate personal protection (gloves, safety boots, goggles, helmet, high-visibility vest...).
- Shut off all operating lines to the valve and put up a warning sign.
- Completely isolate the valve from the whole process.
- Depressurise the process.
- Drain all the line fluid through the valve.
- Use hand tools not electric tools during installation and maintenance.

Before installation, inspect the valve body and components for any possible damage occurred during transport or storage. Make sure that the valve's inside cavities are clean. Inspect the pipes and the flanges to make sure they contain no foreign material and are clean.



Caution

- *A valve is a pressurised mechanism containing energised fluids under pressure and consequently should be handled with appropriate care.*
- *Valve surface temperature may be dangerously too hot or too cold for skin contact.*
- *Upon disassembly, attention should be paid to the possibility of releasing dangerous and or ignitable accumulated fluids.*
- *Ensure adequate ventilation is available for service.*

This manual provides instructions for storing, general servicing, installation and removal of gate and globe valves.

APV and its re sellers refuse any liability for damage to people, property or plant as well as loss of production and loss of income under any circumstances but especially if caused by: Incorrect installation or utilisation of the valve or if the valve installed is not fit for intended purpose. It is the sole responsibility of the user to ensure the valve type and materials are correctly specified.

DURING OPERATION TAKE INTO ACCOUNT THE FOLLOWING WARNINGS:

- a- Graphite/Graphoil packing and body gaskets are very brittle, any impacting, twisting or bending should be avoided.
- b- The valve's internal parts such as disc, stem, seats, seals, gaskets shall be handled with care avoiding scratches or surface damage.
- c- All tools and equipment for handling the internal parts shall be soft coated.
- d- Valves can be fitted with gaskets or seals in PTFE, Buna, EPDM, NBR, Viton, etc., Hence chemicals or high temperatures will damage sealing components and cause seat and bonnet leakage.
- e- Never part open valve or part close, gate valves must be full open or full closed to avoid seat damage. Globe valves can be used to throttle (on clean service only) for short periods but must be at least 25% open or else venturi action will damage seating area and body.

For all operations make reference to position number on part list of the applicable drawing listed.



Caution

Packing leakage could result in personal injury. Valve packing is tightened prior to shipping but may require readjustments to meet specific service conditions. Check the temperature and chemical compatibility of bonnet and seat seals. Never use a DCNP-B knife-gate for flammable or hazardous liquids or gases. A special bonneted valve with more complex seating design is required for such service.



Caution

Personal injury may result from sudden release of any process pressure. APV recommends the use of protective clothing, gloves and eye wear when performing any installation or maintenance. Isolate the valve from the system and relieve pressure prior to performing maintenance. Disconnect any operating line providing air pressure, control signals or electrical power to actuators.



Caution

Check the packing box for pressurised process fluids even after the valve has been removed from the pipeline, particularly when removing packing hardware or packing rings, or removing packing box pipe plug if fitted.



Caution

If a gasket seal is disturbed while removing or adjusting gasketed parts, APV recommends installing a new gasket while reassembling. A proper seal is required to ensure optimum operation.

1.0 INSTALLATION



Caution

Piping should be properly aligned and supported to reduce mechanical loading on the end connections.

The valve must always be installed in the OPEN position.



Caution

Verify line is depressurised before installing, removing or repairing a valve or operator.

Do not pressurise the line without an operator on the valve.

The device generates a large mechanical force during normal operation.

Observe all applicable safety regulations for valves installed in potentially explosive (hazardous) locations.

1.1 PREPARATION FOR INSTALLATION

1. Remove protective end caps or plugs and inspect valve ends for damage to flange faces.
2. Thoroughly clean adjacent piping system to remove any foreign material that could cause damage to seating surfaces during valve operation.
3. Verify that the space available for installation is adequate to allow the valve to be installed and to be operated.



Note

Ensure sufficient clearance for the stem in the full open position. Inadequate clearance for valves may add mechanical loading to the valve ends. Sufficient clearance should be allowed for threaded end valves to be 'swung' during installation.

1.2 INSTALLATION INSTRUCTION

DCNP-B gate valves are Bi-directional.

Gate valves should be installed with the stem in a vertical up position on horizontal lines. Never install with the stem below the horizontal axis, as complete drainage is not possible and solids may accumulate in the valve gland to gate area, which will greatly affect the valve operation and service life. If valves are to be installed in vertical lines, please specify at time of order as this is non standard. Refer section 2.0 for more information on orientation.

Reliable support is required for valves with larger diameter (size over DN250), heavy actuator or uncommon positions.

It is good practice to provide additional support for all pneumatically, hydraulic and electric actuated valves installed in the horizontal stem position. This includes ALL valve sizes due to the fact that many of these installations are located in high vibration areas. Failure to provide additional support will result in premature valve failure.

1. Special care should be taken to maintain the correct distance between the flanges and to ensure that they are parallel to valve body. Incorrect alignment of valve will cause deformations, which can lead to difficulties in operation.
2. Install 2-3 studs on the body button loosely.
3. Insert the appropriate gaskets between valve and pipe flanges. The materials of the gasket is up to the customers selection. Customer can also consult our technicians for suggestions.
4. Place studs in balance positions and tighten evenly in a cross over pattern. Care should be taken when the body drilling cavity studs are tightened to ensure no damage to the valve body. See Appendix A for bolt tightening sequence.

1.3 LIFTING VALVE

Refers to Figures 1 to 8 below on lifting methods for horizontal and vertical lifting.

Do not lift the valve or hold it by the actuator. Lifting the valve by the actuator can lead to operating problems as it is not designed to withstand the valve's weight.

Do not lift the valve or hold it by the flow passage area. The valve's seal is located in this area. If the valve is held and lifted by this area it can damage the surface and the O-ring seal and lead to leakage problems whilst the valve is operating.

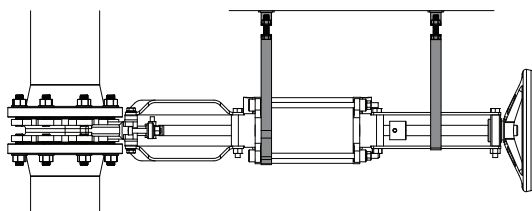

FIGURE 1

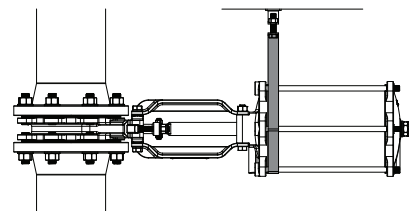

FIGURE 2

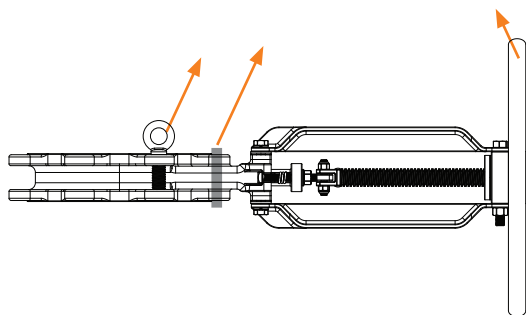

FIGURE 3

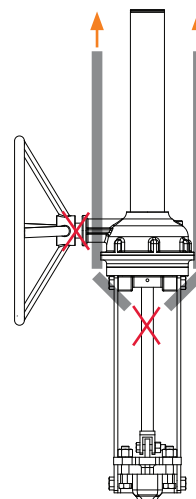

FIGURE 4

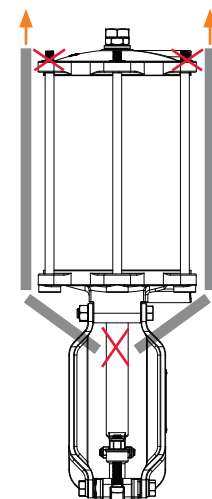
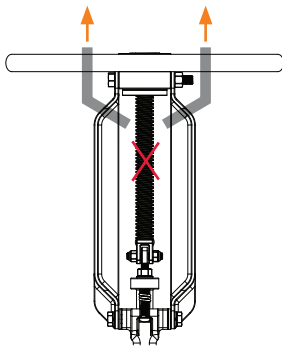
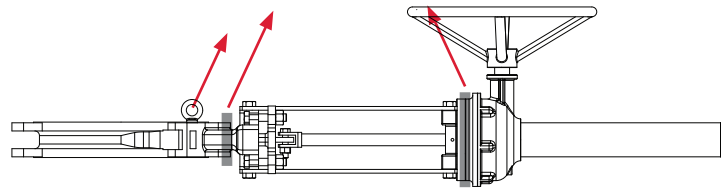
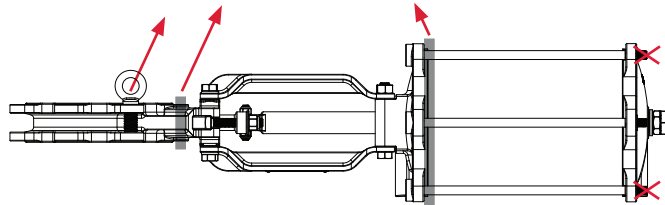

FIGURE 5

FIGURE 6

FIGURE 7

FIGURE 8

2.0 HANDLING & INSTALLATION

1. Take care in handling valves especially the sealing faces.
2. Make sure that piping and equipment is clean of dust, rust and pipeline scale. Clean all adjoining pipe and fittings. Remove end protector covers from the valves immediately prior to installation. Blow compressed air inside the valves to remove residual dust, dirt, etc., from inside the valves as this could hamper the valves functioning and could also damage the seats.
3. Make joints tight but do not overstress them. This is very important when your tightening gland packing nuts. Always tighten in a diagonal pattern, gradually increasing torque settings.
4. Install valves in the connecting piping so that the arrow mark on the valve body coincides with the flow direction in the pipe.
5. Once the valve has been installed, check that all the screws and nuts have been correctly tightened and that the whole valve action system has been correctly adjusted.
6. Even if the valve has been assembled and tested at APV's facilities, the screws on the stuffing box may come loose during handling and transport and must be re-tightened.
7. After installation it is advisable to once again flush the piping. Check carefully for visible leaks if any and tighten stem packing and/or bonnet nuts accordingly.
8. If the leakage still persists change the bonnet gasket. Ensure suitable gasket material, we recommend a PTFE bonnet gasket.
9. Flowturn DCNP-B knife gate valves may be installed in a vertical or horizontal pipeline; however the normal method is directly upright relative to the pipeline. Other positions (but ideally no more than 30 degrees from upright) are acceptable; however they may result in uneven valve wear. Above 300NB (12") other positions are not recommended.
10. The DCNP-B valve is bi-directional.

2.1 ASSEMBLY POSITIONS (HORIZONTAL PIPE)

The valves can be assembled in all positions - however see Figure 9 and 10, for recommendations for some of them.

Position 1: This is the most advisable position.

Positions 2 and 3: For standard valves larger than DN150 and maximum installation angle permitted with vertical of 30°.

Positions 4 and 5: For valves larger than DN250, please contact APV. For sizes smaller than DN300 the valves can be installed on an angle of up to 90 degrees in these positions but reduced life may be experienced. It must be stated prior to manufacture.

Positions 6, 7 & 8: Debris accumulation will affect sealing and shorten valve life. To install valves larger than DN150 in any of these positions, please check with APV. It must be stated at time of order prior to manufacture but it is not recommended. In all these positions it is recommended to secure the actuator to prevent the shaft from bending due to the weight of the actuator. If this is not taken into account, it can lead to problems during valve operation.

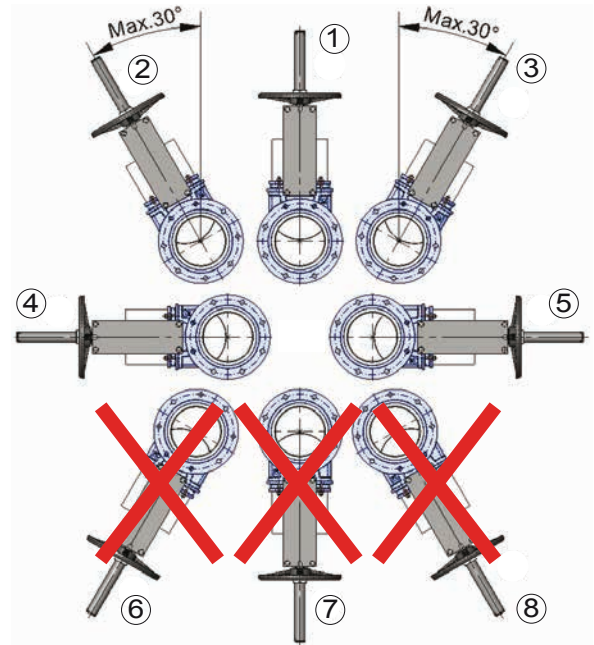

FIGURE 9

2.2 ASSEMBLY POSITIONS (VERTICAL/LEANING PIPE)

The valves can be assembled in all positions; however, recommendations do exist for some of them, see Figure 10.

Positions 1 & 2: In these positions it is recommended to secure the actuator as its weight can cause the shaft to bend.

If this is not taken into account, it can lead to problems during operation. Even then it is only suitable for clean fluid service up to 300NB and manual operation only.

Position 3: Not recommended - special order.

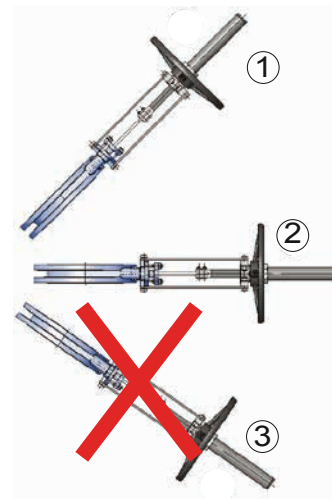

FIGURE 10

3.0 OPERATION

1. Check visibly for any leaks and re-tighten the joints/glands.
2. Manually operated valves are to be operated through handwheel. To open the valve, turn the handwheel anti-clockwise. To close the valve, turn the handwheel in clockwise direction.
3. Turn the handwheel slowly initially so as to prevent undue stress on the valves due to thermal gradient, water hammering, etc.

4. Never use too much force for either closing or opening the valve, never attempt to apply leverage with a long lever as this could damage yoke nut.
5. Operate the valve with no flow in the pipeline for one cycle to make sure smooth operation.
6. Then test operation and valve seal with flow. When the pressure is increasing gradually to full pressure, there might be minor leakage at packing result from shipping and storage. This can be remedied by tightening the gland follower. The nuts should be tightened gradually and crosswise until the leakage stops.
7. Operate the valve under full pressure for one cycle to test the seal and actuator.
8. If no problem occurs, valve is good for on-off processing.



Note

Knife gate valves are not designed for flow throttling, as this will lead to gate damage.

9. RESILIENT SEATED VALVES – All resilient seated knife gate valves require the resilient seat to be lubricated before stroking, regardless of the type of actuator. The fit pressure of the gate against the resilient seat, on the sides of the valve up through the packing gland, is such that stroking the valve dry, that is with no lubrication of any kind, will cause the resilient seat to cold flow beyond safe limits and will damage the seat with just a few strokes. CRC 6-56™ or WD-40® (Note: Make sure the lubricant used is compatible with the seat material and process media), sprayed on the seat, up in the chest area, on both sides, will normally provide sufficient lubrication. This should be repeated every 2 or 3 strokes. This is CRITICAL to the life and performance of the seat. In operation, the process product normally supplies adequate lubrication.
10. VALVES WITH OPTIONAL STOPPERS (LOCK CAPS) – After installing resilient seated valves with stoppers, be sure to determine that the stopper and stopper nut are set properly.
 - a. Remove the stopper nut and stopper.
 - b. Turn the hand wheel in a clockwise motion until the gate bottoms out.
 - c. For resilient seated valves, turn the hand wheel an additional 1/4 turn, and then go to step “f”.
 - d. Turn the hand wheel an additional 1/2 turn counterclockwise.
 - e. Now freely spin the hand wheel clockwise once, until it stops on its own.
 - f. Return the stopper and run it down until it meets the wheel nut.
 - g. Return the stopper nut and run it down tight against the stopper to hold it in position.
11. After the valve has been installed, cycle the valve once completely. Open the valve by turning the hand wheel counter clockwise, reverse the operation for closing. (Note: This will detect if any damage has been incurred due to either shipping or installation processes.) After cycling the gate valve, turn the hand wheel counterclockwise several turns allowing partial opening for preparation to fill system.

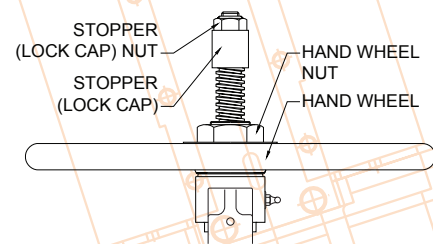

FIGURE 11

12. Open upstream valve slowly, building system pressure gradually, allowing installation personnel to detect any excessive packing gland leakage, making adjustments necessary.
13. After the system has come to full pressure, open the knife gate valve fully by turning the hand wheel counterclockwise, then close the valve fully by turning the hand wheel clockwise. In resilient seated knife gate valves, this process will result in “seating in the valve”. This step may be eliminated with the metal seated valve.
14. You may now use the valve for its intended purpose, keeping in mind that a knife gate valve should be used in a full open or full closed position. Knife gate valves should not be used for throttling service unless specifically configured for such use.

4.0 GEAR OPERATORS

The gear operator is lubricated with grease (2% MOS2) for life.

Only in case of failure of any components remove the upper gear casing from lower gear casing. After inspection replace the necessary components.

1. When repairing the drive sleeve and bearing (thrust ball bearing) there should not be any clearance, i.e. the drive should not move axially.
2. Proper installation will correct operation.



Caution

Do not dismantle the upper and lower gear casing as it will disturb the whole assembly and the deep groove ball bearings, the operator provided is properly lubricated for long life.

5.0 LEAKAGE ACROSS SEAT

It is always difficult to ascertain whether there is an internal seat leakage unless there is pressure or leak detection facility in place to monitor any rise or fall in pressure or leakage.

To investigate suspected leakage, the valve should be removed from the line then dismantled. Prior to removal from line ensure all pressure and fluid is purged from line and valve cavity. Remove disc and inspect the seating surfaces, also inspect the body seat for any sign or wire drawing/light scratches.

Relap or replace the seats or gate as required if minor damage or else send the valve to an experienced APV approved valve repair facility. Assemble the valve, should any leaks still persist then the concerned part may need complete replacement.

When ordering spare parts for replacements, kindly inform us the size, type, rating, part description, model number and serial number.

6.0 DISASSEMBLING VALVES

1. Check that the line is in a complete shut down phase.
2. Pre-order all necessary spare gland packings and jointing gaskets.
3. Open the valve slightly by turning the handwheel anti-clockwise and loosen the gland.
4. Remove any process product observing all safety precautions.
5. Put identification markings on valve body, bonnet, disc/gate, yoke, and actuator. This helps to avoid mismatching of parts at the time of re-assembly.
6. If the bolts and nuts are too tight, apply deep penetrating oil and then unscrew.

Also refer to section 10.0 for detailed instructions.

7.0 REASSEMBLY

1. Re-assemble in reverse order of disassembly.
2. For larger valves, lift up the bonnet using lifting lugs where provided. For smaller valves, gently and evenly break the bonnet seat with a lever (if required) before lifting the bonnet off (where required use with a sling mechanical lifting device). Clean gasket surface areas, replace gasket and refit bonnet.
3. Refer Appendix A for bonnet bolt re-tightening procedure.
4. Before installation do inspection on valve;
 - a) Make sure the valve body and components are in good condition.
 - b) Make sure internal cavities of valve body are clean.
 - c) Make sure corresponding flange and pipe line are free of foreign material.

Also refer to section 10.0 for detailed instructions.

8.0 PREVENTATIVE MAINTENANCE

1. Inspect whether all valves can be opened or closed smoothly at least once a month. If the operation is sluggish, clean the spindle threads and lubricate the same.
2. Check the gland tightening nuts for any leaks or slackness, if required tighten these nuts and ensure that the valve operation is not hampered by over tightening the gland.
3. The manual valve stem should be lubricated at regular intervals with industrial grease for smooth operation of the valve. A lubrication nipple is provided on the collar.

Note, use genuine APV new gland packing sets when replacing.



Caution

Do not attempt to repack the stem packing in line while the valve is under pressure. The line must be totally purged. Knife Gate valves do not all have the 'back seating' feature. Prior to removing bonnet, exercise extreme caution no pressure is trapped in the valve cavity. Wear appropriate safety apparel and follow industry and plant safety procedures.

9.0 LEAKAGE ACROSS GASKET

Should any body gasket leaks occur, tighten the bolts/nuts & studs (refer Diagram 1, Appendix A). If leakage still persists, the bonnet gasket should be changed.

9.1 BONNET GASKET REPLACEMENT

- a. Carefully clean the stuffing box. If oil, grease, or graphite impregnated packings were used, it may be necessary to use a solvent to clean the stuffing box.
- b. Use precut packing kits, purchased from Flowturn, or carefully cut each ring by wrapping a length of packing around the blade snugly, but without tension. With packing snips, cut each ring individually, making 450 cuts at the butting ends.
- c. If the valve was supplied with a gate scraper(s), install it into the stuffing box first making sure the scraper is centered around the blade (this will require unbolting of the stem clevis). Then insert the packing rings one at a time. Tamp each ring lightly in place using a flat packing iron. Successive layers are installed in the same manner. Alternate packing joints at 90° or 180° with each layer to minimize leakage as shown in illustration.
- d. It may be necessary to compact the lower packing to get all rows installed. If so, pull the packing gland down and tighten using the two end studs until the packing gland almost bottoms out.
- e. Remove the packing gland again as previously described.
- f. Continue inserting packing as described above.
- g. Pull down the packing gland over the gland studs. Using lock washers and nuts, tighten the packing gland using the cross-over method. **DO NOT OVER TIGHTEN.**
- h. Bring the valve up to pressure and tighten the packing gland following the procedures listed in the maintenance section.

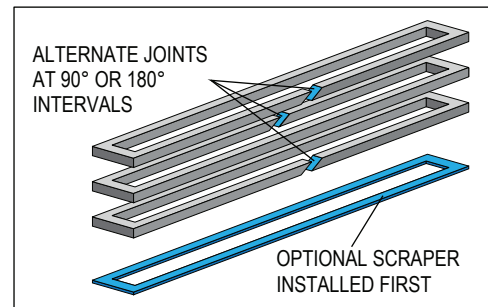

10.0 MAJOR MAINTENANCE

Only an expert APV approved valve re-conditioner should attempt the following major extraordinary maintenance/repairs. Valve parts are subject to normal wear and must be inspected and replaced as necessary. Inspection and maintenance frequency depends on the severity of the service conditions. This section includes instructions for packing adjustments, repacking, seat replacement and seating adjustment.



Caution

To avoid personal injury to yourself, fellow workers, or damage to property from release of process fluids, before performing any maintenance:

- Shut off all operating lines to the valve.
- Isolate the valve completely from the process.
- Release process pressure.
- Drain the process fluid from the valve.

10.1 NORMAL MAINTENANCE

Normal maintenance of Flowturn knife gate valves may only include a periodic tightening of the packing gland. Should a leak occur at the packing gland, simply tighten the packing gland bolt closest to the leak. This may require tightening two or three bolts on larger valves. After the leak has stopped, tighten all packing gland bolts 1/4 turn. Do not over tighten. The only other normal maintenance required would be to grease the valve stem, by using a grease gun at the grease fitting located on the valve yoke.

1. Grease the valve stem periodically. Rotate the stem protector counter clockwise to take it off. Apply grease to the stem and cycle the valve once.
2. There would be minor leakage at the packing after long term operation. This can be solved by tightening the bolts on gland follower in crosswise pattern.

10.2 PACKING REPLACEMENT



Caution

First remove the valve from the line. To prevent injury ensure that all fluid and pressure is removed from the valve both upstream and downstream before removal and disassembly. When removing drain or stem plug wear protective eye masks to avoid injury.

Refer to Appendix C for exploded bill of materials.

1. Depressurise the circuit and place the valve in closed position.
2. Remove the gate guards.
3. Release stem from the gate.

4. Loosen screws at the bottom of the yoke, and take off actuator of handwheel with yoke connected on.
5. Remove old packing and clean the packing cavity.
6. Insert new packing and tighten the gland follower steadily.
7. Place yoke (with actuator or handwheel mounted on) and screw it on the valve.
8. Connect stem to gate.
9. Mount gate guards.
10. Perform several operation cycles with loaded pipeline and adjust the gland followers to ensure no leakage.



Caution

The stem packing system will vary according to valve size, type and class as well as the stem packing material specified.

10.3 SEAT REPLACEMENT

1. Remove valve from pipeline.
2. Take seat retainer off.
3. Remove the old seat and clean the cavity.
4. Insert the new seat.
5. Perform several operation cycles with loaded pipeline to make sure the seal is tight.
6. **DETAIL OF SEAT REPLACEMENT PROCEDURE**
 - a. Disassemble the entire valve and remove old packing as described above.
 - b. Remove the old seat and clean seat body cavity with a wire brush and a solvent, making sure the entire cavity is clean of foreign matter.
 - c. Place the new seat on the top of the valve body, centering it on the valve per figure 12.

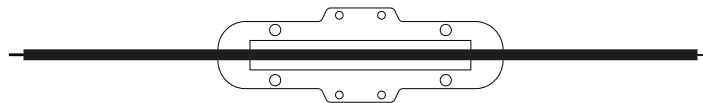

FIGURE 12

- d. Take hold of the ends of the seat material and, with equal pressure, push the new seat into the body cavity. This action should produce a “U” shaped form as the seat slides into the valve cavity.
- e. Push the seat down until it reaches the bottom of the valve, keeping both ends of the seat extending equally from the top of the valve as shown in figure 13.
- f. Using a flat blade screwdriver, gently work each side of the seat under the retaining lip in the bottom of the valve. It may be necessary to gently tap the seat with a rubber mallet as the seat is worked into body.

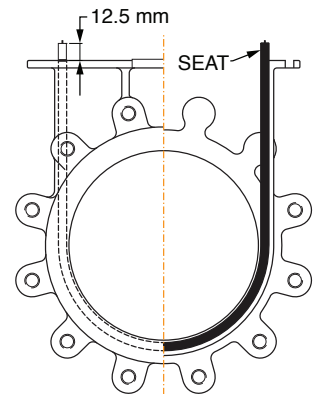

FIGURE 13

- g. Once the seat is positioned as in figure 14, use a blunt piece of wood or plastic to gently tap the seat to the bottom of the seat trough.
- h. Trim the remaining material at the top of the valve body approximately 12.5 mm above the mounting flange per figure 13.
- i. Lubricate the exposed seat surfaces with Syl-Glyde® (NAPA p/n 765-1351 or equivalent) or light grade oil.
- j. Insert valve gate into the body, keeping the gate centred in the cavity as it is installed. Push firmly or lightly tap with a rubber mallet until it reaches the bottom of the valve. The gate should be in contact with the seat along the entire edge of the gate.
- k. Repack valve following the repacking procedures previously outlined.
- l. Reinstall packing follower and tighten the bolts equally starting at the centre and working to the ends.
- m. Reinstall the yoke assembly while making sure the valve operates freely and the gate is properly seating to the seat material.

FIGURE 14

10.4 GATE REPLACEMENT

1. Perform step 1. to step 5. of packing replacement as shown above in 10.2.
2. Remove seat and gate guide points (right above the valve inlet port).
3. Remove the old gate.
4. Clean body cavity and insert new gate in carefully (no impact with the valve cavity).
5. Re-install the seat.
6. Perform step 6. to 10. of packing replacement as shown above in 10.2.
7. After assembly, re-tighten gate scraper guides.

Do not over tighten bolts. Hydrostatically test the valve to ensure that there is no leakage. Refer to Diagram 1, Appendix A for bolt tightening sequence.

Caution

Always be sure that the valve is de-pressurised and isolated prior to performing any maintenance work. Do not attempt to repair valve in-line if volatile, dangerous, hazardous or flammable service. Always wear fully enclosed, splash proof, protective eye wear.

11.0 TROUBLESHOOTING

TROUBLE	POSSIBLE CAUSE	SOLUTION
Packing Leakage	<ul style="list-style-type: none"> > Incompatible media > Packing deterioration > Temperature variation > Normal packing wear 	Replace packing
Soft Seated Valve: In fully close position, seat leakage	Seat is worn or damaged	<ul style="list-style-type: none"> a) Remove worn or damaged seat b) Inspect and clean seat chamber, install new seat c) Replace bonnet/stem packing
	Gate is damaged	Replace gate
High torque during valve seating and unseating	Entrapped foreign media in pipeline prohibiting valve from seating	Consult factory for proper solutions
	Gate scraper guides too tight	
	Packing not tighten to recommended torque	<ul style="list-style-type: none"> a) Remove valve from service b) Review gate to seat interface
Unable to close or open gate	Solidified media between body and gate	<ul style="list-style-type: none"> a) Check for valve orientation b) Re-orient valve c) Replace gate d) Clean chest area of valve
Valve jerks during open and close	Superstructure fasteners loosened	Tighten the superstructure fasteners
	Insufficient air supply	Pneumatic operated valves; increase supply pressure
	Solenoid valve dust accumulation	Remove and clean solenoid valve
	Piston rod seal damaged	Replace seal
	Packing is too tight	Loosen packing

APPENDIX A

BOLTING TORQUE SEQUENCE

DIAGRAM 1

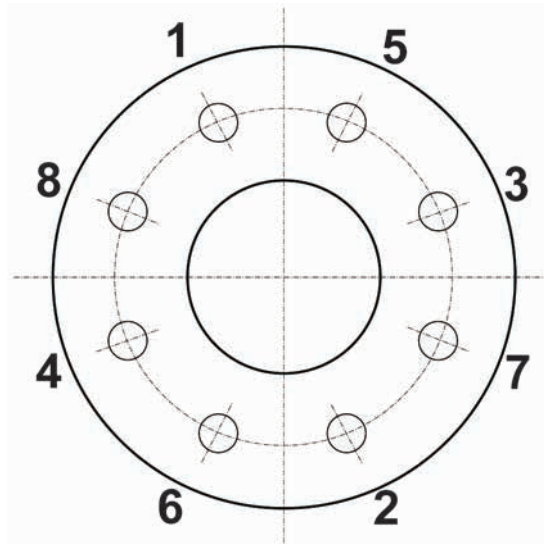

Bolting torque sequence: 1 - 2 - 3 - 4 - 5 - 6 - 7 - 8

Example only, number of bolts will vary, apply the same criss-cross process, gradually tightening more after each revolution.

Carefully place the valve between the flanges and loosely assemble the valve by putting in the bottom two or three studs, then carefully insert the gaskets into place. The bottom studs will help locate the gasket and hold it in position.

Carefully insert the balance of the studs into place and tighten all of them evenly by using the cross-over pattern. Do not tighten in rotation.

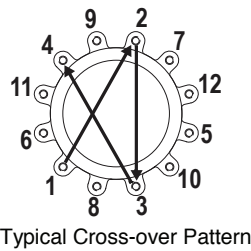

Caution

Do not overtighten chest cavity studs.

APPENDIX B

DESIGN

Flanging

ANSI B16.1/B16.5 125lb/150lb
 AS 2129 Table D, E
 AS 4087 PN14, PN16
 AS 4331.1 PN10, PN16
 EN 1092-2 PN10, PN16
 ISO 7005-1 PN10, PN16

Pressure/Class Rating

PN10 Rated body.
 Long term maximum packing rating:
 10 bar to 250NB
 7 bar 300 ~ 450NB
 4 bar 500 ~ 600NB

Face to Face Dimensions

AS 6401 & MSS SP-81

Test Standards

MSS SP-71, ISO 5208, MSS SP-61

Pressure/Temperature Rating Seat

NBR 10 bar -10°C to 90°C
 EPDM 10 bar -10°C to 120°C
 Viton 10 bar -10°C to 200°C
 PTFE 10 bar -10°C to 200°C
 Metal to Metal 10 bar -10°C to 200°C

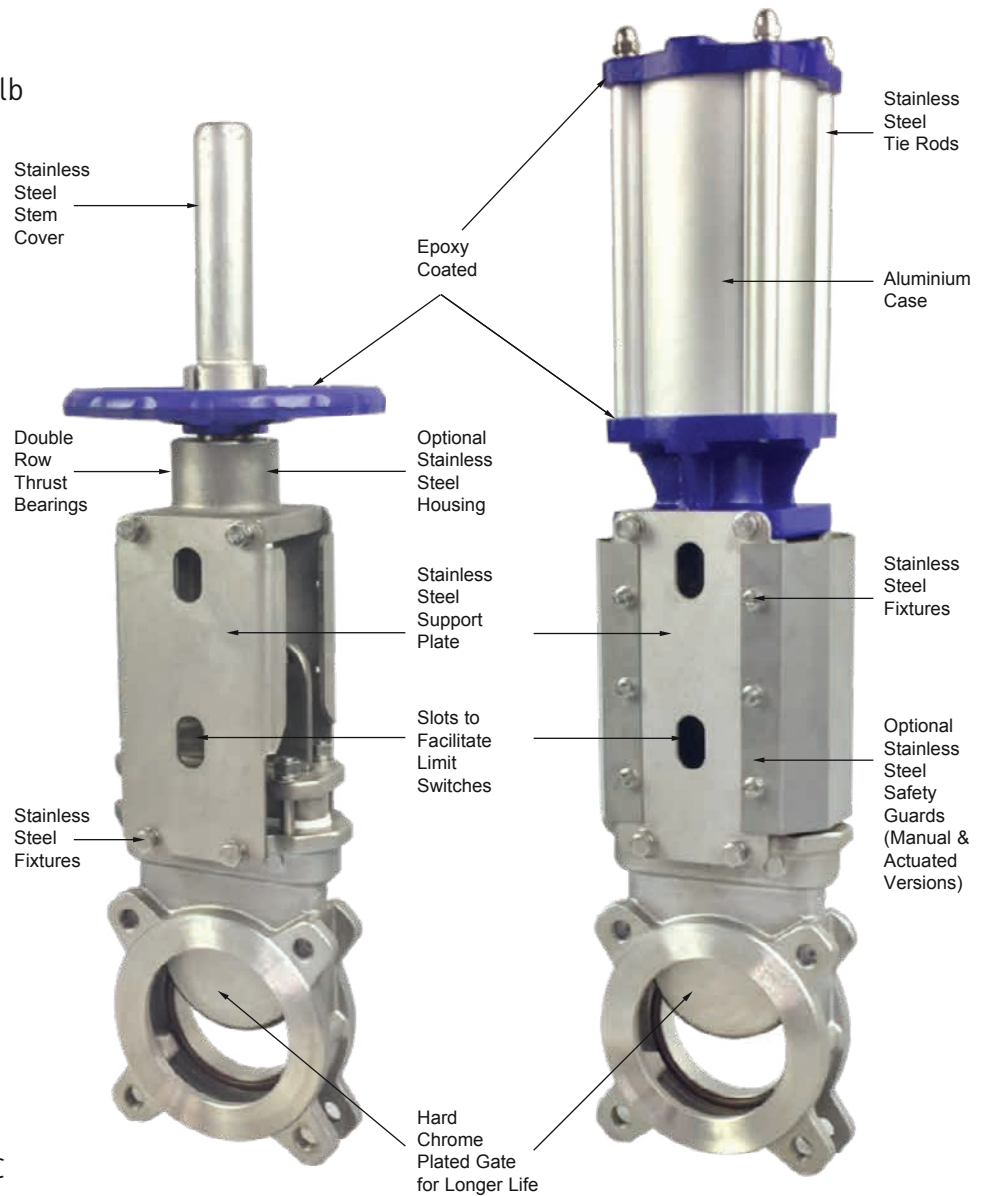

Resilient seated bi-directional valves are tested leak tight up to 4 Bar (Elastomer) on seat. Above 4 Bar rate is estimated at up to 2.66 drops/minute/inch (0.11 drips/minute/DN) as per MSS-SP61. However an actual seat test can be performed above 4.0 Bar if required. Special packing systems and bonnet designs are available for high pressure applications.

APPENDIX C

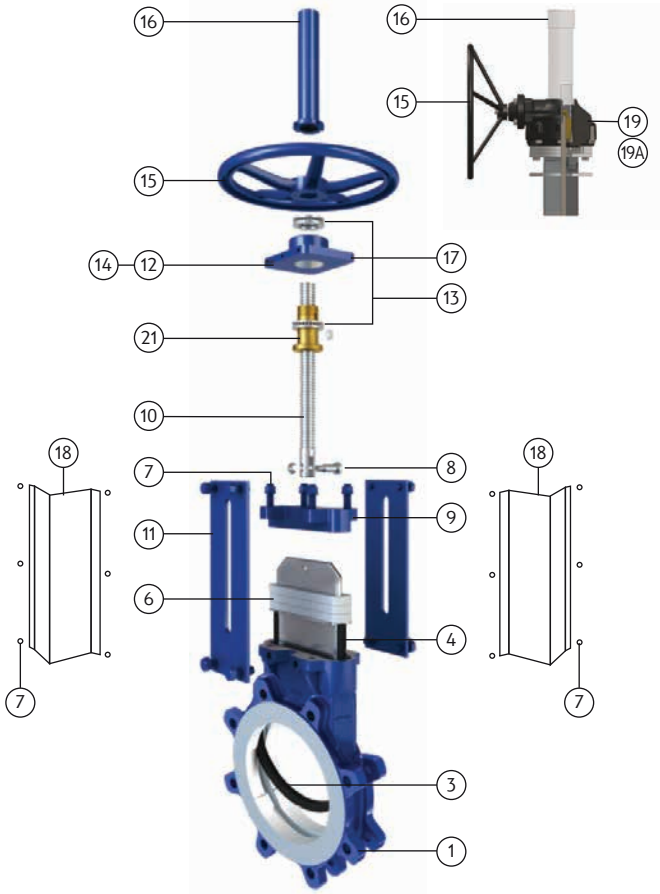

MATERIALS

NO.	PART NAME	MATERIAL	
		Handwheel Operated	Gear Operated
1	Body	Ductile Iron	Ductile Iron+FBE
3	Seat Encapsulated	Viton	
4	Gate	SS304+HCr	
6	Packing Multi-Layer	PTFE Braided+Silicon+PTFE Sheet	
7	Bolts & Nuts	A2-70 (SS304)	
8	Pins	SS304	
9	Gland	ASTM A216 WCB	ASTM A216 WCB+FBE
10	Stem	2CR13SS (420SS)	
11	Support Plates	Steel+FBE	Q235 Steel+FBE
12	Bearing Housing	SS304	
13	Bearings	SS440	
14	Bearing Cover	SS304	
15	Handwheel	Epoxy Coated Iron	
16	Stem Cover	SS304	
17	Grease Fitting	C95200+2P	
18	Safety Gate Guards	SS304	
19	Gearbox	-	Assembly
20	Grease Fitting	-	Brass+ZP
21	Stem Drive Nut	Aluminium Bronze	Brass H62

GLAND PACKING

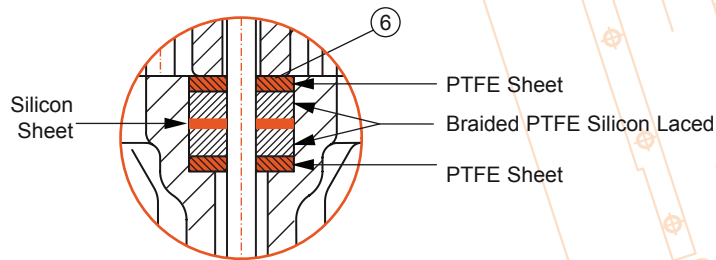

SEAT AREA



Representative example only, refer as-built drawing

CLOSE UP VIEW SEAT

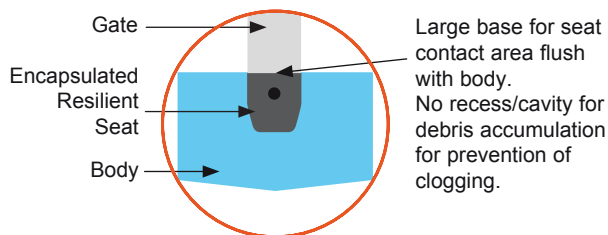

GUIDE CLAWS

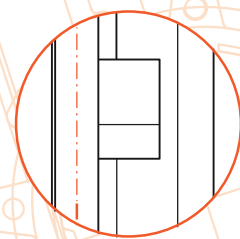

APPENDIX D

MATERIAL LIST - MANUAL OPERATED

ITEM	PART NAME	MATERIAL	
		Handwheel Operated	Gear Operated
1	Body	GGG40 Ductile Iron (1) (4) (5)	GGG40 Ductile Iron (1) (4) (6)
3	Seat	Viton (3) Encapsulated	
4	Gate	SS304+HCr (2)	
6	Packing Multi Layer	Braided PTFE+Silicon+PTFE Sheet	
7	Bolt	A2-70 (SS304)	
7A	Nut	A2-70 (SS304)	
8	Pin	2CR13	2CR13SS
9	Gland	ASTM A216 WCB	ASTM A216 WCB (1)
10	Stem	2CR13SS	
11	Support Plates	Q235 Steel (1)	
12	Bearing Housing	SS304	
13	Bearings	SS440	
14	Bearing Cover	SS304	
15	Handwheel	Epoxy Coated Iron (1)	
16	Stem Cover	SS304	
17	Grease Fitting	C95200+ZP	
18	Safety Gate Guards	SS304	
19	Bevel Gear (Ratio 4.5:1)	-	Fast Acting (1) (4)
21	Stem Drive Nut	H=Ni-Aluminium Bronze C95800	H62 Brass (Copper Zinc Alloy)

Indicative only, refer as-built drawing

- (1) Fusion bonded epoxy
- (2) Hard chromed both sides. Flat polished edge
- (3) Replaceable seat, full port
- (4) C/w grease fitting
- (5) Integral design ensures no shell leakage
- (6) Equivalent ISO 1083/JS/400-15/S, AS 1831-400-15, EN 1563 EN-GJS-40015

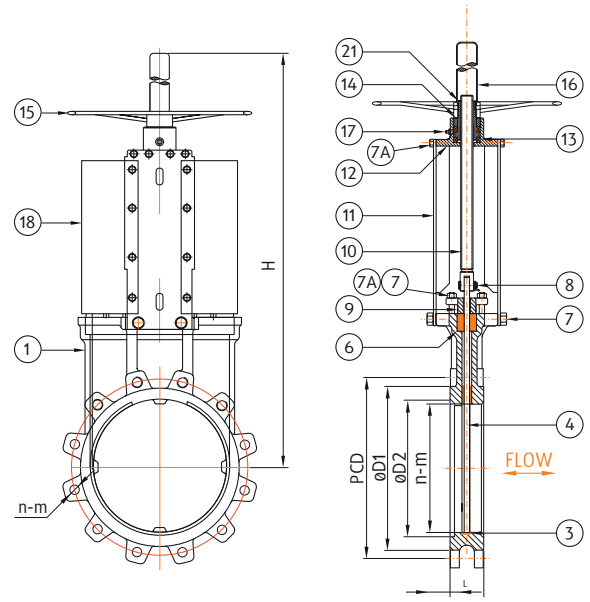

Handwheel Operated

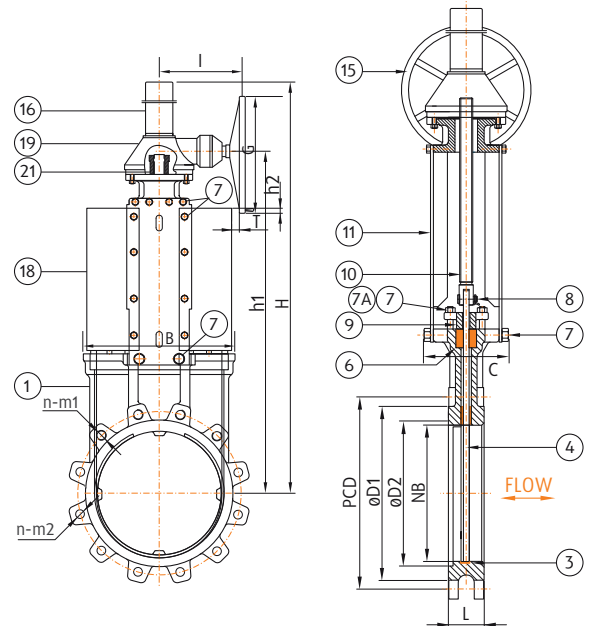

Gear Operated

DIMENSIONS & WEIGHTS (MM & KG)

AS 2129 Table D*/AS 4087 CL14/16

NB	L	H	PCD	øD1	øD2	n-ød1	n-ød2	h1	h2	T	Weight
50	48	302	114	90	60	-	4-M16	-	-	-	9.0
65	48	345	127	103	75	-	4-M16	-	-	-	11.0
80	51	365	146	122	90	-	4-M16	-	-	-	12.0
100	51	410	178	154	105	-	4-M16	-	-	-	16.0
125	57	460	210	186	130	-	8-M16	-	-	-	20.0
150	57	505	235	211	158	-	8-M16	-	-	-	25.0z
200	70	615	292	266	210	-	8-M16	-	-	-	43.0
250	70	740	356	324	260	-	8-M20	-	-	-	62.0
300	76	1415	406	378	310	4-M20	8-M20	856	25	30	78.0
350	76	1590	470	429	360	4-M24	8-M24	982	25	30	112.0
375	76	1740	495	489	415	4-M24	8-M24	1083	30	35	145.0
400	89	1810	521	532	465	4-M24	8-M24	1265	30	35	154.0
450	89	1950	584	609	515	4-M24	8-M24	1375	15	85	154.0

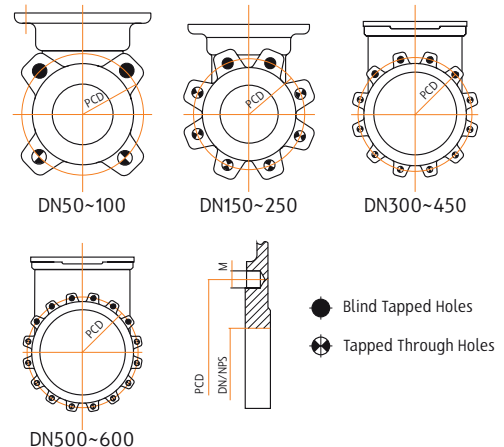

APPENDIX E

MATERIAL LIST - DOUBLE ACTING ACTUATED VALVE

ITEM	PART NAME	50mm~300mm	400mm & Above
1	Piston Rod	1045+Hardchrome/304SS	1045+Hardchrome/304SS
2	Bottom Cover	Epoxy Coated Steel	Epoxy Coated Steel
3	Wear Ring	PTFE+Cu	PTFE+Cu
4	O-Ring	NBR/Viton	NBR/Viton
5	O-Ring	NBR/Viton	NBR/Viton
6	O-Ring	NBR/Viton	NBR/Viton
7	Piston	Aluminium Alloy	Cr Plated 1045
8	Cylinder Tube	Aluminium Alloy	Cr Plated 1045
9	Bolt	A2-70	A2-70
10	O-Ring	NBR	NBR
11	Stroke Adjuster	A2-70 SS	A2-70 SS
12	Cover Caps	Epoxy Coated Steel	Epoxy Coated Steel
13	Tie Rod	A2-70 SS	A2-70 SS
14	Seal Retainer	SS304	SS304
15	Scraper Seal	PTFE	PTFE
16	Bolt	A2-70 SS	A2-70 SS
17	O-Ring	NBR/Viton	NBR/Viton
18	V-Ring	Polyurethane	Polyurethane
19	Shaft Bearing	Brass	Brass
20	Shaft Seal	EPDM/NBR/Viton	EPDM/NBR/Viton

* Metal and PTFE version only.

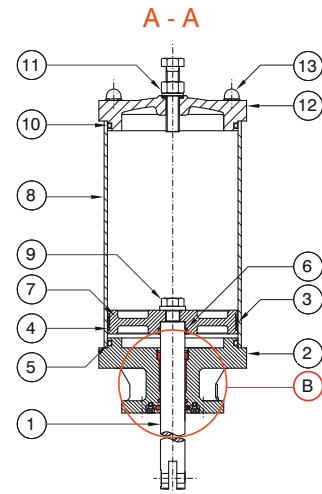

Exploded View B

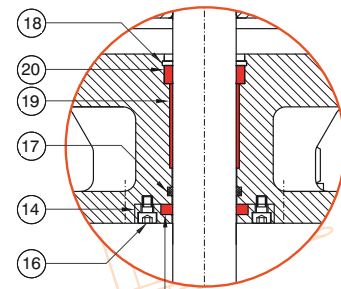

DIMENSIONS & WEIGHTS - ACTUATED VALVE (MM & KG)

NB	H	W	Cylinder Bore	Stroke	Air Connect	Cylinder Weight	Valve & Actuator Weight
50	457	100	80	60	F1/4	6.3	15.0
65	505	100	80	75	F1/4	6.3	17.0
80	545	120	100	85	F1/4	6.3	18.0
100	615	120	100	105	F1/4	6.3	22.0
125	680	150	125	135	F1/4	9.2	29.0
150	780	150	125	160	F3/8	9.2	34.0
200	950	195	160	210	F3/8	26.0	69.0
250	1135	240	200	260	F3/8	39.0	101.0
300	1320	280	250	310	F3/8	60.0	138.0
350	1510	395	300	360	F3/8	103.0	215.0
375	1610	395	300	410	F3/8	103.0	230.0
400	1650	395	300	410	F3/8	103.0	250.0
450	2005	423	350	460	F3/8	136.0	320.0
500	2285	423	350	510	F3/8	138.0	360.0
600	2385	440	400	610	F3/8	146.0	392.0

Refer to APV sizing guide. Air supply 4 bar to 7 bar

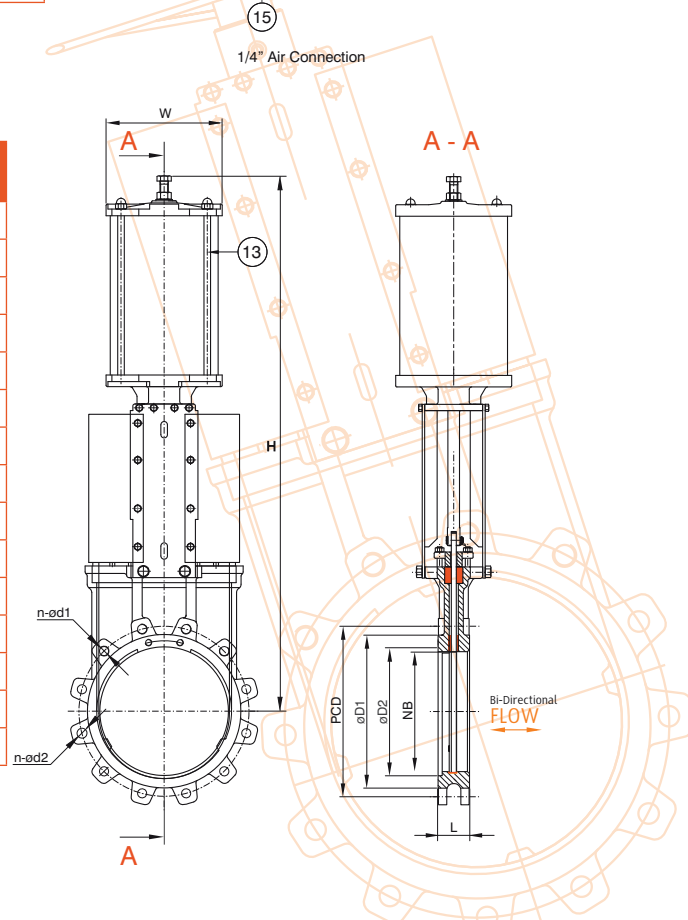

APPENDIX F

SEAT & CYLINDER SELECTION

RESILIENT SEAT SERVICE APPLICATIONS

The following is general information and materials required for special application should be specified.

Common Name	ASTM Code	Max. Temp	Mild Abrasion	Aging	Water Resistance	Oil Resistance	Solvent	Strong Acid	Weak Acid	Strong Alkali	Weak Alkali
Buna-N/NBR	NBR	93°C	∅	□	t∅	∅	□ ~ X	X	∅	∅	∅
Neoprene	CR	93°C	∅	∅	∅	□	X	X	□	∅	∅
Natural Rubber	NR	65°C	∅	∅	∅	X	X	X	∅	∅	∅
EPT	EPDM	121°C	∅	∅	∅	X	X	△	□	△	∅
Silicon	Si	160°C	∅	∅	∅	X ~ □	□	X	∅	∅	∅
Viton	FPM	160°C	□	□	∅*	∅	∅	∅*	∅	∅	∅
PTFE	D-1457	160°C	∅**	∅	∅	∅	∅	∅	∅	∅	∅

* Cold only, not hot. **High impact resistant.

Note: ∅ Excellent, □ Good, △ Fair, X Poor

SIZING INFORMATION FOR HEAVY DUTY AIR CYLINDER OPERATOR DC SERIES

Cylinders for air, oil and water for Knife Gate Valves with line differential pressures of 276 kPa through 552 kPa. This is a rough estimatings guide. Sizes shown is the bore of the cylinder.

Actuator Air Supply		276 kPa. Air		345 kPa. Air		414 kPa. Air		483 kPa. Air		552 kPa. Air		621 kPa. Air		689 kPa. Air	
Valve Size (mm)	Valve Size (in)	Cylinder Size		Cylinder Size		Cylinder Size		Cylinder Size		Cylinder Size		Cylinder Size		Cylinder Size	
		M	R	M	R	M	R	M	R	M	R	M	R	M	R
80	3"	102	100	100	100	76	76	76	76	76	76	64	64	64	64
100	4"	127	127	127	127	100	100	100	100	100	100	100	100	76	76
150	6"	152	152	152	152	125	125	125	125	125	125	125	125	100	100
200	8"	200	200	200	200	200	200	152	152	152	152	152	152	127	127
250	10"	254	254	250	250	200	200	200	200	200	200	200	200	150	150
300	12"	305	305	250	250	250	250	250	250	200	200	200	200	200	200
350	14"	356	356	300	300	300	300	250	250	250	250	250	250	200	200
400	16"	406	406	350	350	300	300	300	300	250	250	250	250	250	250
450	18"	406	406	400	400	350	350	300	300	300	300	300	300	250	250
500	20"			400	400	400	400	350	350	350	350	300	300	300	300
600	24"							400	400	400	400	350	350	350	350

"M" indicates metal-seated valve

"R" indicates one side DCNP resilient-seated valve

This is a "ready reckoner" for 'DCNP' series - but is a guide only. Cylinder size varies depending on model, pressure, seat type, configuration and media. Service viscosity and other factors can dramatically effect sizing.

DCNP Actuator air supply .41 ~ .585 mpa operating minimum .375 mpa maximum .7 mpa

For slurry service next size up is required, lease consult us. Special slurry design valve required.

WARRANTY

- 1. LIMITED WARRANTY:** Subject to the limitations expressed herein, Seller warrants that products manufactured by Seller shall be free from defects in design, material and workmanship under normal use for a period of one (1) year from installation but in no case shall the warranty period extend longer than eighteen months from the date of sale. This warranty is void for any damage caused by misuse, abuse, neglect, acts of God, or improper installation. For the purpose of this section, “Normal Use” means in strict accordance with the installation, operation and maintenance manual. The warranty for all other products is provided by the original equipment manufacturer.
- 2. REMEDIES:** Seller shall repair or replace, at its option, any non-conforming or otherwise defective product, upon receipt of notice from Buyer during the Manufacturer’s warranty period at no additional charge. SELLER HEREBY DISCLAIMS ALL OTHER EXPRESSED OR IMPLIED WARRANTIES, INCLUDING, WITHOUT LIMITATION, ALL IMPLIED WARRANTIES OF MERCHANTABILITY AND FITNESS OR FITNESS FOR A PARTICULAR PURPOSE.
- 3. LIMITATION OF LIABILITY:** UNDER NO CIRCUMSTANCES SHALL EITHER PARTY BE LIABLE TO THE OTHER FOR INCIDENTAL, PUNITIVE, SPECIAL OR CONSEQUENTIAL DAMAGES OF ANY KIND. BUYER HEREBY ACKNOWLEDGES AND AGREES THAT UNDER NO CIRCUMSTANCES, AND IN NO EVENT, SHALL SELLER’S LIABILITY, IF ANY, EXCEED THE NET SALES PRICE OF THE DEFECTIVE PRODUCT(S) PURCHASED DURING THE PREVIOUS CONTRACT YEAR.
- 4. LABOUR ALLOWANCE:** Seller makes NO ADDITIONAL ALLOWANCE FOR THE LABOUR OR EXPENSE OF REPAIRING OR REPLACING DEFECTIVE PRODUCTS OR WORKMANSHIP OR DAMAGE RESULTING FROM THE SAME.
- 5. RECOMMENDATIONS BY SELLER:** Seller may assist Buyer in selection decisions by providing information regarding products that it manufactures and those manufactured by others. However, Buyer acknowledges that Buyer ultimately chooses the product’s suitability for its particular use, as normally signified by the signature of Buyer’s technical representative. Any recommendations made by Seller concerning the use, design, application or operation of the products shall not be construed as representations or warranties, expressed or implied. Failure by Seller to make recommendations or give advice to Buyer shall not impose any liability upon Seller.
- 6. EXCUSED PERFORMANCE:** Seller will make a good faith effort to complete delivery of the products as indicated by Seller in writing, but Seller assumes no responsibility or liability and will accept no back-charge for loss or damage due to delay or inability to deliver, caused by acts of God, war, labour difficulties, accidents, inability to obtain materials, delays of carriers, contractors or suppliers or any other causes of any kind whatever beyond the control of Seller. Under no circumstances shall Seller be liable for any special, consequential, incidental, or indirect damages, losses, or expense (whether or not based on negligence) arising directly or indirectly from delays or failure to give notice of delay.



AUSTRALIAN PIPELINE VALVE®

ADELAIDE • BRISBANE • PERTH



AUSTRALIAN PIPELINE VALVE® HEAD OFFICE
70-78 Stanbel Road Salisbury Plain South Australia 5109 Telephone +61 (0)8 8285 0033 Fax +61 (0)8 8285 0044
email: admin@australianpipelinevalve.com.au

www.australianpipelinevalve.com.au

LOCAL DISTRIBUTOR/AGENT

If you have any requirements in the field of valves, please contact us for a prompt response. Continuous development of Australian Pipeline Valve products may necessitate changes in the design or manufacture process. Australian Pipeline Valve reserves the right to effect any such changes without prior notice.

