

FLOATING BALL VALVES

BV100 SERIES

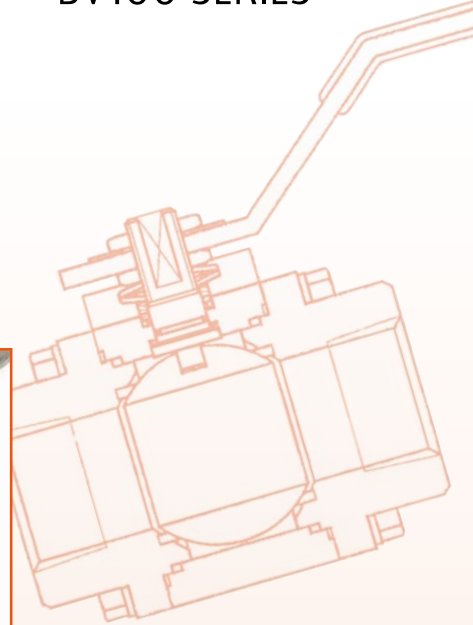

**AUSTRALIAN
PIPELINE VALVE®**



AUSTRALIAN PIPELINE VALVE®

COMPLETE PRODUCT LINE

“Australian Pipeline Valve produces isolation, control and flow reversal protection products for severe and critical service media in utility, steam, pipelines, oil & gas and process industries. APV valves and pipeline products form the most competitive portfolio in the market.”



SUPER-CHECK®



TORQTURN®

TWIN-LOK®

UNIFLO®



AUSTRALIAN PIPELINE VALVE BRAND RANGE - CATALOGUES

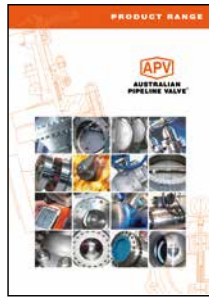

Product Brochure



Ball Valves Floating & Trunnion Mounted



Ball Valves Floating Small Bore

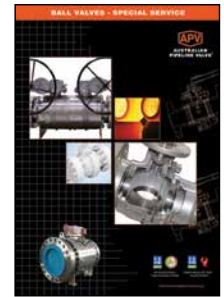

Ball Valves Special Service



Gate, Globe & Check Valves - Cast Steel

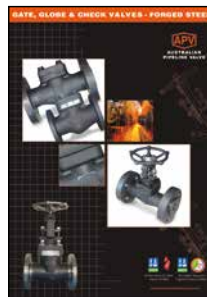

Gate, Globe & Check Valves - Forged Steel

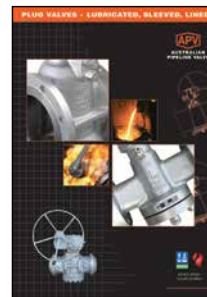

Plug Valves Lubricated, Sleeved & Lined

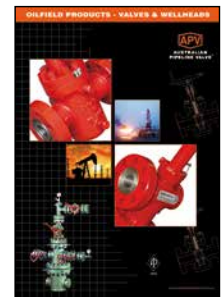

Oilfield Products Valves & Wellheads

APV FAMILY OF BRANDS RANGE - CATALOGUES



Diamond Gear Gearboxes

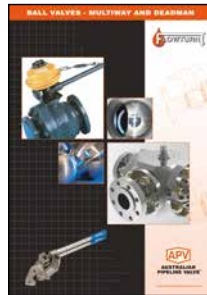

Flowturn Ball Valves Multiway & Deadman



Flowturn Gate, Globe & Check Valves



Flowturn Instrument Valves



Flowturn Strainers & Sight Glasses



Steamco Steam Valves



Supercheck Wafer Check Valves



Superseal Butterfly Valves

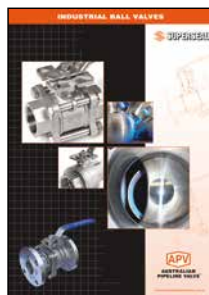

Superseal Industrial Ball Valves



Torqturn Actuators

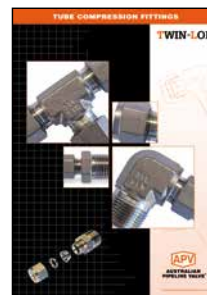

TwinLok Tube Fittings

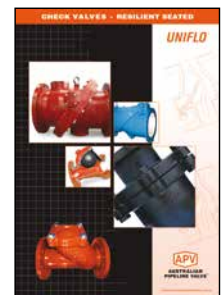

Uniflo Check Valves

Contact us for your local stockist/distributor

INDEX



Introduction	2
Safety Information	4-5
1.0 Scope	5-6
1.1 Environmental considerations	5
1.2 Storage	5
1.3 Preparation	6
2.0 Installation	6-10
2.1 Installation positions	7
2.2 Preparation for installation	7
2.3 End connections	7-8
2.4 Valve installation by welding	8-10
3.0 Operation	10
3.1 Manual operation	10
3.2 Lock device	10
4.0 Maintenance	10-15
4.1 Gland packing	11-12
4.2 Body seal	12-13
4.3 Inspection and replacement of trim components	13-14
4.4 Disassembly procedure	14
4.5 Reassembly procedure	14-15
5.0 Construction - Typical bill of materials	16
Appendix A - Bolting torque's	17-18
Appendix B - Exploded B.O.M.	19

INTRODUCTION

The majority of this information is common knowledge to experienced valve users. When properly installed in applications for which they were designed, Australian Pipeline Valve (APV) valves will give long reliable service. This instruction is only a guide for installation and operation on standard service and covers general maintenance and minor repairs. A professional APV approved valve engineering facility should be utilised for reconditioning or major repairs. Check the part number on the label to ensure the valve is configured to firesafe specifications if firesafe is required.



Note

We recommend that this entire document be read prior to proceeding with any installation or repair. Australian Pipeline Valve and its parent company take no responsibility for damage or injury to people, property or equipment. It is the sole responsibility of the user to ensure only specially trained valve repair experts perform repairs under the supervision of a qualified supervisor.

RESPONSIBILITY FOR VALVE APPLICATION

The User is responsible for ordering the correct valves. The user is responsible for ensuring APV Valves are selected and installed in conformance with the current pressure rating and design temperature requirements. Prior to installation, the valves and nameplates should be checked for proper identification to ensure the valve is of the proper type, material and is of a suitable pressure class and temperature rating to satisfy the requirements of the service application.



Caution

Do not use valves in applications where either the pressure or temperature is higher than the allowable working values. Also valves should not be used in service media if not compatible with the valve material of construction, as this will cause chemical attacks, leakage, valve failure.

RECEIVING INSPECTION AND HANDLING

Valves should be inspected upon receipt to ensure:

- Conformance with all purchase order requirements.
- Correct type, pressure class, size, body and trim materials and end connections.
- Any damage caused during shipping and handling to end connections, hand wheel or stem.



Caution

The User is advised that specifying an incorrect valve for the application may result in injuries or property damage. Selecting the correct valve type, rating, material and connections, in conformance with the required performance requirements is important for proper application and is the sole responsibility of the user.

CONSIDERATIONS OF TECHNICAL RISK/ LIMIT OF LIABILITY TO CLIENT FOR BALL VALVES

Australian Pipeline Valve don't consider in our design the following factors of risk:

1. Australian Pipeline Valve 'Standard' ball valves can be used in a temperature range between -28.8 to +200°C. (Note, pressure limitations apply above 38°C refer to Pressure/Temperature charts.) For service temperatures below -28.8°C ball valve construction materials shall be submitted to an impact test at the minimum service temperature. For temperatures outside of the range of -28.8°C to +200°C ball valves have to be provided with seats, seals and body material able to withstand the temperature degree required.
2. The onus is on the customer to specify all materials of construction and service conditions. Australian Pipeline Valve shall assume standard materials and conditions if not otherwise specified.
3. Australian Pipeline Valve 'Standard' ball valves are not equipped with devices suitable to avoid internal over-pressures caused by incorrect operations of process or by-fluids & liquids subjected to an increase of volume and/or pressure (these devices, such as the over-pressure hole in the ball or safety seats are available upon request).
4. Australian Pipeline Valve 'Standard' ball valves are not designed with special devices to withstand a sudden thermal jump (thermal shock).
5. In general Australian Pipeline Valve 'Standard' ball valves are not mechanically designed to bear overloads due to exceptional atmospheric or natural phenomenon's (such as earthquakes).
6. In general Australian Pipeline Valve 'Standard' ball valves are not designed to bear loads on flanges, on pipe connections or pipeline.
7. In general Australian Pipeline Valve 'Standard' ball valves can't withstand ice inside their bodies (in this case user must specify the optional stem extension for insulating, avoiding the presence of residual product inside the valve).
8. Australian Pipeline Valve 'Standard' ball valves are not suitable for low temperature service below -29°C (-20°F) unless provided with cryogenic stem extension and other modifications (available on request).
9. Australian Pipeline Valve 'Standard' ball valves are suitable for 'industrial' oxygen (not medical) service when supplied degreased and packed in polyethylene bags only.
10. The compatibility between ball valves construction materials and medium is selected by the user. The user is ultimately responsible for verifying the compatibility between medium and materials.
11. Abrasive or dirty service, high temperature service, low temperature service, vacuum service, near zero pressure service and other special applications should be clearly stated when requesting quotation.

BALL VALVE START-UP

Before installing the ball valve onto the pipe-line it is mandatory for the user to verify the compatibility of the ball valve with service conditions (medium, temperature and pressure). With reference to standard ball valves held in stock the reseller and end user will have to assure themselves of the compatibility with the use of conditions required by the customer. Australian Pipeline Valve ball valves must be only used for on-off (fully open/fully closed) service.

Before using the ball valve in a potential explosive atmosphere it's necessary: -

- To verify the compatibility between the ball valve and the zone in which the ball valve should be installed.
- To foresee the pipe-line ground condition on which the ball valve should be installed.
- To check that the temperature of the ball valve surface is not higher than the flammable point of the atmosphere in which the ball valve is installed (in this case specify an insulating cover device for the valve and an extension for the wrench)
- Before installing ball valves with welding ends to make sure that the process of welding is carried out in accordance with all the safety requirements of the classified zone.
- To avoid mechanical knocks during the installation that may cause sparks.

Australian Pipeline Valve cannot be held responsible for damage caused by use of the product especially if it is improper use or modified.

SAFETY INFORMATION

The following general safety information should be taken in account in addition to the specific warnings and cautions specified in this manual. They are recommended precautions that must be understood and applied during operation and maintenance of the equipment covered in this I.O.M.



Never attempt to disassemble a valve while there is pressure in the line. Ensure both upstream and downstream pressures are removed. Disassemble with caution in case all pressures are not relieved. Even when replacing stem packing, caution is necessary to avoid possible injury.



To prevent valve bending, damage, inefficient operation, or early maintenance problems, support piping on each side of the valve. When handling gases/fluids that could cause damage to human health, the environment or property, the necessary precautions to prevent risk must be taken.



- *A valve is a pressurised mechanism containing energised fluids under pressure and consequently should be handled with appropriate care.*
- *Valve surface temperature may be dangerously too hot or too cold for skin contact.*
- *Upon disassembly, attention should be paid to the possibility of releasing dangerous and or ignitable accumulated fluids.*
- *Ensure adequate ventilation is available for service.*

This manual provides instructions for storing, general servicing, installation and removal of ball valves. APV and its resellers refuse any liability for damage to people, property or plant as well as loss of production and loss of income under any circumstances but especially if caused by: Incorrect installation or utilisation of the valve or if the valve installed is not fit for the intended purpose. It is the sole responsibility of the user to ensure the valve type and materials are correctly specified.

SCOPE OF INSTALLATION ACCORDING TO THE TYPE OF FLUID

(DANGEROUS FOR THE ENVIRONMENT OR HUMAN HEALTH)

Group 1 Classification

- The incorporation of additional safety elements “Double Packing” (utilising a stem extension) is recommended for the range of products included in Group 1.
- The use of valves without additional safety devices in Group 1 will be the responsibility of the user or the purchaser, as well as the advisability of installing leakage detection systems.

Group 2 Classification

- Carbon steel valves will not be used in corrosive fluid lines.

DURING OPERATION TAKE INTO ACCOUNT THE FOLLOWING WARNINGS:

- a- Graphite/Graphoil packing and body gasket is very brittle, any impacting, twisting or bending should be avoided.
- b- The valve's internal parts such as ball, stem, seats, seals, gaskets shall be handled with care avoiding scratches or surface damage.
- c- All tools and equipment for handling internal critical sealing parts shall be soft coated.
- d- Valves can be fitted with gaskets or seals in PTFE, Buna, Viton, etc., hence high temperatures will damage sealing components.
- e- Never part open valve, valve must be full open or full closed to avoid seal damage.

For all operations make reference to position number on part list of the applicable drawing listed.

1.0 SCOPE

This manual describes the methods of installation and maintenance for floating ball valves, which are designed to fit between ANSI Class 150, Class 300 and Class 600 flanges or with butt weld ends.

1.1 ENVIRONMENTAL CONSIDERATIONS

According to ISO 14000 regulations and the environmental policy of APV the recyclability of the components that form part of APV valves is as follows:

Recyclable components:

Metal parts, PTFE (hard), plastic plug (low-density polyethylene).

Non-recyclable components:

PTFE mixed with other compounds (glass-fiber, graphite, etc.), nylon, graphite and graphite mixed with metal.

1.2 STORAGE

1.2.1 Temporary Storage

If valves are to be stored before installation, the following should be observed:

- a) Keep the valves wrapped and protected as shipped from the manufacturer.
- b) Do not remove the protective end covering until the valve is ready for installation. This will reduce the possibility of foreign material damaging the internal valve components.
- c) Valves stored outdoors should be positioned such that water does not accumulate in the valve body.

1.2.2 Long Term Storage

If valves are to be stored more than one year, they should be prepared in the following manner:

- a) Remove the packing and apply a preservative to the packing chamber.
- b) Do not remove the protective end covering.
- c) Do not store the valves outdoors.

1.3 PREPARATION

- a) Remove the valve end protection.
- b) Prior to shipment, a preservative/corrosion inhibitor may have been applied to the inner body of the valve. This preservative/corrosion inhibitor can be removed with a solvent provided the solvent used does not affect the seats/seals used in the valve.
- c) The inside of the valve should be inspected and blown out with compressed air. Adjacent piping must be clean and free from debris to prevent damage to the valve.
- d) To prevent valve distortion, inefficient operation or early maintenance problems, support piping on each side of the valve.
- e) Make sure the valve is positioned such that there is sufficient space so that the hand wheel is easily and safely reached and there is enough clearance for the stem when the valve is open.
- f) Install the valve according to the flow indicator on the valve body where applicable.

2.0 INSTALLATION



Piping should be properly aligned and supported to reduce mechanical loading on end connections. Never use the lever (wrench) to hold the valve during transport, handling or assembly.

The following procedure is required to be followed for correct installation.

- a) Before installation confirm the marking (rating, size and material) on the valve body and nameplate. Ensure the valve is suitable for the service which it is being used.
- b) Body bolts and nuts on valve shall be checked and retightened if necessary in case loosened during installation.
- c) Remove valve end protectors and ensure gasket faces are free from damage. Tighten all bolts between mating flanges and valve equally paying careful attention to properly tighten bolts. Ensure you rotate tightening procedure (opposing bolts sequentially) gradually increasing torque. Refer to Appendix Table 2 for bolt tightening sequence.
- d) Prior to installation of valve, ensure the line is completely flushed to remove any debris as soft seated ball valves are easily damaged. Filters or strainers should be installed upstream to protect soft seated valves.
- e) Valves will operate at any angle horizontally or vertically, although it is recommended you install valves in a vertical position with stem pointing upwards for ease of operation, inspection and accessibility.

2.1 INSTALLATION POSITIONS

Ball valves are usually bi-directional, and therefore may be installed in either direction. In some cases, ball valves such as 'metal to metal' seated and low temperature valves may be uni-directional, in which case the direction of flow will be indicated on the valve body.

2.2 PREPARATION FOR INSTALLATION

- Remove protective end caps or plugs and inspect valve ends for damage to threads, weld ends or flange faces.
- Thoroughly clean adjacent piping system to remove any foreign material that could cause damage to seating surfaces during valve operation.
- Verify that the space available for installation is adequate to allow the valve to be installed and to be operated.



Caution

Ensure sufficient clearance for the stem in the full open position. Inadequate clearance for valves may add mechanical loading to the valve ends. Sufficient clearance should be allowed for threaded end valves to be 'swung' during installation.

2.3 END CONNECTIONS

2.3.1 Threaded Ends

Check condition of threads on mating pipe. Apply joint compound to the male end of joint only. This will prevent compound from entering the valve flowpath.

2.3.2 Flanged Ends

Check to see that mating flanges are dimensionally compatible with the flanges on the valve body ensure sealing surfaces are free of debris. Install the correct studs and nuts for the application and place the gasket between the flange facings.



Caution

Stud nuts should be tightened in an opposing criss-cross pattern in equal increments to ensure even gasket compression.

2.3.3 Socket weld Ends

Remove all debris, grease, oil, paint, etc., from the pipe that is to be welded into the valve and from the valve end connections.

Insert the pipe into the valve end connection until it bottoms out in the socket weld bore. Withdraw the pipe 1/16" so that a gap remains between the pipe and the bottom of the socket weld bore to prevent cracks (ASME B16.11). Tack the pipe into the valve and complete the fillet weld.



Caution

WELDING INSTRUCTIONS

- Local welding regulations and specification must be complied with when carrying out welding work.
- Remove any paint and rust around the weld area on the pipe and welded end of the ball valve.
- Check that the ball valve is correctly positioned and aligned with the pipeline.
- Where weld connection is close to seat area, due to short length of the welded ends there is a risk that the soft inserts may be destroyed during the welding work. Hence the following procedure is advised: -

Use temperature measuring strips to check that the temperature does not rise beyond the permissible limits (160°C). The strips must be fitted to the connection near the soft inserts. These temperature measurements strips are designed so that, when a type-dependent temperature is reached, the colour irreversibly changes from white to black. The temperature measurement strip must be monitored constantly throughout the welding work. If any change of colour is noticed, the welding work must be interrupted immediately and the weld allowed to cool. For 'swing out centre' design, the centre section containing soft parts can be removed during welding if preferred, see 2.4.1.

2.3.4 Buttweld End Valves

Clean the weld ends as necessary and weld into the line using an approved weld procedure. Make sure the pipe and valve body material given on the valve body or nameplate is compatible with the welding procedure. (Refer our compatibility cross reference chart for equivalent pipe, valve & fittings grades at the Technical section of our website). Soft seats can be damaged during welding, take steps to ensure valve is not over heated, especially smaller size valves (see above caution note).

2.4 VALVE INSTALLATION BY WELDING

For all sizes of valves, leave valves in the full open position during installation, welding and post-weld heat treatment. This will reduce temperature transmission to soft seats. After welding completion, open the valve and flush line to clean out any foreign matter. Valves over 65 NB (2 1/2") have minimal risk of temperature damage to seats.

2.4.1 Disassembly Method

For valves up to 80 NB (3") the welding temperature can adversely affect the PTFE and elastomer components. Follow the welding instructions above but also use temperature measuring strips to monitor

temperature. It will be the responsibility of the operator to ensure valves are kept cool during welding and then post-weld testing of the valve should be performed. Larger size valves over 80 NB (3") are less likely to transmit heat to seat and stem packing during welding but still care should be taken. The 'swing out' version of BV100 Series valve can be disassembled prior to welding to avoid damage to seats and body seals (only 3 bolts need to be removed to 'swing out' the centre section of the remaining bolt). Ensure the centre section of the valve is 'swing out', typically only 800 class up to 50 NB (2") are 'swing out' design. The seats and seals remain in the centre section hence no seat or seal removal is required. If this option is recommended by APV then these valves have in-line removable sections hence no line movement is necessary to insert the fully self contained centre section. There must be sufficient movement in line to allow tightening of body bolts to compress the body gasket. In class 1500 and 2500 the disassembly method cannot be performed due to intersecting components.

- 1- Tack weld in 4 points on both end caps, leave the valve in the open position and do not move during and at least 30 minutes after welding until the valve cools. For socket weld also see 2.3.3, for butt weld also see 2.3.4.
- 2- Remove centre section and complete welding.
- 3- Replace centre section but first apply grease to the seat rings to aid the seat and torque (unless for oxygen service).

The below procedures should also be followed:

- a) Always ensure there is no pressure or product in the line. Ball valves will be supplied with socket weld ends to ANSI B16.11 or butt weld ends to ANSI B16.25. Welding should be done using procedures and welders qualified under section IX of the ASME boiler and pressure vessel code.
- b) For 1500 & 2500 class valves, if the body seats are removed, put them back in the same side from which they were removed and take care not to cut or scratch them. Smear some grease into the seat pocket to help them fit into pockets. (Don't apply grease if for oxygen service). If the valve leaks from the stem after assembly, try adjusting the stem packing. Always clean all welding surfaces from contamination, grease etc., prior to welding.

Note: For higher pressures and sizes, Delrin and PEEK seats may have graphite or PTFE backing rings.

- c) Always do as a low temperature weld as necessary to obtain a reliable connection. Use whatever measure necessary to localise heat at the joint, dissipating it before damage can occur to adaptor gaskets and/or seats (the main risk is seats). Use a tempil stick or other temperature indicator on the outside of the valve body (centre section) directly adjacent to adapter end piece) being welded to assure the body temperature does not increase 160°C. Always leave valve in open position during welding but also at least 60 minutes after welding unit valve cools.
- d) Where required APV will supply spare body gaskets. Graphite body gaskets are brittle so great care should be taken not to damage.

2.4.2 No Disassembly Method

Valves under 50 NB (2") that are not disassembled should have pup ends fitted to avoid seat damage. If not fitted ensure valve body temperature is kept cool. Temperatures over 180°C can damage seats & seals. In 1500 and 2500 class, BV100 valves have encapsulated seats, hence you must have 3mm of movement in your line in order to replace disassembled centre section, due to seats intersecting end cap

and centre pieces. You can still use disassembly method 2.4.1 above provided you have 3mm of line movement. APV will supply spare body gaskets where required. If you do not disassemble the valve, do not attempt to weld valves under 50 NB (2") that do not have pup ends unless you are using water cooling and monitoring the temperature.

For pup end valves and valves 50 NB (2") and over with short ends there is no need for disassembly, valves can be welded straight in line. There is no need to keep cool but if valve does not have extended long ends it still pays to ensure that the valve body near seat and body seal area remain below 150°C especially for valves 80 NB (3") and smaller.

The responsibility for welding of the valves into piping systems is that of those performing the welding. Refer to ASME B31.1, B31.3 etc. Written welding procedures covering all attributes of the process and materials to be welded shall be in accordance with Section IX of the ASME Boiler and Pressure Vessel Code and any additional requirements from the applicable piping code including any possible necessary localised post weld heat treatment depending on material specifications.

3.0 OPERATION

3.1 MANUAL OPERATION

Valve adjustment is by clockwise turning of stem. Lever operated and gear operated valves have a position indicator to indicate open or closed (see figure 1). Ball Valves must not be used for throttling. Do not leave part open, or seats will be damaged. Valve must be full open or full closed or damage to seats or body will occur.

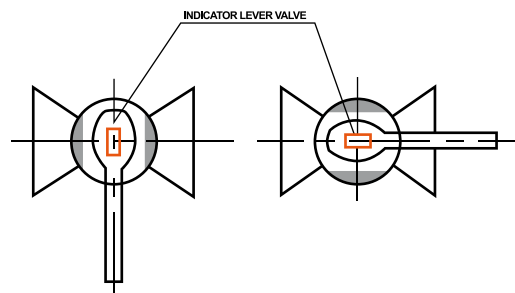

FIG 1.

3.2 LOCK DEVICE

Where provided (optional) the valve has a locking lug that allows valve to be locked in full open or full closed position.

4.0 MAINTENANCE

Valves should be periodically checked at least once every 3 months, but depending on service, criticality and frequency of use, more regular checking may be required.



Caution

Packing leakage could result in personal injury. Valve packing is tightened prior to shipping but may require adjustment to meet specific service conditions. If a valve does not fully close, damage to the seat and body will result due to the venturi effect resulting in high pressure erosion. Flush or remove the valve at next opportunity.

A good program of inspection and maintenance cannot be overstressed. It is recommended that the valve be periodically and at least partially stroked/function tested to ensure the valve functions and prevent seizure/sticking of any mating surfaces. Duration depends on service, criticality etc. However it also must be factored in that if there are impurities or particulates in the line each operation could reduce seat life proportionately. Periodic inspection of critical leak-path areas such as body/bonnet joint, end connections, seating surfaces, and around the stem packing should be a requirement.

The most common area for leakage is around the stem packing, this is usually due to wear and can normally be stopped by adjusting the packing. This procedure is performed by turning gland bolts or nut (9) 1/2 turn at a time until leakage stops. Once leakage stops, continue tightening gland plate nuts an additional 1/2 turn. If leakage cannot be halted by adjusting packing, repacking of the valve is indicated. (Refer to field repair).



Caution

Do not attempt to replacing packing or replace stem while the valve is in service! (The stem is blowout proof and can only be removed by disassembling the valve). Only graphite packing is to be used for firesafe service, PTFE is not firesafe. A BV100 valve is firesafe only when fitted with graphite packing and graphite or spiral wound graphite filled body gasket. Check the full part number on the label to ensure the valve is specified as firesafe. If there is no firesafe logo on the label the valve is not firesafe. If the port number indicates PTFE packing or body gasket the valve is not firesafe.

4.1 GLAND PACKING

In case of slight leakage from the gland, gland packing bolts can be lightly tightened up without effecting torque. (see 4.0) See Figure 2 and table 2 in the Appendix.

4.1.1 Stem Leakage – Stem Packing Replacement

The most common point for leakage is around the stem and packing this leakage can normally be stopped by adjustment of the packing gland. If this does not stop the valve leakage, the valve will have to be repacked.

The system and valve MUST be depressurised and removed from the line before attempting any repair work. After removing all pressure from the valve and draining the system the following procedure should be used to repack the valve.

1. Remove nuts or screw from the lever. Remove the lever and lock plate. Remove the gland nuts.
2. Remove old packing, taking care not to scratch or damage the stem of stuffing box. Note, the stem

design is anti-blow out so the stem cannot be removed up through the top of the valve.

3. Clean and inspect stem, stuffing box, and gland. If any scratches, nicks, or corrosion is found, the parts should be replaced.
4. Slide each packing ring over the stem and into packing chamber. Carefully tap each ring into place and continue installing rings until the recommended number of rings have been installed. A thin smear of molybdenum sulfide anti-seize grease may be used on the stem and packing chamber wall for packing lubrication.
5. Replace gland, and gland nuts. Tighten gland nut(s) alternately in 1/2 turn increments until a reasonable torque (refer table 2 in the Appendix) is applied to lightly compress packing. Lubricate stem and cycle valve through a couple of complete cycles.
6. If slight stem leakage occurs after system is pressurised, continue tightening gland plate bolts in alternating 1/2 turn increments until leakage stops. Once leakage stops, continue tightening gland plate nuts and additional 1/2 turn. There is also a PTFE seal ring/bearing and larger sizes/higher classes also have an elastomer o-ring. However, these parts can only be replaced during complete disassembly of the valve. If a PTFE stem o-ring is fitted it can be replaced with an elastomer o-ring suitable for the service medium and temperature. PTFE stem o-rings may require pre softening in hot water prior to fitting. Should replacement of packing fail to prevent the leakage, complete reconditioning of the valve may be required.



Caution

Personal injury may result from sudden release of any process pressure. APV recommends the use of protective clothing, gloves and eye wear when performing any installation or maintenance. Isolate the valve from the system and relieve pressure prior to performing maintenance. Disconnect any operating lines providing air pressure, control signals or electrical power to actuators.

NO.	DESCRIPTION
1	Thrust Seal Washer
2	Stem Packing
3	Gland
4	Belleville Spring Washers
5	Stem
6	Gland Nut
7	Spring Washer
8	Handle Nut
9	Packing Nut Lock Clip
10	Stem O-ring
11	Anti-Static Device
12	Lock Device

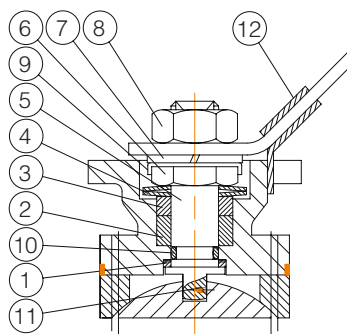

FIG 2. CONSTRUCTION FOR GLAND PARTS

(example only, refer to as-built drawing)

4.2 BODY SEAL

Sealing between three body segments is provided by a gasket (Teflon, spiral wound or graphite) and both valve segment surfaces also provide metal to metal sealing. In larger sizes or higher pressures an elastomer O-ring may also be used. In case of slight leakage the body fastening bolts can be lightly tightened up.



Caution

If a gasket seal is disturbed while removing or adjusting gasketed parts, APV recommends installing a new gasket while reassembling. A proper seal is required to ensure optimum operation.

4.2.1 Body Gasket Tightening

Should leakage occur at the body joint, tighten bonnet bolts to the values shown in Table 1 (refer Appendix). If after tightening body bolts, leakage continues, replacement of gaskets is recommended. A new gasket is recommended anytime the valve is disassembled. The following procedure shown in 4.3 is recommended for the replacement of the gasket and other trim components.

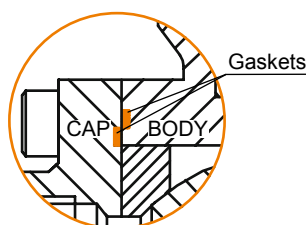

FIG 3. STRUCTURE OF GASKETS IN BODY JOIN

(example only, refer to as-built drawing)

4.3 INSPECTION AND REPLACEMENT OF TRIM COMPONENTS

Disassembly: -

1. Place the valve in the half open position and remove all pressure and drain the system. Make sure that leakage of any residual material is caught in an appropriate container and disposed of properly.
2. *For gear operator or power actuator operated:* - remove the bolt fastening the gearbox or power actuator. Remove the gear operator or power actuator. Remove the bolt fastening the yoke or yoke nut (depending on size/class).
3. *For lever operated:* - remove the nut fastening the lever. Remove the lever. Remove the retainer/lock nut/washer and the stop plate.
4. Follow disassembly procedure 4.4 below.
5. Remove the ball from the body. Check the ball for any damage. Remove the seat from the body. Check the seat for any damage.
6. Remove the stem and thrust plate from the body. Remove the thrust plate from the stem. Check the stem for any damage.
7. Clean and inspect body and retainer gasket surfaces. Check for erosion, corrosion, or damage, especially near point where leakage occurred. If damage is found, those surfaces must be repaired before continuing.
8. Replace or repair all damaged parts.

Reassembly: -

1. Installation of new seats, packing and seals is recommended, then follow reassembly procedure 4.5 below.
2. *For gear operator or power actuator operated:* - install the yoke and tighten the screws.
 - 2a. Install key on the stem.
 - 2b. Install gear operator on top flange and tighten the bolts.
3. *For lever operated:* - install stop plate.
 - 3a. Install retainer/thrust washer.
 - 3b. Install lever.
 - 3c. Install washer and tighten the screw or fit circlip.

This completes the reassembly.

4.4 DISASSEMBLY PROCEDURE

Before removing valve from line ensure valve is in the closed position and line is fully closed off and drained. Client should observe all industry & regulatory procedures in this process. To disassemble first remove the operator (4.3.2) then the following steps should be followed with reassembly in reverse order.

1. Drain & clean valve including contents in cavity.
2. Remove (2) BOLTS from (1) BODY and (4) CAPS.
3. Take off (4) CAPS from (1) BODY and remove (5) GASKET.
4. Carefully remove (15) BALL. Avoid scratching BALL surface.
5. Remove (3) SEATS from BODY and CAP.
6. Remove (11) STEM NUT, (10) LEVER, (9) GLAND NUT, (15) STOPPER, (17) STOP WASHER, (16) SPRING WASHER, and (8) GLAND RETAINER (parts can vary according to size, class. Refer to as-built drawing).
7. Remove (12) STEM by pulling from inside BODY cavity.
8. Remove (6) THRUST WASHER.
9. Remove (7) GLAND PACKING and (20) STEM SEAL where fitted.

4.5 REASSEMBLY PROCEDURE



Caution

Check the packing box for pressurised process fluids even after the valve has been removed from the pipeline, particularly when removing packing hardware or packing rings, or removing packing box pipe plug.

1. For reassembly of the disassembled valves, follow the above disassembling procedure in the reverse order.
2. After cleaning the disassembled parts, reset each part in the original position properly. The threaded parts should be cleaned thoroughly and applied with lubricating paste.
3. The stuffing box and base of gasket should be thoroughly cleaned with care.

4. The gland packing and gasket should be replaced preferably each time the valve is disassembled.
5. To reassemble body and cap, each bolt and nut shall be pre greased and then tightened in accordance with applicable Torque as per Table 1 (see Appendix).
6. After installation of new parts:
Reassemble using reverse order of steps outlined above. Operate valve several times to be assured of smooth operation before reinstalling.

TROUBLESHOOTING

MALFUNCTION	POSSIBLE CAUSE	REMEDIAL ACTION
Valve does not rotate or operate	<ol style="list-style-type: none"> 1. Packing is dropped too tightly. 2. The stem is torn or there is dirt. 3. The times of on-off operation are too many or dirt exists on the surface of the ball. 	<ol style="list-style-type: none"> 1. Loosen nuts and adjust again. 2. Pull apart the valve and clean the dirt.
Ball/Seat Leaking	<ol style="list-style-type: none"> 1. Valve not full closed. 2. Seat or ball damaged 3. Debris trapped in valve. 	<ol style="list-style-type: none"> 1. Close the valve tightly 2. Replace seat or ball. 3. Clean the debris.
Stem Packing Leaking	<ol style="list-style-type: none"> 1. Gland bolts loose. 2. Packing damaged or missing. 3. Seal misaligned 	<ol style="list-style-type: none"> 1. Tighten gland bolts. 2. Replace packing (shut down first). 3. Replace and align it correctly.
Body Gasket Leaking	<ol style="list-style-type: none"> 1. Body bolts loose. 2. Body gasket damaged. 	<ol style="list-style-type: none"> 1. Tighten body bolts. 2. Replace the gasket.



Note

Nylon and Devlon are hard and more scratch resistant compared to Teflon®, and PEEK is harder still. However, Teflon® is more resilient and has better 'memory' in terms of resistance to permanent indentations. All soft seated valves are only suited to clean service applications.

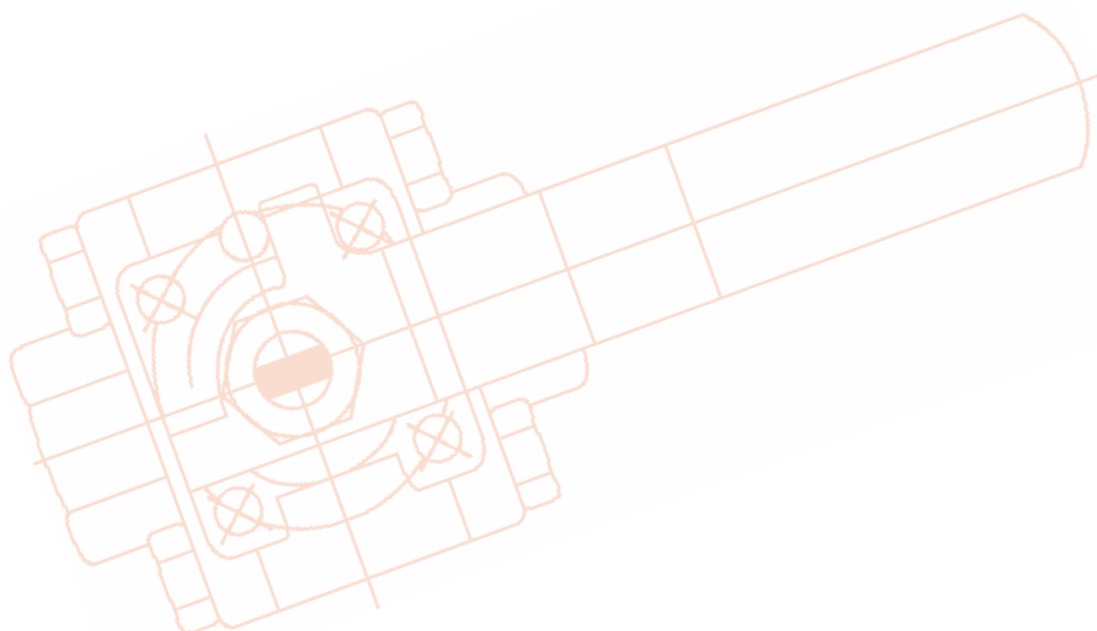

5.0 CONSTRUCTION

BILL OF MATERIALS

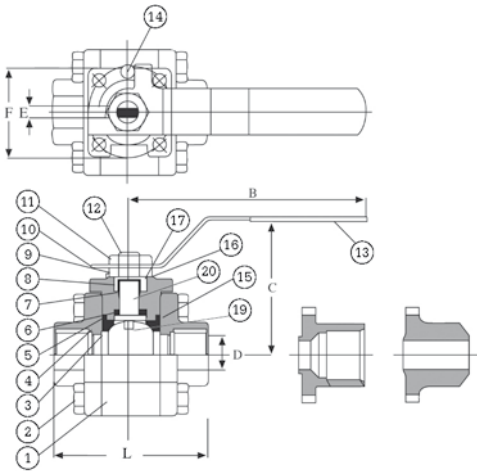

ITEM	DESCRIPTION	SPECIFICATION			
		A351-CF8M/316	A216-WCB/A105	A351-CN7M/A20	A352-LCB/LF2
1	Body	A351-CF8M/316	A216-WCB/A105	A351-CN7M/A20	A352-LCB/LF2
2	Bolt	A193 Gr. B8	A194 Gr. B7	A193 Gr. B8	A320 Gr. L7
3	Seat	RTFE/Nylon	RTFE/Nylon	RTFE/Nylon	RTFE/Nylon
4	End Cap	A351-CF8M/316	A216-WCB/A105	A351-CN7M/A20	A352-LCB/LF2
5	Gasket	PTFE/Graphite	PTFE/Graphite	PTFE/Graphite	PTFE/Graphite
6	Thrust Washer	PTFE	PTFE	PTFE	PTFE
7	Stem Packing	PTFE/Graphite	PTFE/Graphite	PTFE/Graphite	PTFE/Graphite
8	Packing Gland	316	304	A20	A20
9	Gland Nut	SS304	SS304	SS304	SS304
10	Handle	SS	SS/Galv	SS	SS/Galv
11	Stem Nut	SS304	SS304	A20	SS304
12	Stem	A276-316	A276-316	B437-A20	B437-A20
13	Cover	Plastic	Plastic	Plastic	Plastic
14	Stop-Pin	SS304	SS304	A20	SS304
15	Ball	A276-316	A276-316	B437-A20	B437-A20
16	Spring Washer	SS	SS	A20	SS
17	Stop Washer	SS304	SS304	A20	SS304
18*	Locking Device	SS304	SS304	A20	SS304
19†	Anti-Static Device	SS316	SS316	A20	SS304
20†	Stem O-Ring	PTFE/Viton	Viton	PTFE	Viton

* Optional

† Depends on size & class

The above is indicative only. Design varies according to size, class, trim, etc. Refer as-built drawing.

REFERENCED STANDARDS

ANSI/ASME B16.34 - Valve Flanged, Threaded and Welding End

API Spec 6D - Pipeline Valves

API608 - Refinery Ball Valves

BS 5351 - Specification for steel ball valves for the petroleum, petrochemical and allied industries.

API Std 598 - Valve Inspection and Testing

ANSI/ASME B16.5 - Pipe Flanges and Flanged Fittings

APPENDIX A

Bolting Torques

TABLE 1
INDICATIVE* TORQUE VALUES FOR TIGHTENING FLANGE BOLTS Ft Lb (Nm)

Stud Size	Bolting Material			
	B7M/L7M	B7/B16/L7	B8/B8M CL.1	B8/B8M CL.2
3/8 - 16 UNC	15 (20)	20 (27)	15 (20)	20 (27)
7/16 - 14 UNC	25 (34)	30 (41)	22 (30)	25 (34)
1/2 - 13 UNC	40 (54)	50 (68)	35 (47)	45 (61)
9/16 - 12 UNC	55 (75)	70 (95)	55 (75)	65 (88)
5/8 - 11 UNC	75 (102)	100 (136)	70 (95)	85 (115)
3/4 - 10 UNC	135 (183)	170 (231)	125 (170)	150 (203)
7/8 - 9 UNC	200 (271)	270 (366)	170 (230)	200 (271)
1 - 8 UNC	350 (475)	400 (542)	219 (298)	350 (475)

Note:

- (1) Torques shown are for A193 B7/B7M/B8/B8M and A320 L7/L7M/B8/B8M.
- (2) Torque tolerance $\pm 10\%$.
- (3) For temperatures above 750°F (400°C) use 75% of the torque values.
- (4) Above torque values are with the bolts lubricated.
- (5) Values above are based on 30,000 psi (206.85 Mpa) bolting stress and lubricated with heavy graphite and oil mixture or a copper based anti-seize grease.
- (6) Do not exceed by more than 25% of values stated when emergency torquing is required.
- (7) All bolts shall be torqued in the pattern as shown in Table 2 in Appendix to ensure uniform gasket loading.
- (8) Optimum torque can vary depending on type of body gasket but do not increase torque more than 10% above those shown.
- (9) Consult us for other bolt material.
- (10) Most B8M and B8 bolts are class 1 so do not assume class 2 unless you are sure.



Caution

Bolt tensions shown in Table 1 must be decreased by 25% when other or no lubrication used. Non lubricated bolts can have an efficiency of up to 50% less than the torque of values stated.



Caution

Indicative torques shown only, different body gasket systems, different seating styles, different sizes & classes, etc., will have different torque requirements. Furthermore, other stud grades can have much lower torques depending if class 1 or class 2 and or above variables.

APPENDIX A - CONTD.

Stud Lubrication

- Re-tightening of body bolts (with system de-pressurised) and gland packing bolting is permissible, if leakage occurs in these areas.
- Required Torque values are given in Table 1.
- The use of copper-based Anti-seize grease for body and packing stud lubrication and molybdenum disulfide anti-seize grease for stem packing lubrication is recommended.

TABLE 2
BODY BOLT TIGHTENING SEQUENCE

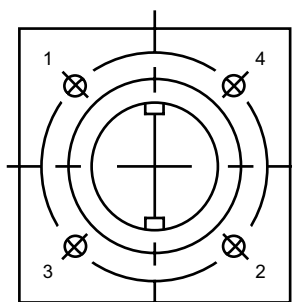

NOTES

A large grid of graph paper for taking notes, consisting of 20 columns and 30 rows of small squares.

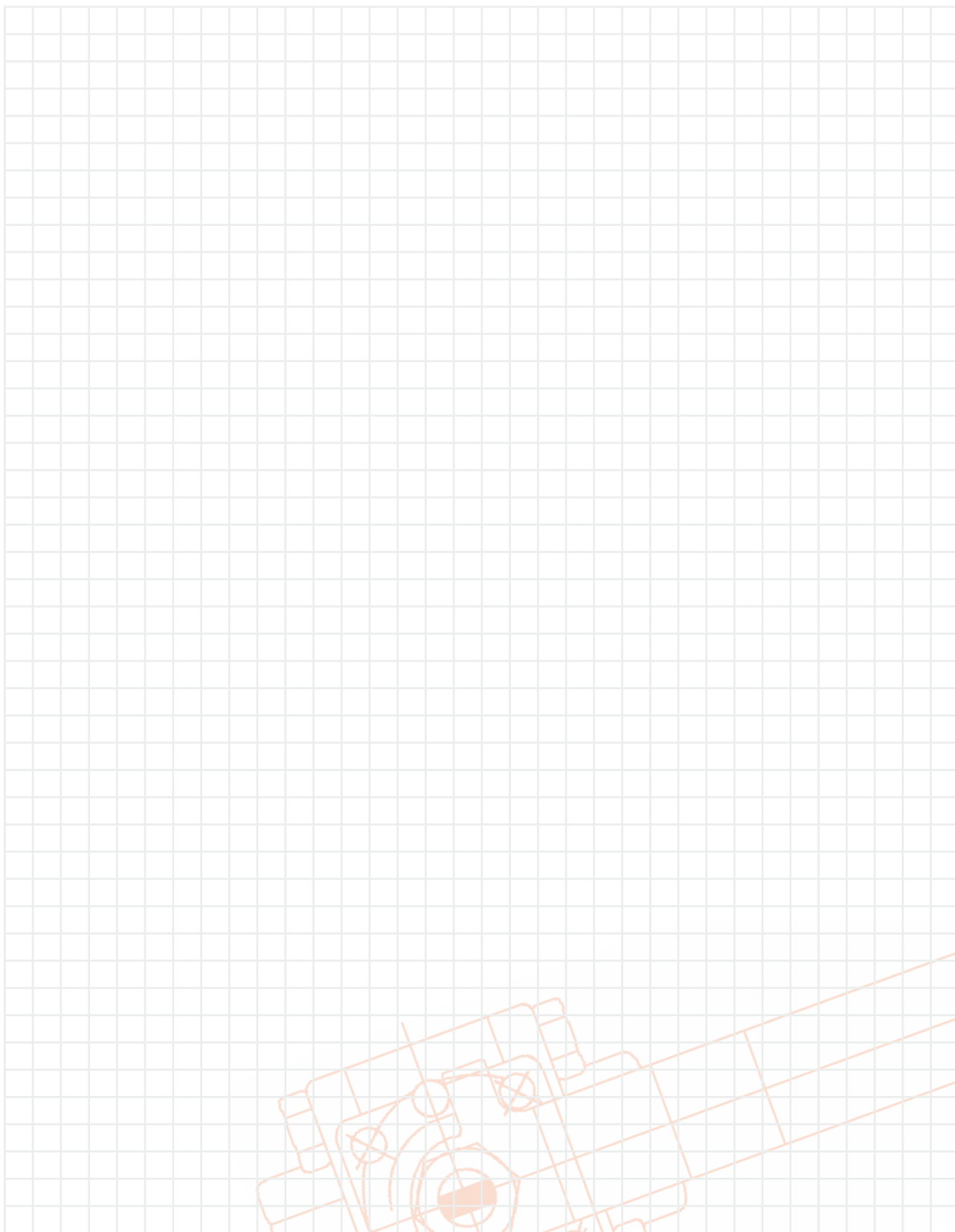

© Copyright Australian Pipeline Valve 1990 - 2021 Edition

Catalogues, photos, brochures and technical publications are the exclusive property of Australian Pipeline Valve. Any unauthorised reproduction in total or in part, shall result in prosecution. Products and data sheets in this publication are subject to change at anytime without notice. Australian Pipeline Valve reserves the right to carry out amendments to products and materials.



APV AUSTRALIAN PIPELINE VALVE®

ADELAIDE • BRISBANE • PERTH



AUSTRALIAN PIPELINE VALVE® HEAD OFFICE
70-78 Stanbel Road Salisbury Plain South Australia 5109 Telephone +61 (0)8 8285 0033 Fax +61 (0)8 8285 0044
email: admin@australianpipelinevalve.com.au

www.australianpipelinevalve.com.au

LOCAL DISTRIBUTOR/AGENT



If you have any requirements in the field of valves, please contact us for a prompt response. Continuous development of Australian Pipeline Valve products may necessitate changes in the design or manufacture process. Australian Pipeline Valve reserves the right to effect any such changes without prior notice.