

GATE, GLOBE & CHECK VALVES-FORGED STEEL

SHORT VERSION

[Click here](#) for complete version of this catalogue



**AUSTRALIAN
PIPELINE VALVE®**

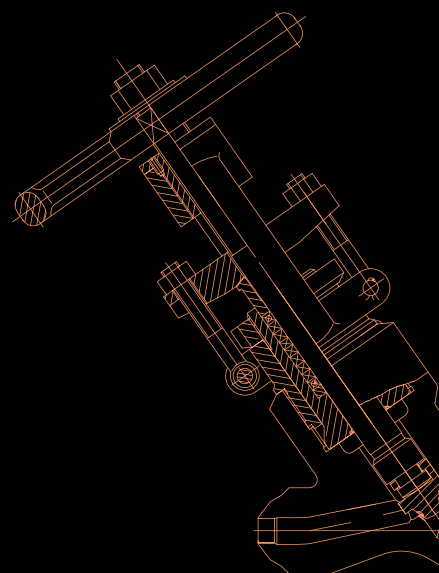

API 607-7th & ISO 10497
Firesafe Certified



ISO 15848-1 Class CO2
Fugitive Emission Certified



QUALITY VALVE MANUFACTURER

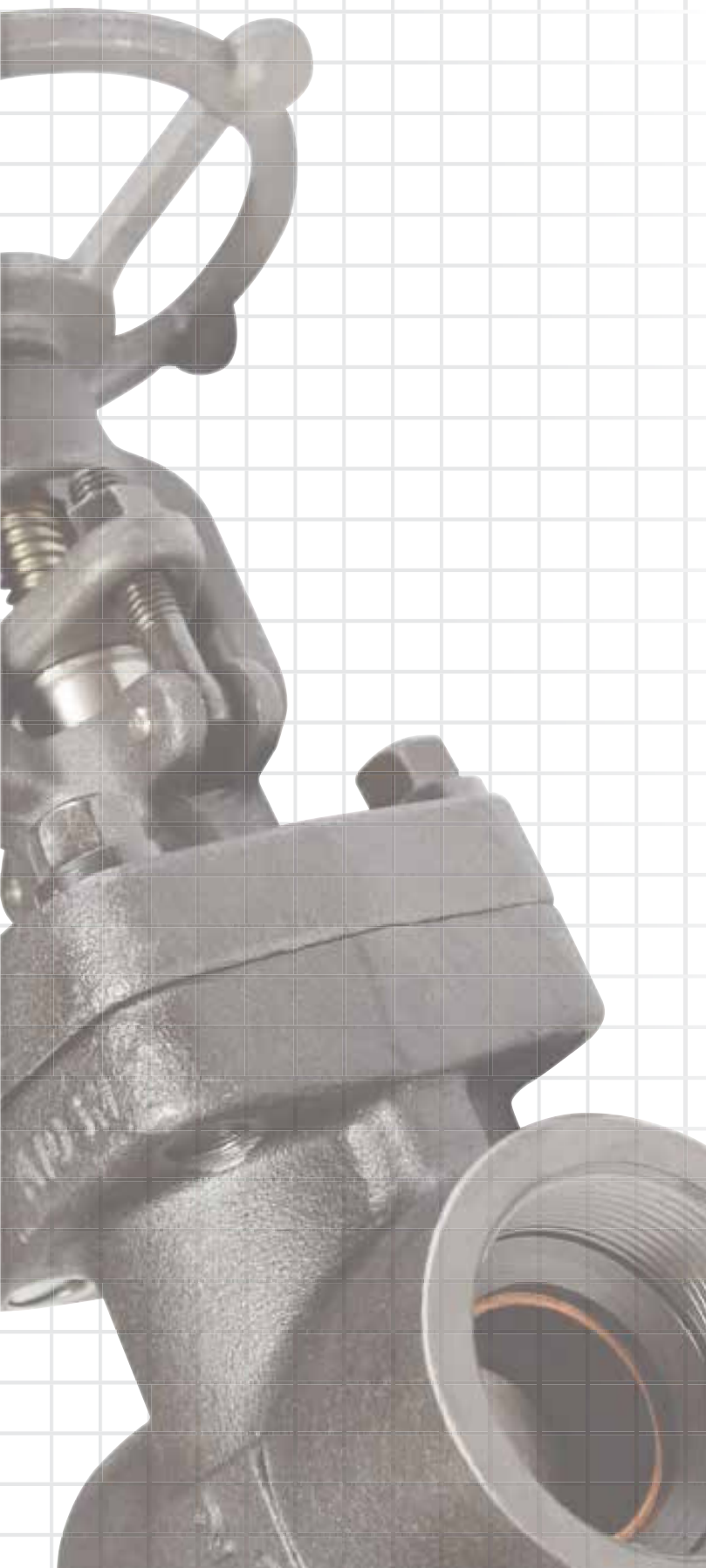

QUALITY COMMITMENT

Quality is Our First Priority.

Consistent product quality and a proven track record makes Australian Pipeline Valve a dependable choice where total reliability is the number one concern.

Since its founding, APV's philosophy has been focused on quality. Our valves are manufactured in full compliance to worldwide standards (such as ASME/ANSI, API, EN, ISO, BS, AS).



**AUSTRALIAN
PIPELINE VALVE®**

70-78 Stanbel Road Salisbury Plain South Australia 5109

Telephone +61 (0)8 8285 0033

email: admin@australianpipelinevalve.com.au

CONTENTS

Figure Number System	4*
Standard Material Specification	5
Options / Accessories	6*
Special Seating / Disc Types & Special Ends	7
Screwed and Weld End Valves	8~20*
High Pressure Gate, Globe, Check Valves	21~25*
Bonnetless Globe Valves	26~27*
Bellow Sealed Valves	28~29
Flanged Gate, Globe & Check Valves	30~35
Parallel Slide Gate Valves	36~39*
Technical Considerations	40*

* This version excludes some of these pages, refer to full version at website.



© Copyright Australian Pipeline Valve 1990 - 2024 Edition

Catalogues, photos, brochures and technical publications are the exclusive property of Australian Pipeline Valve. Any unauthorised reproduction in total or in part, shall result in prosecution. Products and data sheets in this publication are subject to change at anytime without notice. Australian Pipeline Valve reserves the right to carry out amendments to products and materials.

STANDARD MATERIAL SPECIFICATION

Material Part Name	Carbon Steel	Low-Temp Carbon Steel	Alloy Steel	Stainless Steel	Special Alloys
Body Bonnet Cover	A105N	A350/LF2	A182/F1 A182/F5 A182/F9 A182/F11 A182/F22	A182/F304 A182/304L A182/F316 A182/F316L A182/F317 A182/F317L A182/F321 A182/F347	Monel Inconel Hastelloy
Stem Seat Ring *	A276/410 A276/304 A276/316	A276/410 A276/304 A276/316	A276/410 A276/304 A276/316	A276/304 A276/316 A276/321 A276/317 A276/347	Monel Inconel Hastelloy
Wedge / Disc *	A276/410 A276/304 A276/316	A276/410 A276/304 A276/316	A276/410 A276/304 A276/316	A276/304 A276/316 A276/321 A276/317 A276/347	Monel Inconel Hastelloy
Yoke Sleeve Bush	A582-416	A582-416	A582-416	A582-416/Special	A582-416/Special
Gland Flange	A105N	A105N	A105N	A182/F304/Special	A182/F304/Special
Gland Packing	Graphite	Graphite	Graphite	Graphite	Graphite
Bonnet Bolt	A193/B7	A320/L7	A193/B16	A193/B8M	A193/B8M
Gland Bolt	A193/B8	A193/B8	A193/B16	A193/B8M	A193/B8M
Gland Nut	A194/2H	A194/2H	A194/2H	A194/8M	A194/8M
Gland	A276/410	A276/410	A276/410	A276/304/Special	A276/304/Special
Handwheel	Carbon Steel	Carbon Steel	Carbon Steel	Carbon Steel	Carbon Steel/Special
Gasket	A204/304+Graphite A240/316+Graphite	A204/304+Graphite A240/316+Graphite	A204/304+Graphite A240/316+Graphite	A204/304+Graphite A240/316+Graphite	Special
Handwheel Nut	Carbon Steel	Carbon Steel	Carbon Steel	Carbon Steel	Carbon Steel
Name Plate	Aluminium	Aluminium	Aluminium	A240/304	A240/304

* + Stellite hard faced optional

Bolted Bonnet
(Spiral Wound Type)

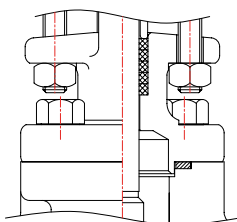

Bolted Bonnet
(Ring Type Joint)

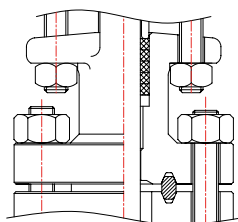

Welded Bonnet
(Full Penetration Welding)

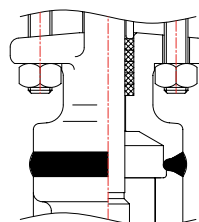

Extended Bonnet
(Full Penetration Welding)

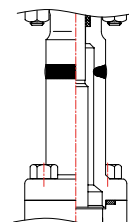

SPECIAL SEATING / DISC TYPES

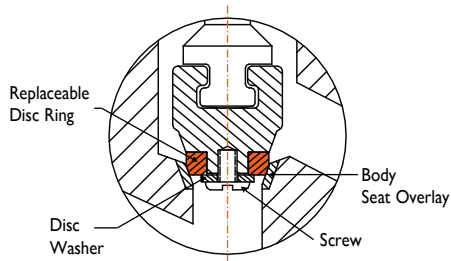

**Elastomeric or Plastic Seat Insert
(Globe Valves)**

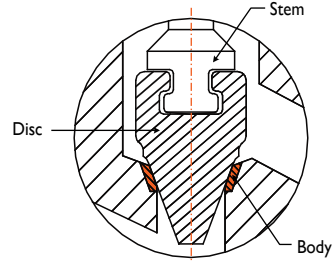

**Needle Point Metering Plug
(Globe Valve)**

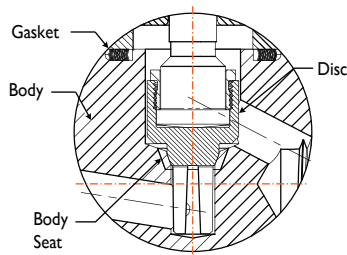

**Flow Control Nozzle
(Globe Valves)**

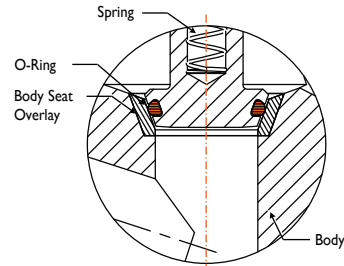

**Elastomeric Seat Insert
(Piston Check Valves)**

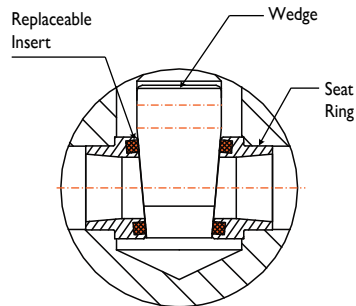

**Elastomeric or Plastic Seat Insert
(Gate Valves)**

SPECIAL ENDS

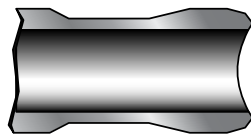

**Integally Reinforced
Contoured End**

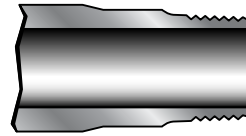

Male Threaded

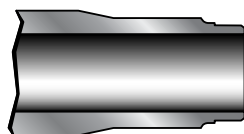

Male Socket Weld

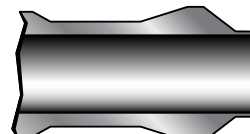

**Integally Reinforced
Lip End**

SCREWED & WELD END GATE VALVES 800 TO 2500 CLASS

FEATURES

Construction	API 602 (ISO 15761) & ASME B16.34
End Connections	Socket Weld - ASME B16.11 Thread - ASME B1.20.1 Butt Weld - ASME B16.25
Inspection & Test	API 598
Stuffing Box Smoothness	≤ Ra 3.2 μm as per API 602
Stem Smoothness	≤ Ra 0.80 μm as per API 602

MATERIALS

No.	Part Name
1	Body
2	Seat Ring
3	Wedge
4	Stem
5	Gasket
6	Bonnet
7	Bonnet Bolt
8	Gland Packing
9	Gland Bolt
10	Gland
11	Gland Flange
12	Gland Nut
13	Thrust Washer
14	Yoke Sleeve
15	Handwheel
16	Name Plate
17	Handwheel Washer
18	Handwheel Nut

BOLTED BONNET

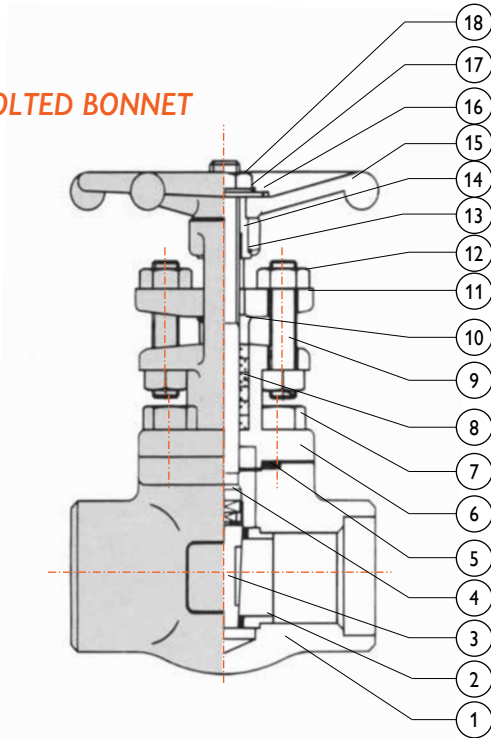

WELDED BONNET

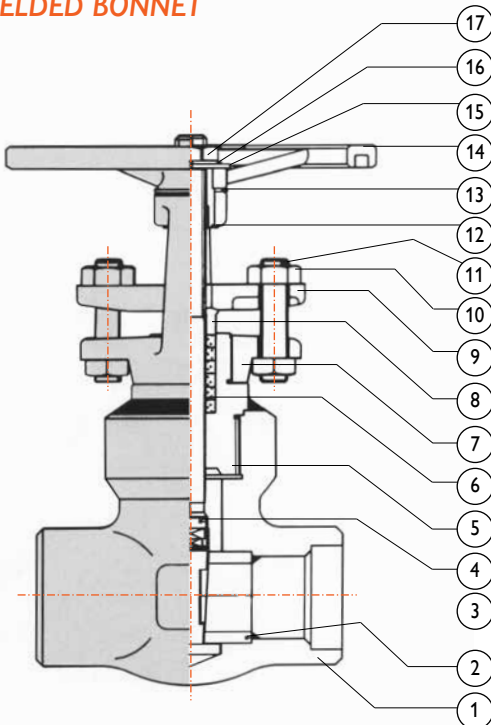

MATERIALS

No.	Part Name
1	Body
2	Seat Ring
3	Wedge
4	Stem
5	Bonnet
6	Gland Packing
7	Yoke
8	Gland
9	Gland Flange
10	Gland Nut
11	Gland Bolt
12	Yoke Sleeve
13	Thrust Washer
14	Handwheel
15	Name Plate
16	Tooth Washer
17	Handwheel Nut

Refer to available range of materials on page 5.
Refer to actual drawing for materials.



API 607-7th & ISO 10497
Firesafe Certified



ISO 15848-1 Class C02
Fugitive Emission Certified

SCREWED & WELD END GATE VALVES 800 TO 2500 CLASS

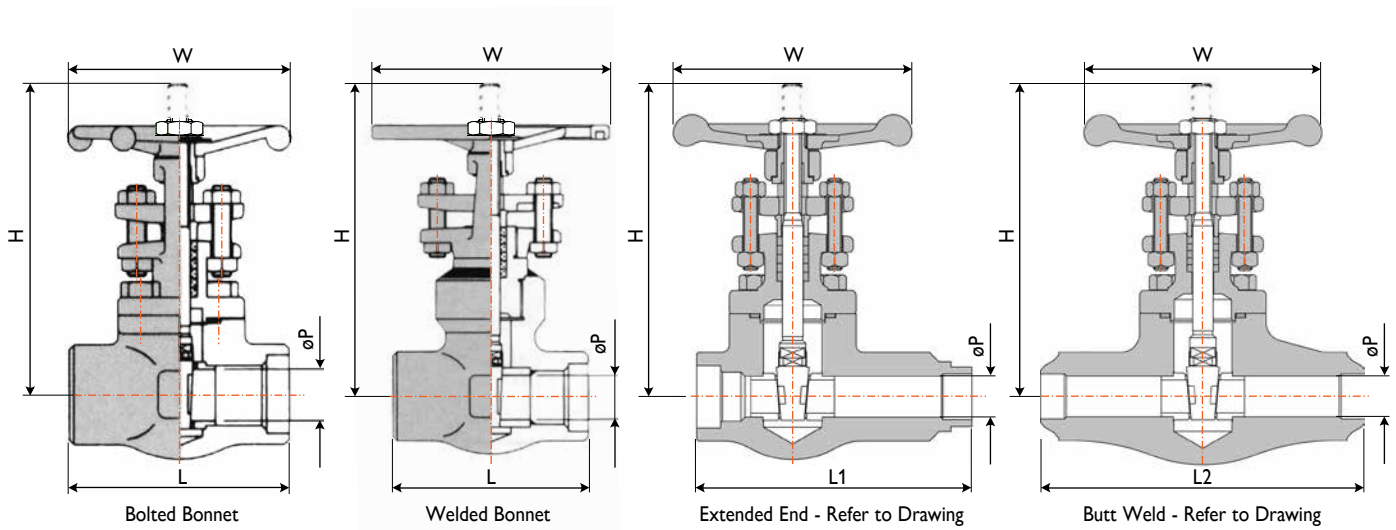

DIMENSIONS BOLTED & WELDED BONNET CLASS 800

Regular Port (in)	1/4"	3/8"	1/2"	3/4"	1"	1-1/4"	1-1/2"	2"	2-1/2"
Full Port (in)	1/4"	3/8"	1/2"	3/4"	1"	1-1/4"	1-1/2"	2"	2-1/2"
L (mm/in)	76.0 / 3.0	76.0 / 3.0	79.0 / 3.11	92.0 / 3.62	111.0 / 4.37	120.0 / 4.72	120.0 / 4.72	140.0 / 5.51	220.0 / 8.66
W (mm/in)	84.0 / 3.3	84.0 / 3.3	100.0 / 3.93	100.0 / 3.93	125.0 / 4.92	160.0 / 5.39	160.0 / 6.3	180.0 / 7.08	200.0 / 7.87
H (mm/in)	144.0 / 5.67	144.0 / 5.67	161.0 / 6.33	163.0 / 6.41	196.0 / 7.72	251.0 / 8.86	251.0 / 9.88	290.0 / 11.4	333.0 / 13.11
P (mm/in)	6.4 / 0.25	9.5 / 0.38	10.5 / 0.41	13.5 / 0.53	17.0 / 0.67	23.5 / 0.93	29.0 / 1.14	36.0 / 1.41	46.5 / 1.83
Wt (kgs/lbs)	1.5 / 3.31	1.5 / 3.31	1.5 / 3.31	2.2 / 4.9	2.8 / 6.4	5.60 / 12.35	5.60 / 12.35	8.5 / 18.74	13.0 / 28.66
Typical Cv Factor	2.0	4.6	5.6	12.0	23.5	48.0	78.0	105.0	200.0

DIMENSIONS BOLTED & WELDED BONNET FULL PORT CLASS 1500

Full Port (in)	1/2"	3/4"	1"	1-1/4"	1-1/2"	2"
L (mm/in)	110.0 / 4.38	127.0 / 5.0	155.0 / 6.13	210.0 / 8.25	210.0 / 8.25	229.0 / 9.0
W (mm/in)	140.0 / 5.5	160.0 / 6.25	200.0 / 7.88	230.0 / 9.07	230.0 / 9.07	250.0 / 9.82
H (mm/in)	224.0 / 7.88	253.0 / 9.94	317.0 / 12.5	337.0 / 14.88	377.0 / 14.88	458.0 / 18.0
P (mm/in)	11.0 / 0.44	16.0 / 0.63	20.0 / 0.82	26.0 / 1.07	32.0 / 1.25	43.0 / 1.69
Wt (kgs/lbs)	5.0 / 11.0	7.0 / 15.4	10.0 / 22.0	18.2 / 40.1	18.0 / 39.7	30.0 / 66.1
Typical Cv Factor	10.6	24.5	38.0	56.0	80.0	197.0

For 'Standard Port' refer to drawing.

DIMENSIONS BOLTED & WELDED BONNET FULL PORT CLASS 2500

Valve Size (in)	1/2"	3/4"	1"	1-1/4"	1-1/2"	2"
L (mm/in)	127.0 / 5.0	155.0 / 6.102	210.0 / 8.267	229.0 / 9.015	229.0 / 9.015	235.0 / 9.251
W (mm/in)	160.0 / 6.299	200.0 / 7.874	230.0 / 9.055	250.0 / 9.84	250.0 / 9.84	300.0 / 11.81
H (mm/in)	253.0 / 9.96	317.0 / 12.48	377.0 / 14.84	458.0 / 18.03	458.0 / 18.03	470.0 / 18.5
P (mm/in)	11.0 / 0.433	16.0 / 0.629	20.0 / 0.787	26.0 / 1.023	28.5 / 1.122	38.1 / 1.69
Wt (kgs/lbs)	8.0 / 17.6	11.0 / 24.2	19.0 / 41.8	34.0 / 74.8	32.0 / 70.4	45.0 / 99.0
Typical Cv Factor	5.6	10.6	24.5	59.8	68.0	95.0

For 'Standard Port' refer to drawing.

Dimensions are indicative and vary according to standard, port design and body material. Refer to as-built drawing.

SCREWED & WELD END GLOBE VALVES 800 TO 2500 CLASS

FEATURES

Construction	API 602, ISO 15761, ASME B16.34
End Connections	Socket Weld - ASME B16.11 Thread - ASME B1.20.1 Butt Weld - ASME B16.25
Inspection & Test	API 598 / BS 5146
Stuffing Box Smoothness	≤ Ra 3.2 μm as per API 602
Stem Smoothness	≤ Ra 0.80 μm as per API 602

BOLTED BONNET

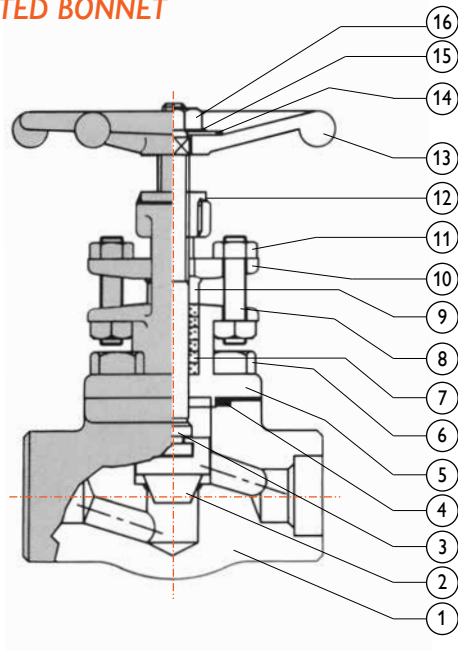

MATERIALS

No.	Part Name
1	Body
2	Disc
3	Stem
4	Gasket
5	Bonnet
6	Bonnet Bolt
7	Gland Packing
8	Gland Bolt
9	Gland
10	Gland Flange
11	Gland Nut
12	Yoke Bush
13	Handwheel
14	Name Plate
15	Handwheel Washer
16	Handwheel Nut

WELDED BONNET

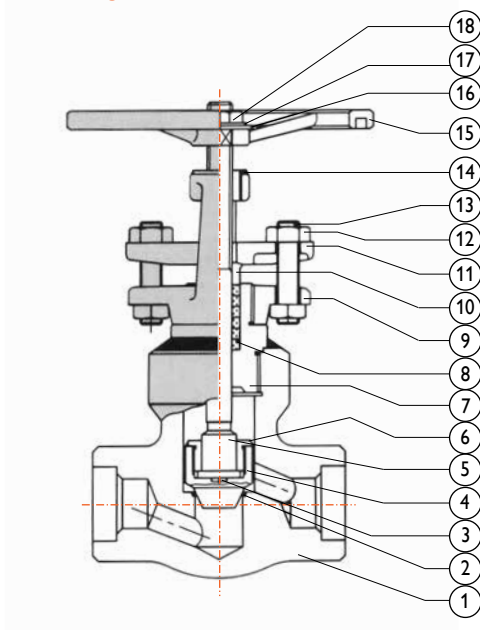

MATERIALS

No.	Part Name
1	Body
2	Seat
3	Pad
4	Disc
5	Stem
6	Disc Nut
7	Bonnet
8	Gland Packing
9	Yoke
10	Gland
11	Gland Flange
12	Gland Nut
13	Gland Bolt
14	Yoke Bush
15	Handwheel
16	Name Plate
17	Tooth Washer
18	Handwheel Nut

Refer to available range of materials on page 5.
Refer to actual drawing for materials.

SCREWED & WELD END GLOBE VALVES 800 TO 2500 CLASS

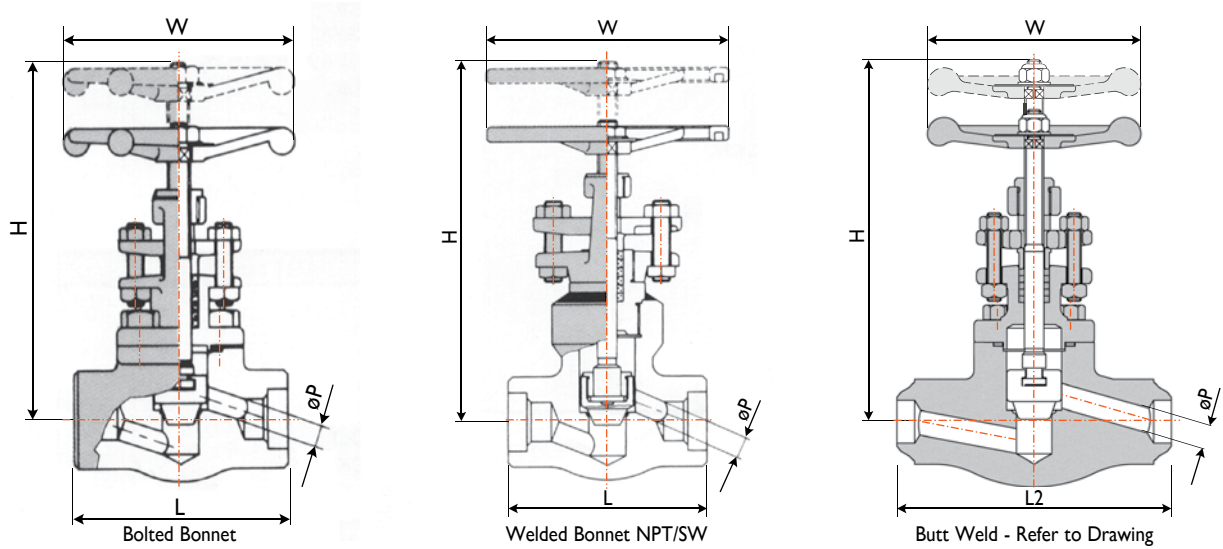

DIMENSIONS BOLTED & WELDED BONNET CLASS 800

Regular Port (in)	1/4"		3/8"		1/2"		3/4"		1"		1-1/4"		1-1/2"		2"		2-1/2"	
Full Port (in)	1/4"		3/8"				1/2"		3/4"		1"		1-1/4"		1-1/2"		2"	
L (mm/in)	76	3.0	76	3.0	76	3.0	92	3.62	104	4.09	120	5.51	152	5.98	172	6.77	220	8.66
W (mm/in)	84	3.3	84	3.3	84	3.3	100	3.94	125	4.92	137	5.39	160	6.30	180	7.08	200	7.87
H (mm/in)	144	5.67	144	5.67	144	5.67	164	6.45	203	7.99	225	8.86	260	10.23	300	11.81	323	12.71
P (mm/in)	6.4	0.25	9.5	0.38	9.5	0.38	12.5	0.5	18.5	0.73	23.5	0.93	23.5	0.93	36	1.41	44	1.73
Wt (kgs/lbs)	1.5	3.31	1.5	3.31	1.5	3.31	2.2	4.9	2.8	6.4	5.60	12.35	5.60	12.35	8.5	18.74	15.0	33.06
Typical Cv Factor	1.0		1.7		1.8		3.6		6.5		11.5		17.0		21.0		35.0	

DIMENSIONS BOLTED & WELDED BONNET FULL PORT CLASS 1500

Valve Size (in)	1/2"		3/4"		1"		1-1/4"		1-1/2"		2"	
L (mm/in)	110	4.38	127	5.0	155	6.13	210	8.25	210	8.25	229	9.0
W (mm/in)	140	5.5	160	6.25	200	7.88	230	9.07	230	9.07	250	9.82
H (mm/in)	230	9.03	261	10.25	314	12.38	377	14.88	377	14.88	459	18.1
P (mm/in)	12	0.44	16	0.63	20	0.82	26	1.07	32	1.26	43	1.69
Wt (kgs/lbs)	5.0	11.0	6.0	13.2	8.0	17.6	15.0	33.1	15.0	33.1	26.0	57.3
Full Port Cv Factor	2.7		5.9		11.2		14.0		19.6		23.3	

For 'Standard Port' refer to drawing.

DIMENSIONS BOLTED & WELDED BONNET FULL PORT CLASS 2500

Valve Size (in)	1/2"		3/4"		1"		1-1/4"		1-1/2"		2"	
L (mm/in)	127	5	155	6.102	210	8.267	229	9.015	229	9.015	235	9.251
W (mm/in)	160	6.299	200	7.874	230	9.055	250	9.842	250	9.842	300	11.81
H (mm/in)	261	10.275	314	12.362	377	14.842	459	18.07	459	18.07	470	18.5
P (mm/in)	11	0.433	13	0.51	18	0.708	23	0.905	26	1.023	35	1.377
Wt (kgs/lbs)	8	17.6	10	22	17	37.4	28	61.6	28.0	61.6	43	94.6
Full Port Cv Factor	2.7		5.9		12.2		14.0		19.6		23.3	

For 'Standard Port' refer to drawing.

Dimensions are indicative and vary according to standard, port design and body material. Refer to as-built drawing.

SCREWED & WELD END Y-TYPE GLOBE VALVES 800 TO 2500 CLASS

FEATURES

Style	Outside Screw & Yoke
Construction	API 602, ISO 15761, ASME B16.34
End Connections	Socket Weld - ANSI/ASME B16.11 Thread - ANSI/ASME B1.20.1 Butt Weld - ANSI/ASME B16.25
Inspection & Test	API 598
Stuffing Box Smoothness	≤ Ra 3.2 μm as per API 602
Stem Smoothness	≤ Ra 0.80 μm as per API 602

BOLTED BONNET

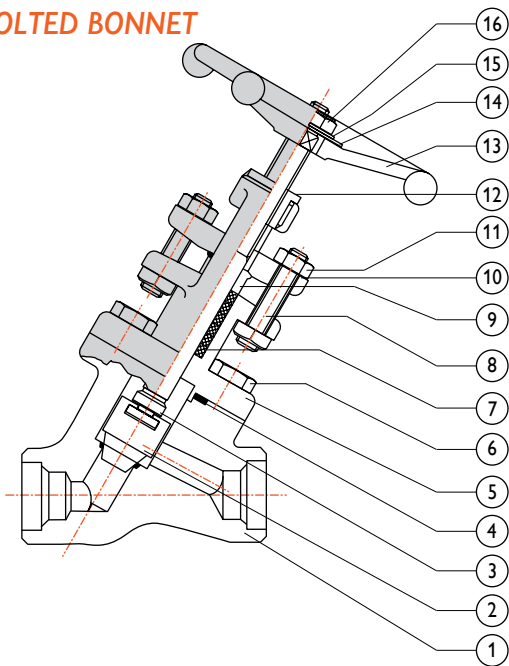

MATERIALS

No.	Part Name
1	Body
2	Disc
3	Stem
4	Gasket
5	Bonnet
6	Bonnet Bolt
7	Gland Packing
8	Gland Bolt
9	Gland Nut
10	Gland Flange
11	Gland Nut
12	Yoke Bush
13	Handwheel
14	Name Plate
15	Handwheel Washer
16	Handwheel Nut

WELDED BONNET

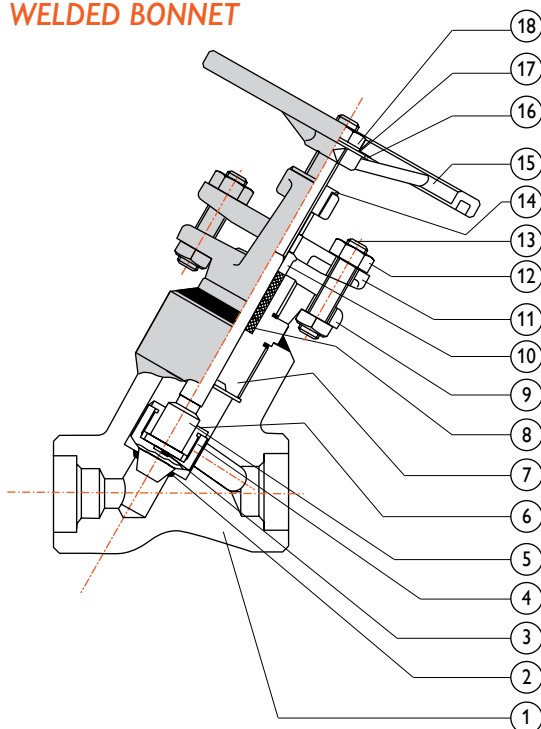

MATERIALS

No.	Part Name
1	Body
2	Seat
3	Pad
4	Disc
5	Stem
6	Disc Nut
7	Bonnet
8	Gland Packing
9	Yoke
10	Gland
11	Gland Flange
12	Gland Nut
13	Gland Bolt
14	Yoke Bush
15	Handwheel
16	Name Plate
17	Tooth Washer
18	Handwheel Nut

Refer to available range of materials on page 5.
Refer to actual drawing for materials.

SCREWED & WELD END Y-TYPE GLOBE VALVES SW, NPT, BW, CLASS 800

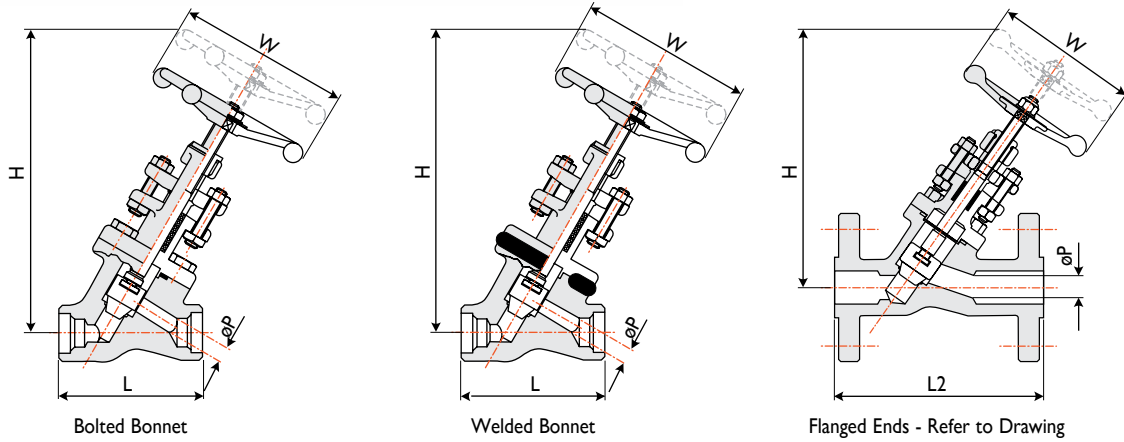

DIMENSIONS BOLTED BONNET CLASS 800

Regular Port Size (in)	1/4"	3/8"	1/2"	3/4"	1"	1-1/4"	1-1/2"	2"	2-1/2"
Full Port Size (in)	1/4"	3/8"	1/2"	3/4"	1"	1-1/4"	1-1/2"	2"	2-1/2"
L (mm/in)	76 / 3.0	76 / 3.0	76 / 3.0	92 / 3.62	104 / 4.02	124 / 4.89	124 / 4.89	152 / 5.99	200 / 7.87
W (mm/in)	84 / 3.3	84 / 3.3	84 / 3.3	97 / 3.82	97 / 3.82	137 / 5.39	137 / 5.39	157 / 6.18	200 / 7.87
H (mm/in)	167 / 6.58	167 / 6.58	167 / 6.58	180 / 7.09	207 / 8.15	225 / 10.04	225 / 10.04	300 / 11.82	352 / 13.85
P (mm/in)	6.4 / 0.25	9.5 / 0.38	9.5 / 0.38	12.5 / 0.5	18.5 / 0.73	23.5 / 0.93	30.5 / 1.20	36.0 / 1.41	45.0 / 1.77
Wt (kgs/lbs)	1.8 / 3.97	1.8 / 3.97	1.8 / 3.97	2.1 / 4.83	3.5 / 7.72	6.70 / 14.8	6.70 / 14.8	9.7 / 21.4	16.0 / 35.27
Typical Cv Factor	2.9	3.9	4.5	5.5	10.0	18.0	29.5	40.0	52.0

80NB ~ 100NB (3" - 4") refer to drawing

DIMENSIONS WELDED BONNET CLASS 800

Regular Port Size (in)	1/4"	3/8"	1/2"	3/4"	1"	1-1/4"	1-1/2"	2"	2-1/2"
Full Port Size (in)	1/4"	3/8"	1/2"	3/4"	1"	1-1/4"	1-1/2"	2"	2-1/2"
L (mm/in)	76 / 3.0	76 / 3.0	76 / 3.0	92 / 3.55	102 / 4.02	124 / 4.89	124 / 4.89	152 / 5.99	200 / 7.87
W (mm/in)	84 / 3.3	84 / 3.3	84 / 3.3	97 / 3.82	97 / 3.82	137 / 5.39	137 / 5.39	157 / 6.18	200 / 7.87
H (mm/in)	167 / 6.58	167 / 6.58	167 / 6.58	180 / 7.09	207 / 8.15	225 / 10.04	225 / 10.04	300 / 11.82	352 / 13.85
P (mm/in)	6.4 / 0.25	9.5 / 0.38	9.5 / 0.38	12.5 / 0.5	18.5 / 0.73	23.5 / 0.93	30.5 / 1.20	36.0 / 1.41	45.0 / 1.77
Wt (kgs/lbs)	1.6 / 3.53	1.6 / 3.53	1.6 / 3.53	1.9 / 4.2	3.2 / 7.1	6.4 / 14.1	6.4 / 14.1	9.3 / 20.5	16.0 / 35.27
Typical Cv Factor	2.9	3.9	4.5	5.5	10.0	18.0	29.5	40.0	52.0

80NB ~ 100NB (3" - 4") refer to drawing

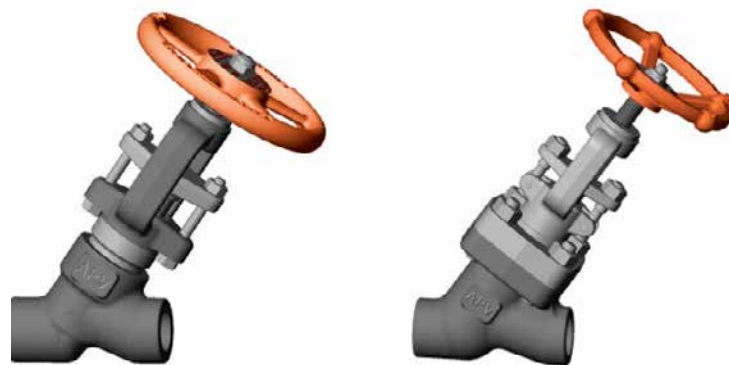

Dimensions are indicative and vary according to standard, port design and body material. Refer to as-built drawing.

SCREWED & WELD END Y-TYPE GLOBE VALVES SW, NPT, BW, CLASS 1500

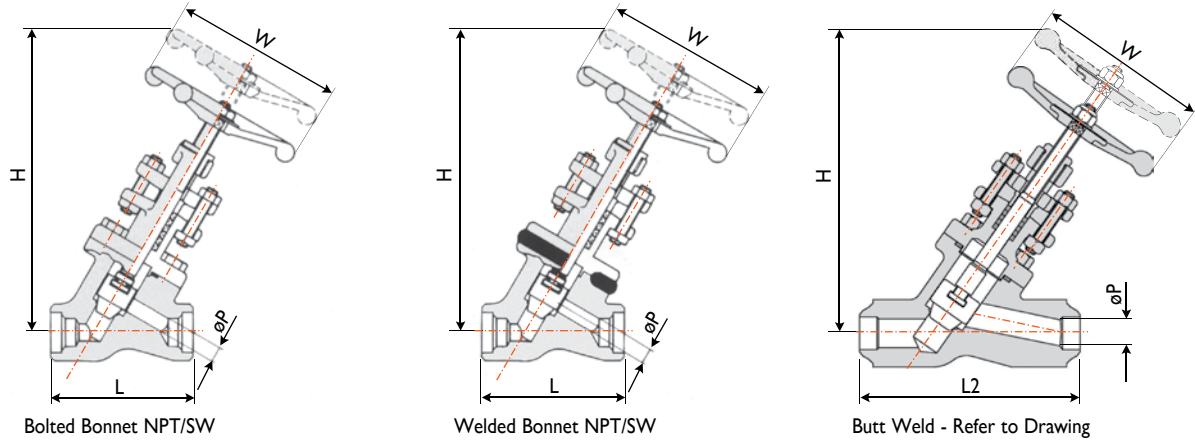

DIMENSIONS BOLTED BONNET CLASS 1500

Std Port Size (in)	1/4"		3/8"		1/2"		3/4"		1"		1-1/4"		1-1/2"		2"	
Full Port Size (in)	1/4"		3/8"				1/2"		3/4"		1"		1-1/4"		1-1/2"	
L (mm/in)	90	3.6	90	3.6	90	3.6	102	4.02	124	4.89	152	5.99	152	5.99	200	7.87
W (mm/in)	97	3.82	97	3.82	97	3.82	97	3.82	137	5.39	157	6.18	157	6.18	157	6.18
H (mm/in)	180	7.09	180	7.09	180	7.09	207	8.15	255	10.04	300	11.82	300	11.82	355	14.0
P (mm/in)	6.4	0.38	9.5	0.38	9.5	0.38	12.5	.5	18.5	0.73	23.5	0.93	30.5	1.2	36.0	1.41
Wt (kgs/lbs)	2.2	4.85	2.2	4.85	2.1	4.63	3.6	7.94	6.8	15.0	9.8	21.6	9.8	21.6	14.3	31.5
Typical Cv Factor	3.5		4.8		4.8		5.5		10.0		18.0		32.5		48.0	

65NB-150NB (2-1/2" ~ 6") refer to drawing

DIMENSIONS WELDED BONNET CLASS 1500

Std Port Size (in)	1/4"		3/8"		1/2"		3/4"		1"		1-1/4"		1-1/2"		2"	
Full Port Size (in)	1/4"		3/8"				1/2"		3/4"		1"		1-1/4"		1-1/2"	
L (mm/in)	90	3.55	90	3.55	90	3.55	102	4.02	124	4.89	152	5.99	152	5.99	200	7.87
W (mm/in)	97	3.82	97	3.82	97	3.82	97	3.82	137	5.39	157	6.18	157	6.18	157	6.18
H (mm/in)	180	7.09	180	7.09	180	7.09	207	8.15	255	10.04	300	11.82	300	11.82	355	14.0
P (mm/in)	6.4	0.38	9.5	0.38	9.5	0.38	12.5	0.5	18.5	0.73	23.5	0.93	30.5	1.2	36.0	1.41
Wt (kgs/lbs)	2.0	4.41	2.0	4.41	1.9	4.2	3.4	7.5	6.6	14.6	9.6	21.2	9.6	21.2	14.1	31.1
Typical Cv Factor	3.5		4.8		4.8		5.5		10.0		18.0		32.5		48.0	

65NB-150NB (2-1/2" ~ 6") refer to drawing

Dimensions are indicative and vary according to standard, port design and body material. Refer to as-built drawing.

SCREWED & WELD END Y-TYPE GLOBE VALVES OUTSIDE SCREW & YOKE/SW, NPT, BW, CLASS 2500/2690*

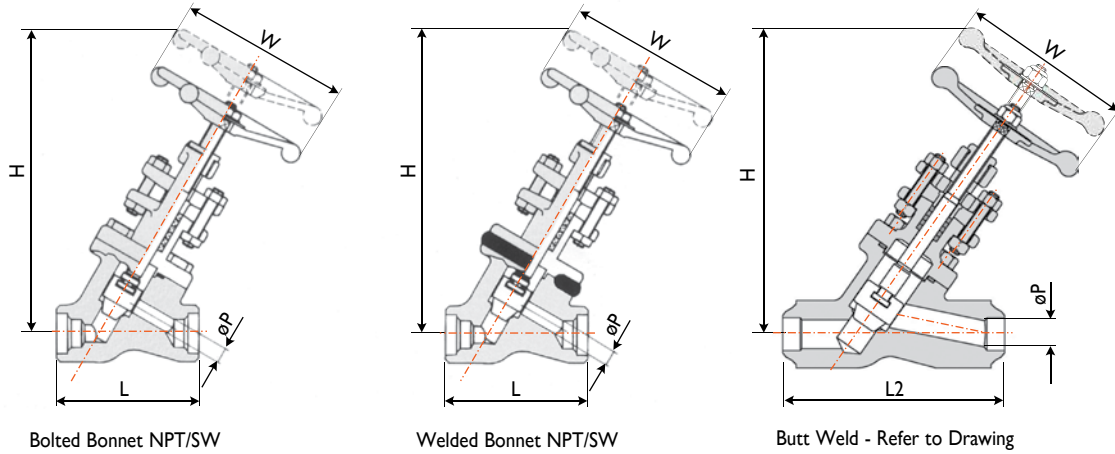

DIMENSIONS BOLTED & WELDED BONNET STANDARD BORE CLASS 2500

Valve Size (in)	1/2"		3/4"		1"		1-1/4"		1-1/2"		2"	
L (mm/in)	115	4.53	130	5.12	150	5.91	220	8.66	220	8.66	260	10.24
W (mm/in)	97	3.82	97	3.82	137	5.39	157	6.18	157	6.18	157	6.18
H (mm/in)	232	9.13	274	10.79	320	12.60	461	18.15	461	18.15	504	19.85
P (mm/in)	9.5	0.38	12.5	0.5	18.5	0.73	235	0.93	30.5	1.20	36.0	1.41
Wt (kgs/lbs)	2.1	4.63	3.6	7.94	6.8	15.0	9.8	21.6	9.8	21.6	14.3	31.5
Typical Cv Factor	5.5		9.5		17.5		27.0		32.5		40.0	

65NB-150NB (2-1/2" ~ 6") *2690 Class refer to drawing.



Dimensions are indicative and vary according to standard, port design and body material. Refer to as-built drawing.

SCREWED & WELD END CHECK VALVES 800 TO 2690 CLASS

DIMENSIONAL DRAWINGS

Piston check bolted bonnet

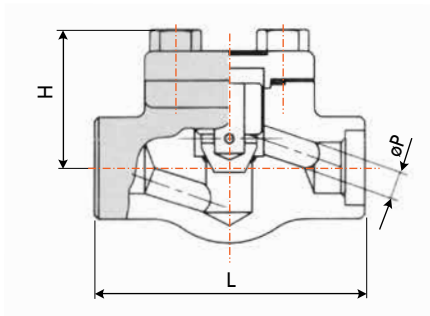

Ball check bolted bonnet

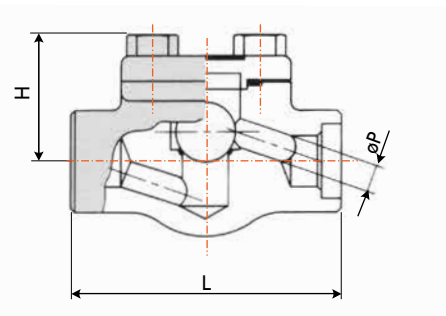

Swing check bolted bonnet

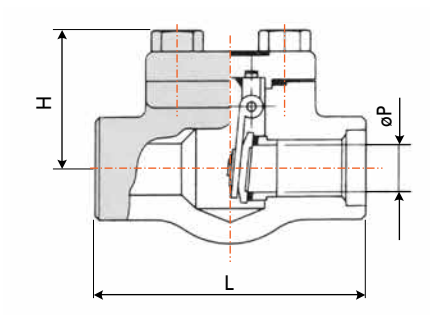

Y-type piston check bolted bonnet

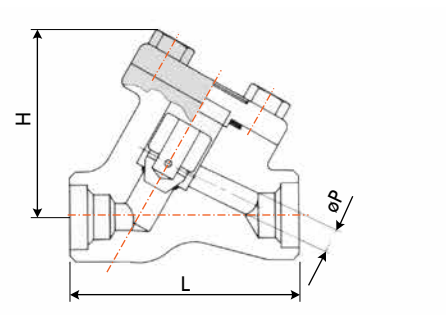

Piston check welded bonnet

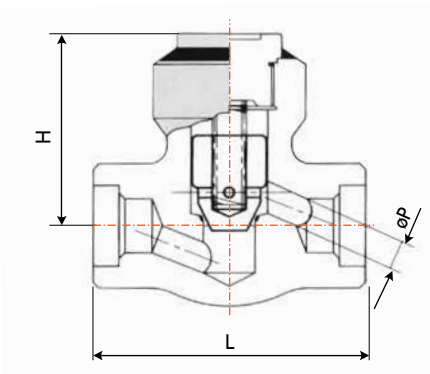

Piston check Y-type welded bonnet

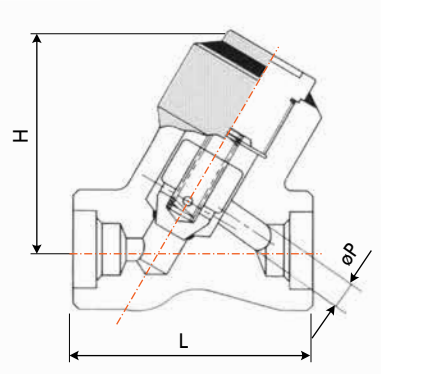

Butt Weld

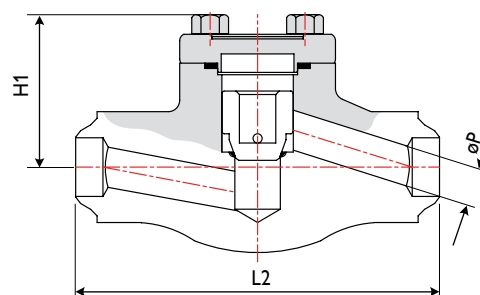

ASME B16.25 - Refer to drawing for dimensions

SCREWED & WELD END CHECK VALVES REGULAR & FULL PORT CLASS 800

DIMENSIONS PISTON CHECK / BALL CHECK

Regular Port (in)	1/4"		3/8"		1/2"		3/4"		1"		1-1/4"		1-1/2"		2"		2-1/2"	
Full Port (in)	1/4"		3/8"		1/2"		3/4"		1"		1-1/4"		1-1/2"		2"		2"	
L (mm/in)	76	3.0	76	3.0	79	3.11	92	3.62	111	4.37	140	5.5	152	5.98	172	6.77	220	8.66
H (mm/in)	46	1.8	46	1.8	46	1.8	61	2.40	78	3.07	75	2.95	84	3.30	118	4.64	140	5.51
P (mm/in)	6.4	0.25	9.5	0.38	9.5	0.38	12.5	0.5	17.5	0.69	23.5	0.93	30	1.18	35	1.37		
Wt (kgs/lbs)	1	2.2	1	2.2	1	2.2	1.5	3.3	2	4.4	4.1	9	4.1	9	6.4	14.2	10.0	0.39
Typical Cv Factor	0.7		1.0		1.2		3.4		6.2		12.9		15.9		18.9		27.0	

80NB~150NB (2-1/2" ~ 6") refer to drawing

DIMENSIONS SWING CHECK

Regular Port (in)	1/4"		3/8"		1/2"		3/4"		1"		1-1/4"		1-1/2"		2"		2-1/2"	
Full Port (in)	1/4"		3/8"		1/2"		3/4"		1"		1-1/4"		1-1/2"		2"		2"	
L (mm/in)	76	3.0	76	3.0	79	3.11	92	3.62	111	4.37	115	4.53	120	4.72	140	5.51	220	8.66
H (mm/in)	46	1.8	46	1.8	46	1.8	61	2.40	78	3.07	75	2.95	84	3.30	120	4.72	140	5.51
P (mm/in)	6.4	0.25	9.5	0.38	10.0	0.39	13.5	0.53	18	0.71	23.5	0.93	30	1.18	36.0	1.41		
Wt (kgs/lbs)	1.0	2.2	1.0	2.2	1.0	2.2	1.5	3.3	2.0	4.4	4.1	9.0	4.1	9.0	6.0	14.2	10.0	0.39
Typical Cv Factor	2.6		3.8		4.0		6.3		13.5		18.3		28.3		53.4		70.0	

80NB~150NB (2-1/2" ~ 6") refer to drawing

DIMENSIONS Y-PISTON

Regular Port (in)	1/4"		3/8"		1/2"		3/4"		1"		1-1/4"		1-1/2"		2"	
Full Port (in)	1/4"		3/8"		1/2"		3/4"		1"		1-1/4"		1-1/2"		1-1/2"	
L (mm/in)	76	3.0	76	3.0	76	3.0	90	3.55	102	4.02	124	4.89	124	4.89	152	5.99
H (mm/in)	67	2.8	67	2.6	67	2.6	77	3.0	80	3.15	111	4.4	111	4.4	138	5.4
P (mm/in)	6.4	0.25	9.5	0.38	9.5	0.38	12.5	0.5	18.5	0.73	23.5	0.93	30.5	1.2	36.0	1.41
Wt (kgs/lbs)	1.2	2.6	1.2	2.6	1.2	2.6	1.4	3.1	2.4	5.3	5.2	11.5	5.2	11.5	7	15.4
Typical Cv Factor	2.8		3.9		3.9		4.8		8.2		13.0		27.0		39.0	

80NB~150NB (2-1/2" ~ 6") refer to drawing

Dimensions are indicative and vary according to standard, port design and body material. Refer to as-built drawing.

SCREWED & WELD END CHECK VALVES STANDARD PORT CLASS 1500

DIMENSIONS PISTON CHECK / BALL CHECK

Std Port (in)	1/4"		3/8"		1/2"		3/4"		1"		1-1/4"		1-1/2"		2"	
L (mm/in)	92	3.62	92	3.62	92	3.62	111	4.37	120	4.72	146	5.74	172	6.77	200	7.87
H (mm/in)	56	2.2	56	2.2	56	2.2	78	3.07	84	3.30	100	3.94	118	4.64	138	5.43
P (mm/in)	6.4	0.25	9.5	0.38	10.5	0.41	13.0	0.51	18.0	0.71	23.5	0.93	25.0	0.98	36.0	1.41
Wt (kgs/lbs)	1.5	3.3	1.5	3.3	1.5	3.3	2.0	4.4	4.1	9	6.4	14.2	6.4	14.2	9.8	21.6
Typical Cv Factor	0.7		1.0		1.2		3.4		6.2		13.9		14.9		18.2	

65NB-150NB (2-1/2" ~ 6") refer to drawing

DIMENSIONS SWING CHECK

Std Port (in)	1/4"		3/8"		1/2"		3/4"		1"		1-1/4"		1-1/2"		2"	
L (mm/in)	92	3.62	92	3.62	92	3.62	111	4.37	120	4.72	146	5.74	140	5.51	178	7.0
H (mm/in)	56	2.2	56	2.2	56	2.2	78	3.07	84	3.30	100	3.94	120	4.72	133	5.23
P (mm/in)	6.4	0.25	9.5	0.38	10	0.39	13	0.51	17.5	0.69	23.5	0.93	28	1.10	36.0	1.41
Wt (kgs/lbs)	1.5	3.3	1.5	3.3	1.5	3.3	2.0	4.4	4.1	9.0	6.4	14.2	6.4	14.2	9.8	21.6
Typical Cv Factor	2.6		4.0		4.0		6.3		13.5		18.3		28.3		53.4	

65NB-150NB (2-1/2" ~ 6") refer to drawing

DIMENSIONS Y-PISTON

Std Port (in)	1/4"		3/8"		1/2"		3/4"		1"		1-1/4"		1-1/2"		2"	
L (mm/in)	90	3.55	90	3.55	90	3.55	102	4.02	124	4.89	152	5.99	152	5.99	200	7.87
H (mm/in)	77	3.0	77	3.0	77	3.0	80	3.15	111	4.4	138	5.4	138	5.4	178	7.0
P (mm/in)	6.4	0.25	9.5	0.38	9.5	0.38	12.5	0.5	18.5	0.3	23.5	0.93	30.5	1.20	36.0	1.41
Wt (kgs/lbs)	1.4	3.1	1.4	3.1	1.4	3.1	2.4	5.3	5.2	11.5	7.0	15.4	7.1	15.4	10.3	22.7
Typical Cv Factor	3.5		3.8		5.0		12.5		18.5		24.9		29.5		36.0	

65NB-150NB (2-1/2" ~ 6") refer to drawing

Dimensions are indicative and vary according to standard, port design and body material. Refer to as-built drawing.

SCREWED & WELD END CHECK VALVES STANDARD PORT CLASS 2500

DIMENSIONS PISTON CHECK / BALL CHECK

Std Port (in)	1/2"		3/4"		1"		1-1/4"		1-1/2"		2"	
L (mm/in)	127	5	155	6.13	210	8.25	229	9	229	9	235	9.25
H (mm/in)	94	3.69	116	4.57	147	5.75	176	6.94	176	6.94	195	7.625
P (mm/in)	11	0.44	13	0.5	18	0.69	23	0.88	26	1	35	1.38
Wt (kgs/lbs)	4.0	8.8	7.0	15.4	14.0	30.9	21.0	46.3	21.0	46.3	30.0	66.2
Typical Cv Factor	1.2		3.4		6.2		9.8		12.9		18.2	

65NB~150NB (2-1/2" ~ 6") refer to drawing. 2690 Class refer to drawing.

DIMENSIONS Y-PISTON CHECK

Std Port (in)	1/2"		3/4"		1"		1-1/4"		1-1/2"		2"	
L (mm/in)	127	5	155	6.13	210	8.25	229	9	229	9	235	9.25
H (mm/in)	94	3.69	116	4.57	147	5.75	176	6.94	176	6.94	195	7.625
P (mm/in)	11	0.44	13	0.5	18	0.69	23	0.88	26	1	35	1.38
Wt (kgs/lbs)	4.0	8.8	7.0	15.4	14.0	30.9	21.0	46.3	21.0	46.3	30.0	66.2
Typical Cv Factor	3.9		5.9		12.9		24.9		29.9		39.0	

65NB~150NB (2-1/2" ~ 6") refer to drawing. 2690 Class refer to drawing.

Dimensions are indicative and vary according to standard, port design and body material. Refer to as-built drawing.

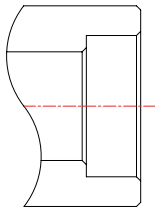

Socket Weld
Design Standard - ASME B16.11

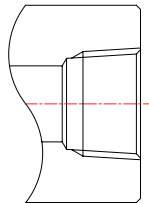

Thread (NPT)
Design Standard - ASME B1.20.1

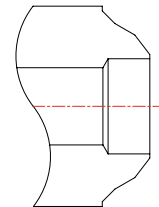

Butt Weld
Design Standard - ASME B16.25



HIGH PRESSURE GATE VALVES SW, NPT, BW CLASS 1500/2500

ASME B16.34 DESIGN



API 607-7th & ISO 10497
Firesafe Certified



ISO 15848-1 Class C02
Fugitive Emission Certified



Seal Welded Bonnet (SWB)

Pressure Sealed Bonnet (PSB)

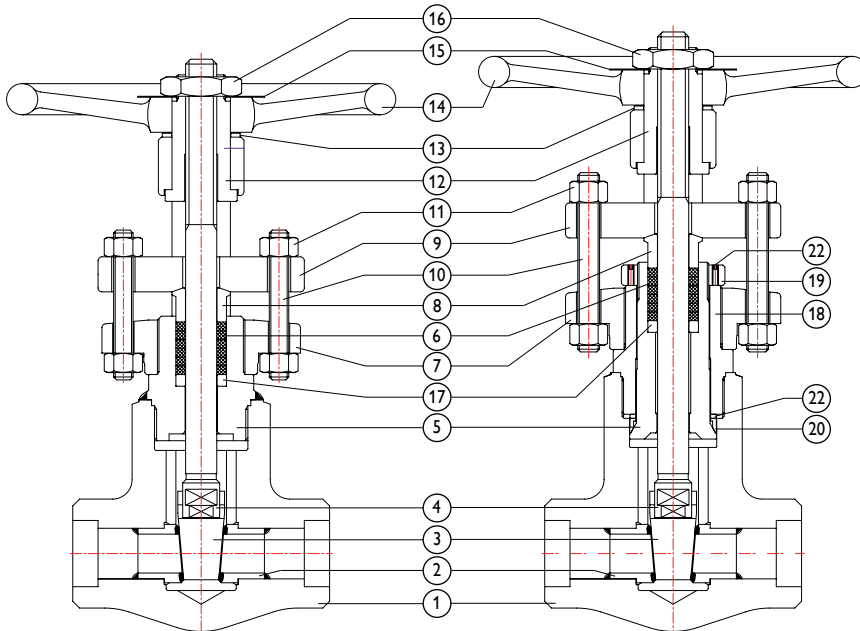

MATERIALS

No.	Part Name
1	Body
2	Seat Ring
3	Wedge
4	Stem*
5	Bonnet
6	Packing**
7	Yoke
8	Gland
9	Gland Flange
10	Gland Bolt
11	Gland Nut
12	Yoke Sleeve
13	Thrust Washer
14	Handwheel
15	Nameplate
16	H/W Nut
17	Packing Washer
18	Bonnet Guide
19	Bonnet Nut
20	Gasket
21	Gasket Retainer
22	Set Screw

* Stem Smoothness $\leq Ra\ 0.80\ \mu m$
** Stuffing Box Finish $\leq Ra\ 3.2\ \mu m$

DIMENSIONS (MM) GATE PSB/SWB, CLASS 1500/2500

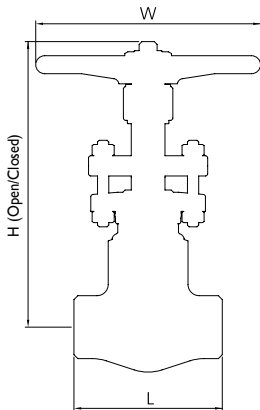

Symbol	Bonnet Joint	Class	1/2" (DN15)	3/4" (DN20)	1" (DN25)	1-1/2" (DN40)	2" (DN50)	2-1/2" (DN65)	3" (DN80)
L (End to end)	SWB /PSB	1500	102	120	132	152	178	254	280
		2500	114	132	152	178	203	254	280
W (Handwheel)		1500	150	170	200	280	320	360	360
		2500	170	200	240	320	360	360	360
P (Port Dia.)		1500	12	16	20	32	40	48	59
		2500	10	13	18	26	35	40	52
H (Height)		1500	216/227	243/256	280/294	366/385	450/473	510/536	510/536
		2500	237/249	275/289	330/347	427/449	497/522	510/536	510/536
Wt (kg)		1500	5.7/6.0	6.8/7.2	8.2/8.7	17.2/18.1	34.0/35.7	38.0/39.9	49.0/51.5
		2500	6.8/7.2	8.2/8.7	17.2/18.1	34.0/35.7	44.5/46.8	52.0/54.6	58.0/60.9

100NB~300NB (4"~12") refer to drawing. 2690 Class refer to drawing.

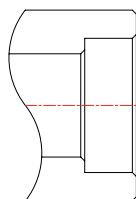

Socket Weld

Design Standard - ASME B16.11

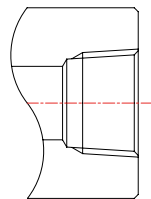

Thread (NPT)

Design Standard - ASME B1.20.1

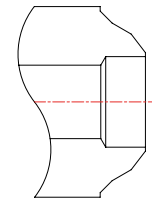

Butt Weld

Design Standard - ASME B16.25

HIGH PRESSURE GLOBE VALVES SW, NPT, BW, CLASS 1500/2500

ASME B16.34 DESIGN

MATERIALS

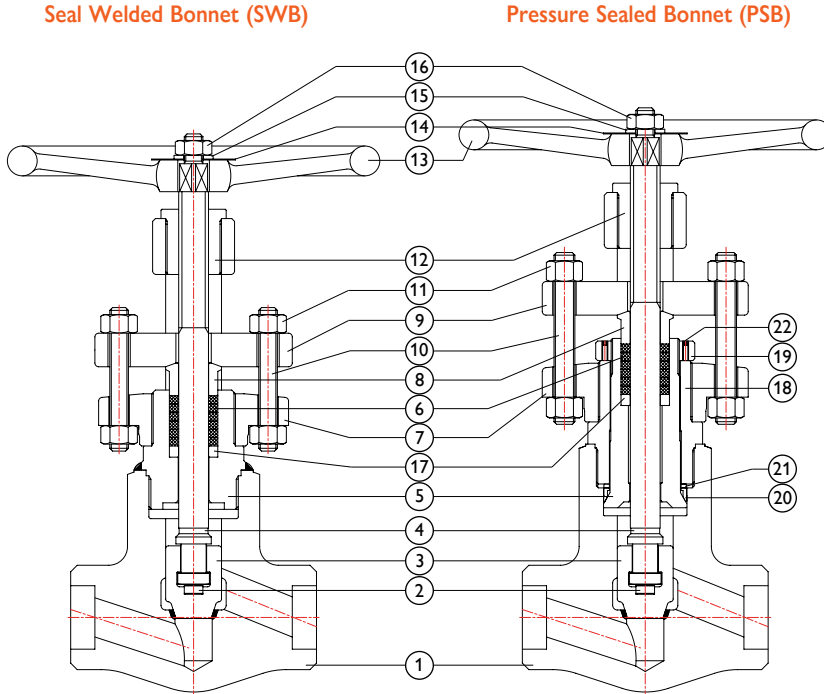

No.	Part Name
1	Body
2	Disc Pad
3	Disc
4	Stem*
5	Bonnet
6	Packing**
7	Yoke
8	Gland
9	Gland Flange
10	Gland Bolt
11	Gland Nut
12	Yoke Bush
13	Handwheel
14	Nameplate
15	H/W Washer
16	H/W Nut
17	Packing Washer
18	Bonnet Guide
19	Bonnet Nut
20	Gasket
21	Gasket Retainer
22	Set Screw

* Stem Smoothness $\leq Ra\ 0.80\ \mu m$

** Stuffing Box Finish $\leq Ra\ 3.2\ \mu m$

DIMENSIONS (MM) GLOBE PSB/SWB CLASS 1500/2500

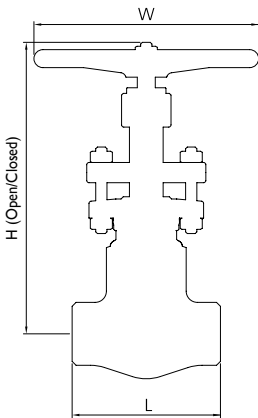

Symbol	Bonnet Joint	Class	1/2" (DN15)	3/4" (DN20)	1" (DN25)	1-1/2" (DN40)	2" (DN50)	2-1/2" (DN65)	3" (DN80)
L (End to end)	SWB /PSB	1500	102	120	132	196	248	254	280
		2500	114	132	152	216	260	254	280
W (Handwheel)		1500	150	170	200	280	320	360	360
		2500	170	200	240	320	360	360	360
P (Port Dia.)		1500	12	16	20	32	40	48	59
		2500	10	13	18	26	35	40	52
H (Height)		1500	212/223	240/252	277/291	372/391	455/478	510/536	510/536
		2500	236/248	276/290	331/348	446/469	513/539	510/536	510/536
Wt (kg)		1500	5.7/6.0	6.8/7.2	8.2/8.7	17.2/18.1	34.0/35.7	38.0/38.9	49.0/51.5
		2500	6.8/7.2	8.2/8.7	17.2/18.1	34.0/35.7	44.5/46.8	52.0/54.6	58.0/60.9

100NB~300NB (4"~12") refer to drawing. 2690 Class refer to drawing.

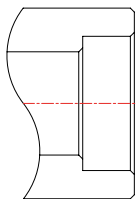

Socket Weld

Design Standard - ASME B16.11

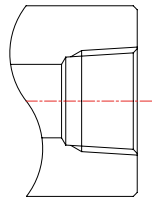

Thread (NPT)

Design Standard - ASME B1.20.1

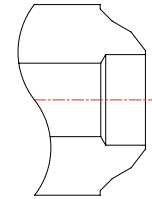

Butt Weld

Design Standard - ASME B16.25

HIGH PRESSURE Y-GLOBE VALVES SW, NPT, BW, CLASS 1500/2500

ASME B16.34 DESIGN

MATERIALS

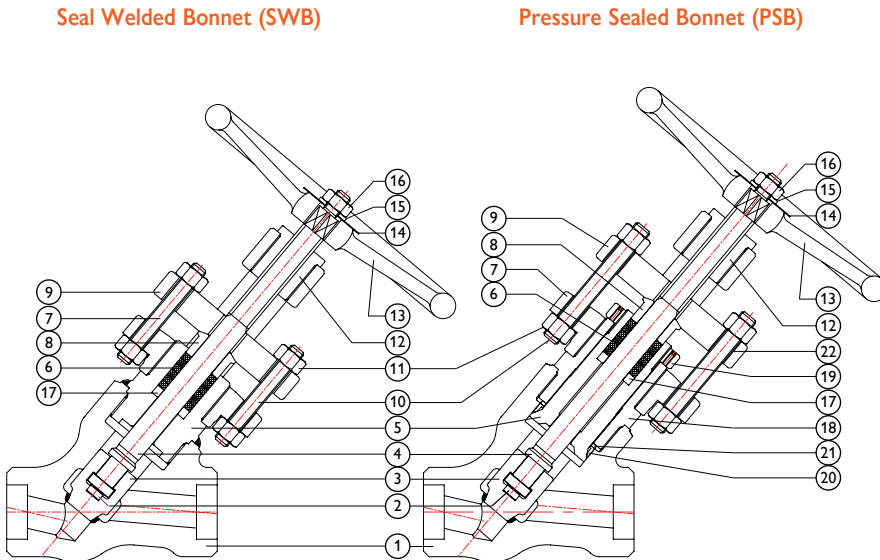

No.	Part Name
1	Body
2	Disc Pad
3	Disc
4	Stem*
5	Bonnet
6	Packing**
7	Yoke
8	Gland
9	Gland Flange
10	Gland Bolt
11	Gland Nut
12	Yoke Bush
13	Handwheel
14	Nameplate
15	H/W Washer
16	H/W Nut
17	Packing Washer
18	Bonnet Guide
19	Bonnet Nut
20	Gasket
21	Gasket Retainer
22	Set Screw

* Stem Smoothness $\leq Ra\ 0.80\ \mu m$
 ** Stuffing Box Finish $\leq Ra\ 3.2\ \mu m$

DIMENSIONS (MM) Y-GLOBE PSB/SWB CLASS 1500/2500

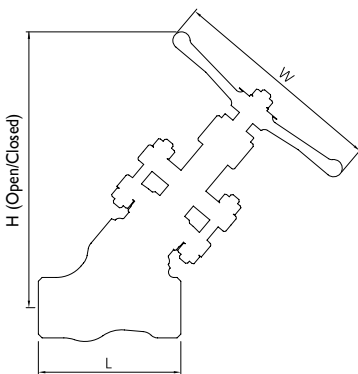

Symbol	Bonnet Joint	Class	1/2" (DN15)	3/4" (DN20)	1" (DN25)	1-1/2" (DN40)	2" (DN50)	2-1/2" (DN65)	3" (DN80)
L (End to end)		1500	102	120	132	196	248	254	280
		2500	114	132	152	216	286	254	280
W (Handwheel)		1500	150	170	200	280	320	360	360
		2500	170	200	240	320	360	360	360
P (Port Dia.)	SWB /PSB	1500	12	16	20	32	40	48	59
		2500	10	13	18	26	35	40	52
H (Height)		1500	208/218	233/245	270/283	366/384	440/462	510/535	510/535
		2500	232/244	270/283	323/339	437/459	498/523	510/535	510/535
Wt (kg)		1500	3.2/3.4	4.1/4.3	6.1/6.4	14.9/15.6	28.5/29.9	38.0/39.9	49.0/51.4
		2500	4.0/4.2	5.0/5.2	10.4/10.9	22.0/23.1	39.5/41.4	52.0/54.6	58.0/60.9

100NB~300NB (4"~12") refer to drawing. 2690 Class refer to drawing.

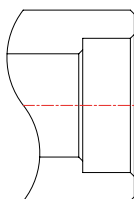

Socket Weld
Design Standard - ASME B16.11

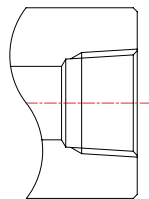

Thread (NPT)
Design Standard - ASME B1.20.1

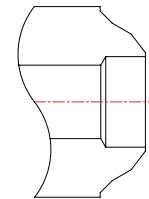

Butt Weld
Design Standard - ASME B16.25

HIGH PRESSURE PISTON CHECK VALVES SW, NPT, BW, CLASS 1500/2500

ASME B16.34 DESIGN

SEAL WELDED COVER (SWC)

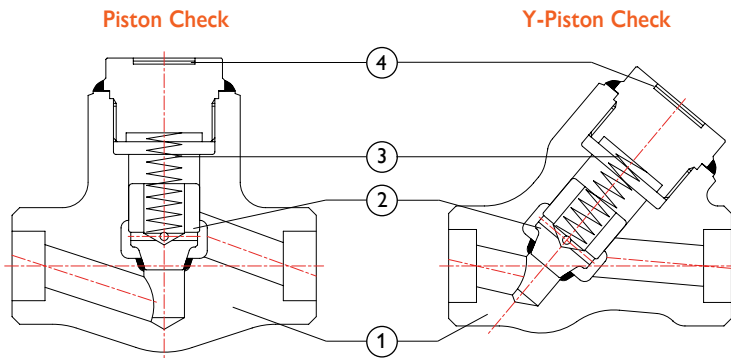

MATERIALS

No.	Part Name
1	Body
2	Disc
3	Spring
4	Bonnet

DIMENSIONS (MM) PISTON CHECK - 1500/2500 CLASS

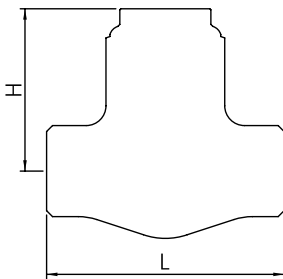

Symbol	Bonnet Joint	Class	1/2" (DN15)	3/4" (DN20)	1" (DN25)	1-1/2" (DN40)	2" (DN50)	2-1/2" (DN65)	3" (DN80)
L (End to end)	SWC	1500	102	120	132	196	248	254	280
		2500	114	132	152	216	260	254	280
P (Port Dia.)		1500	12	16	20	32	40	48	59
		2500	10	13	18	26	35	40	52
H (Height)		1500	73	84	92	130	153	206	235
		2500	82	95	114	149	174	206	235
Wt (kg)		1500	2.4	3.0	4.2	10.5	19.5	28	36.0
		2500	2.8	3.5	7.5	12.5	27.5	30.0	38.0

100NB~300NB (4"~12") refer to drawing. 2690 Class refer to drawing.

DIMENSIONS (MM) Y-PISTON CHECK - 1500/2500 CLASS

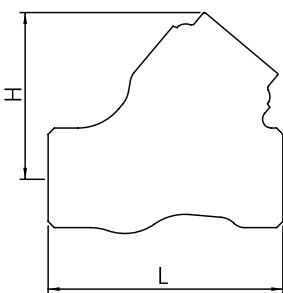

Symbol	Bonnet Joint	Class	1/2" (DN15)	3/4" (DN20)	1" (DN25)	1-1/2" (DN40)	2" (DN50)	2-1/2" (DN65)	3" (DN80)
L (End to end)	SWC	1500	102	120	132	196	248	254	280
		2500	114	132	152	216	286	254	280
P (Port Dia.)		1500	12	16	20	32	40	48	59
		2500	10	13	18	26	35	40	52
H (Height)		1500	70	79	88	119	141	206	235
		2500	80	93	108	146	167	216	235
Wt (kg)		1500	2.4	3.0	4.2	10.5	19.5	28	36.0
		2500	2.8	3.5	7.5	12.5	27.5	30.0	38.0

100NB~300NB (4"~12") refer to drawing. 2690 Class refer to drawing.

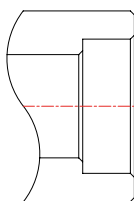

Socket Weld

Design Standard - ASME B16.11

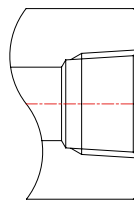

Thread (NPT)

Design Standard - ASME B1.20.1

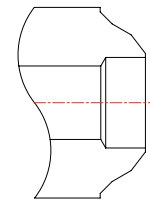

Butt Weld

Design Standard - ASME B16.25

BELLOW SEALED GATE VALVE BOLTED BONNET 800 TO 2500 CLASS

OVERVIEW

Size Range	8NB~50NB (1/4"~ 2")
Rating	150 to 2500 Class
Design	API 602, ISO 15761, ASME B16.34
End Connections	Socket Weld - ASME B16.11 Thread - ASME B1.20.1 or ISO7/1 Butt Weld - ASME B16.25 Flange - ASME B16.5
Test and Inspection	API 598

MATERIALS

No.	Part Name
1	Body
2	Disc
3	Split Ring
5	Gasket
6	Bellows Holder Lower
7	Bonnet Bolt
8	Bellows
9	Stem
10	Bonnet
11	Bonnet Upper
13	Gland Packing
14	Yoke
15	Gland
16	Gland Flange
17	Gland Nut
18	Gland Bolt
19	Thrust Washer
20	Yoke Sleeve
21	Handwheel
22	Handwheel Washer
23	Name Plate
24	Handwheel Nut

* Stem Smoothness ≤ Ra 0.80 μm
 ** Stuffing Box Smoothness ≤ Ra 3.2 μm
 Refer to available range of materials on page 5.
 Refer to actual drawing for materials.

DESIGN FEATURES

- Inconel or 321SS Bellows
 - For longer life
 - Maximum corrosion resistance
- Flanged, screwed or welded end connections
- Welded or bolted bonnet design
- Zero stem leakage
 - Eliminates media loss
 - Satisfies environmental regulations
- Zero maintenance
 - Lower operating costs/no downtime
- Three stem seals for safety
 - Metallic bellows
 - Graphite packing
 - Backseat in open position
- Reduce monitoring costs
- Hardfaced seating surface
 - Stellite 6 for long life
- Additional alloy and trims available
- For applications where leakage into or out of the valve is unacceptable
 - Heat transfer oil
 - Toxic fluids
 - Steam
 - Regulated media

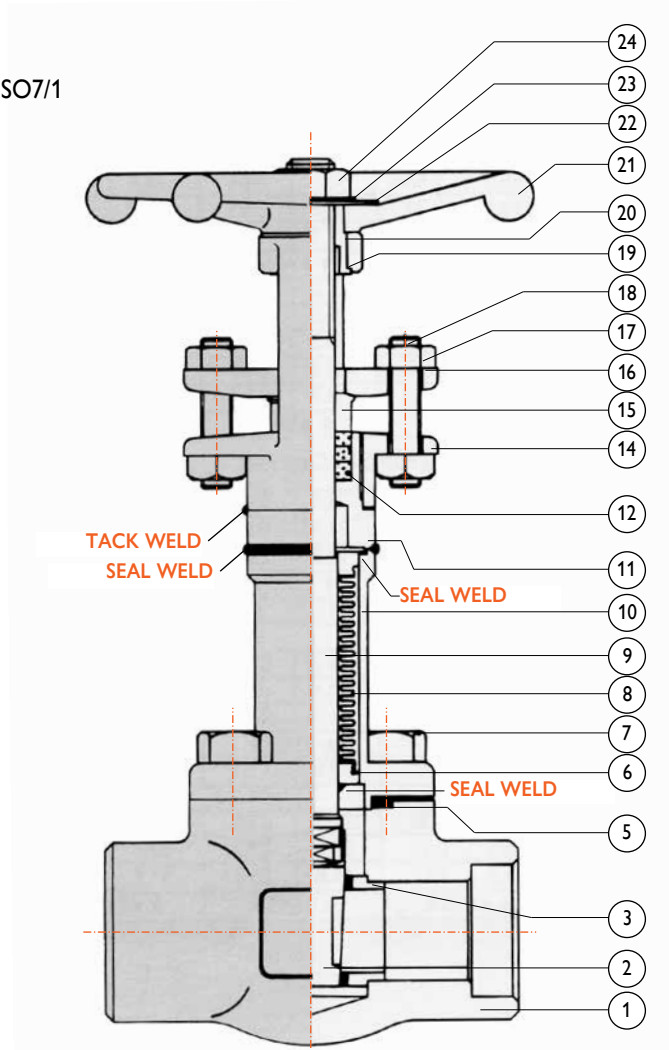

ISO 15848-1 Class CO2
Fugitive Emission Certified

INTEGRAL FLANGED GATE VALVES BOLTED, WELDED & PRESSURE SEAL BONNET CLASS 150 TO 2500

DESIGN FEATURES

- Integral Flanged
- Outside screw
- Bolted bonnet & welded bonnet
- Regular bore & full bore
- Flanging to ANSI B16.5.
- Other flanges available.
- Alternative trim materials available.

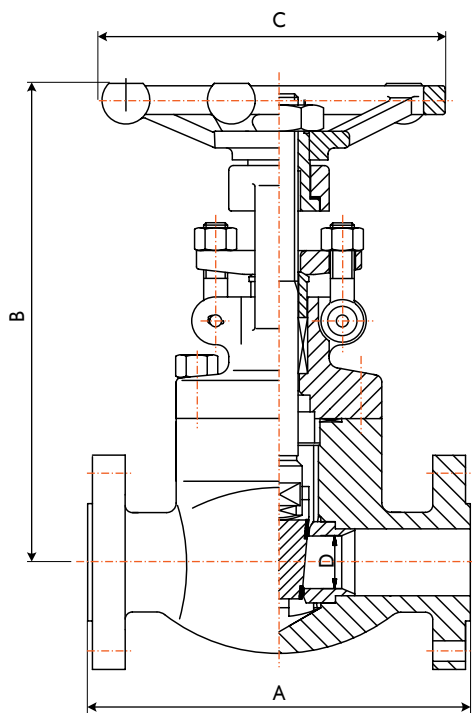

(Welded and Bolted Bonnet)

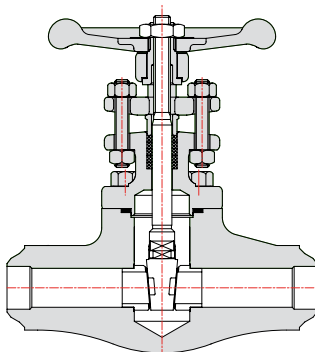

Butt Weld - ASME B16.25
Refer to drawing.

MATERIALS

No.	Part Name
1	Body
2	Disc
3	Stem*
4	Gasket
5	Bonnet
6	Bonnet Bolt
7	Gland Packing**
8	Gland Bolt
9	Gland
10	Gland Flange
11	Gland Nut
12	Yoke Bush
13	Handwheel
14	Name Plate
15	Handwheel Washer
16	Handwheel Nut

* Stem Smoothness \leq Ra 0.80 μ m per API 602
 ** Stuffing Box Finish \leq Ra 3.2 μ m per API 602
 Refer to available range of materials on page 5.
 Refer to actual drawing for materials.

- A = Face to Face
- B = Centre to top
- C = Wheel diameter
- D = Port Diameter



API 607-7th & ISO 10497
Firesafe Certified

ISO 15848-1 Class C02
Fugitive Emission Certified

STANDARDS

- Construction** API 602 & ANSI/ASME B16.34
- End Connections**
 - Socket Weld - ANSI/ASME B16.11
 - Thread - ANSI/ASME B1.20.1
 - Butt Weld - ANSI/ASME B16.25
 - Flanged - ANSI/ASME B16.5
- Inspection & Test** API 598

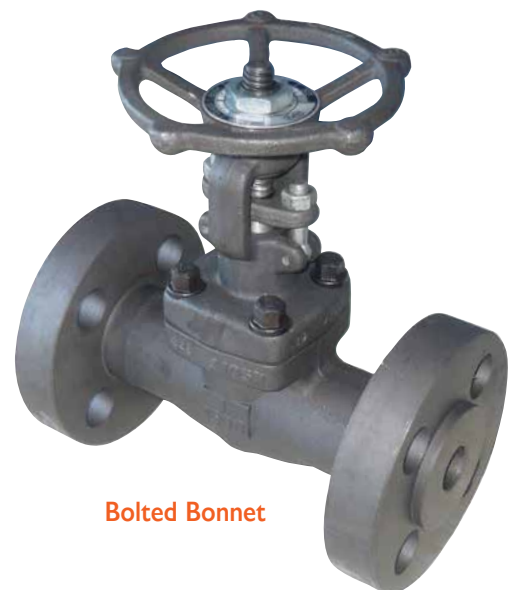

Bolted Bonnet

INTEGRAL FLANGED GATE VALVES

FLANGED DIMENSIONS RF/RTJ - REGULAR BORE*

ANSI Class	Dimensions	1/2"		3/4"		1"		1-1/4"		1-1/2"		2"	
		mm	in	mm	in	mm	in	mm	in	mm	in	mm	in
150	A - Face to Face	108.08	4.25	117.0	4.6	127.0	5.0	140.0	5.5	165.0	6.5	178.0	7.0
	C - Wheel Dia.	84.0	3.31	97.0	3.82	97.0	3.82	137.0	5.69	137.0	5.39	157.0	6.18
	B - Centre to Top	138.0	5.43	147.0	5.79	174.0	6.85	217.0	8.54	217.0	8.54	256.0	10.08
	D - Port Dia.*	9.6	0.38	12.7	0.5	18.5	0.73	24.0	0.95	30.5	1.20	38.1	1.5
	Wt (kg/lb)	2.7	6.6	3.4	7.5	5.0	11.0	9.2	20.3	9.2	20.3	12.7	28.0
300	A - Face to Face	140.0	5.5	152.0	6.0	165.0	6.5	178.0	7.0	190.0	7.5	216.0	8.5
	C - Wheel Dia.	84.0	3.31	97.0	3.82	97.0	3.82	137.0	5.39	137.0	5.69	157.0	6.18
	B - Centre to Top	138.0	5.43	147.0	5.79	174.0	6.85	217.0	8.54	217.0	8.54	256.0	10.08
	D - Port Dia.*	9.6	0.38	12.7	0.5	18.5	0.73	24.0	0.95	30.5	1.20	38.1	1.5
	Wt (kg/lb)	3.0	6.6	3.7	8.16	5.3	11.7	9.5	21.0	9.5	21.0	13.1	28.9
600	A - Face to Face	165.0	6.5	190.0	7.5	216.0	8.5	229.0	9.0	241.0	9.5	292.0	11.5
	C - Wheel Dia.	84.0	3.31	97.0	3.82	97.0	3.82	137.0	5.69	137.0	5.39	157.0	6.18
	B - Centre to Top	138.0	5.43	147.0	5.79	174.0	6.85	217.0	8.54	217.0	8.54	256.0	10.08
	D - Port Dia.*	9.6	0.38	12.7	0.5	18.5	0.73	24.0	0.95	30.5	1.20	38.1	1.5
	Wt (kg/lb)	3.5	7.7	4.9	10.8	6.7	14.8	12.2	26.9	12.4	27.3	16.3	36.4
900 / 1500	A - Face to Face	216.0	8.5	229.0	9.0	254.0	10.0	279.0	11.0	305.0	12.0	368.0	14.5
	C - Wheel Dia.	97.0	3.82	97.0	3.82	137.0	5.40	157.0	6.18	157.0	6.18	157.0	6.18
	B - Centre to Top	147.0	5.79	156.0	6.14	207.0	8.15	246.0	9.69	246.0	9.69	303.0	11.93
	D - Port Dia.*	10.5	0.41	13.0	0.51	18.0	0.71	24.0	0.95	29.0	1.14	36.8	1.45
	Wt (kg/lb)	4.9	10.8	6.9	15.2	18.5	40.8	28.0	61.7	29.0	63.9	34.0	75.0
2500 (Pressure Seal Bonnet)	A - Face to Face	264.0	10.4	273.0	10.74	308.0	12.12	349.0	13.74	387.5	15.25	454.0	17.87
	C - Wheel Dia.	200.0	7.87	200.0	7.87	200.0	7.87	300.0	11.81	300	11.81	300.0	11.81
	B - Centre to Top	321.0	12.63	321.0	12.63	321.0	12.63	389.0	15.31	414.0	16.3	502.0	19.76
	D - Port Dia.*	12.0	0.47	12.7	0.50	18.0	0.70	24.0	0.95	29.0	1.14	36.8	1.45
	Wt (kg/lb)	11.6	25.57	12.3	27.11	20.8	45.85	26.8	59.08	28.4	62.61	40.0	88.18

*Regular bore shown, full port refer to drawing.

CV FACTORS

Class	Size	1/2"	3/4"	1"	1-1/4"	1-1/2"	2"
150~800LB	Typical Cv Factor	3.0	11.3	26.3	52.4	78.0	115.0

Dimensions are indicative and vary according to standard, port design and body material. Refer to as-built drawing.

INTEGRAL FLANGED GLOBE & SDNR VALVES BOLTED, WELDED & PRESSURE SEAL BONNET CLASS 150 TO 2500

DESIGN FEATURES

- Integral flanged.
- Outside screw
- Bolted bonnet & welded bonnet
- Regular bore & full bore
- Flanging to ANSI B16.5
- Other flanges available.
- Alternative trim materials available.

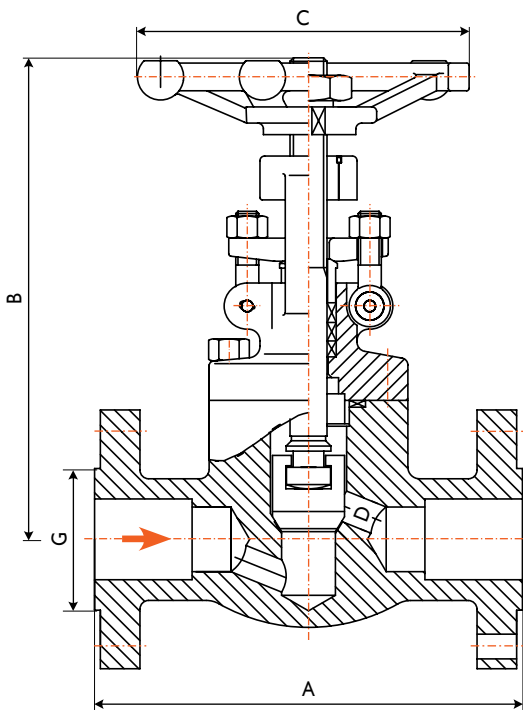

(Welded and Bolted Bonnet)

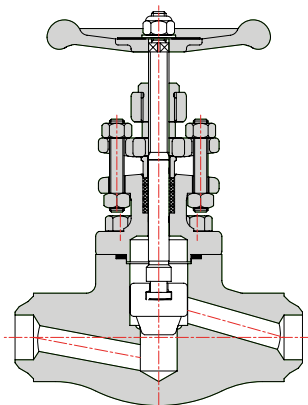

Butt Weld - ASME B16.25
Refer to drawing.

MATERIALS

No.	Part Name
1	Body
2	Disc
3	Stem*
4	Gasket
5	Bonnet
6	Bonnet Bolt
7	Gland Packing**
8	Gland Bolt
9	Gland
10	Gland Flange
11	Gland Nut
12	Yoke Bush
13	Handwheel
14	Name Plate
15	Handwheel Washer
16	Handwheel Nut

* Stem Smoothness $\leq Ra\ 0.80\ \mu m$ per API 602
 ** Stuffing Box Finish $\leq Ra\ 3.2\ \mu m$ per API 602
 Refer to available range of materials on page 5.
 Refer to actual drawing for materials.

- A = Face to Face
- B = Centre to top
- C = Wheel diameter
- D = Port Diameter



API 607-7th & ISO 10497
Firesafe Certified



ISO 15848-1 Class C02
Fugitive Emission Certified



STANDARDS

Construction

API 602, ISO 15761, ASME B16.34

End Connections

- Socket Weld - ANSI/ASME B16.11
- Thread - ANSI/ASME B1.20.1
- Butt Weld - ANSI/ASME B16.25
- Flanged - ANSI/ASME B16.5

Inspection & Test

API 598



Bolted Bonnet

INTEGRAL FLANGED GLOBE VALVES

FLANGED DIMENSIONS RF/RTJ - REGULAR BORE*

ANSI Class	Dimensions	1/2"		3/4"		1"		1-1/4"		1-1/2"		2"	
		mm	in	mm	in	mm	in	mm	in	mm	in	mm	in
150	A - Face to Face	108.08	4.25	117.0	4.6	127.0	5.0	140.0	5.5	165.0	6.5	203.0	8.0
	C - Wheel Dia.	84.0	3.31	97.0	3.82	97.0	3.82	137.0	5.39	137.3	5.39	157.0	6.18
	B - Centre to Top	144.0	5.67	154.0	6.06	177.0	6.97	225.0	8.86	214.0	8.43	254.0	10.0
	D - Port Dia.*	9.5	0.38	12.5	0.5	18.5	0.73	23.5	0.93	30.5	1.20	36.0	1.41
	Wt (kg/lb)	2.8	6.2	3.5	7.72	5.1	11.3	9.3	20.5	9.4	20.68	12.8	28.2
300	A - Face to Face	152.0	6.0	178.0	7.0	203.0	8.0	216.0	8.5	229.0	9.0	267.0	10.5
	C - Wheel Dia.	84.0	3.31	97.0	3.82	97.0	3.82	137.0	5.39	137.0	5.39	157.0	6.18
	B - Centre to Top	144.0	5.67	154.0	6.06	177.0	6.97	225.0	8.86	214.0	8.43	254.0	10.0
	D - Port Dia.*	9.5	0.38	12.5	0.5	18.5	0.73	23.5	0.93	30.5	1.20	36.0	1.41
	Wt (kg/lb)	3.1	6.83	3.8	8.40	5.4	11.9	9.6	21.2	9.6	21.2	13.2	29.1
600	A - Face to Face	165.0	6.5	190.0	7.5	216.0	8.5	229.0	9.0	241.0	9.5	292.0	11.5
	C - Wheel Dia.	84.0	3.31	97.0	3.82	97.0	3.82	137.0	5.39	137.0	5.39	157.0	6.18
	B - Centre to Top	144.0	5.67	154.0	6.06	177.0	6.97	225.0	8.86	214.0	8.43	254.0	10.0
	D - Port Dia.*	9.5	0.38	12.5	0.5	18.5	0.73	23.5	0.93	30.5	1.20	36.0	1.41
	Wt (kg/lb)	3.6	7.94	5.0	11.0	6.8	15.0	12.3	27.1	12.5	27.6	16.6	36.6
900 / 1500	A - Face to Face	216.0	8.5	229.0	9.0	254.0	10.0	279.0	11.0	305.0	12.0	368.0	14.5
	C - Wheel Dia.	97.0	3.82	97.0	3.82	137.0	5.40	157.0	6.18	157.0	6.18	157.0	6.18
	B - Centre to Top	150.0	5.91	179.0	7.05	231.0	9.09	256.0	10.08	256.0	10.08	301.0	11.85
	D - Port Dia.*	9.5	0.38	13.0	0.51	18.0	0.70	24	0.94	29.0	1.14	36.8	1.45
	Wt (kg/lb)	5.0	11.0	7.0	15.4	18.7	41.2	28.2	62.17	29.2	64.37	34.2	75.4
2500 (Pressure Seal Bonnet)	A - Face to Face	264.0	10.39	273.0	10.74	308.0	12.12	349.0	13.74	387.5	15.25	454.0	17.87
	C - Wheel Dia.	200.0	7.87	200.0	7.87	200.0	7.87	300.0	11.81	300.0	11.81	300.0	11.81
	B - Centre to Top	333	13.11	333	13.11	333.0	13.11	408.0	16.06	408.0	16.06	524.0	20.62
	D - Port Dia.*	12.5	0.49	12.5	0.49	18.0	0.70	23.5	0.93	29.0	1.14	35.0	1.37
	Wt (kg/lb)	12.3	27.11	11.6	25.57	20.8	45.85	29.8	65.69	36.4	80.24	43.8	96.56

*Regular bore shown, full port refer to drawing.

CV FACTORS

Class	Size	1/2"	3/4"	1"	1-1/4"	1-1/2"	2"
150~800LB	Typical Cv Factor	2.0	3.0	5.5	11.5	17.0	21.0

Dimensions are indicative and vary according to standard, port design and body material. Refer to as-built drawing.

INTEGRAL FLANGED CHECK VALVES BOLTED, WELDED & PRESSURE SEAL COVER CLASS 150 TO 2500

DESIGN FEATURES

Bolted, welded and pressure seal bonnet.
Integral flanged.
Regular port and full port.
Flanged to ANSI B16.5.
Other flanging available.
Alternative trim materials available.
Spring can be fitted for vertical service to ball and piston type.

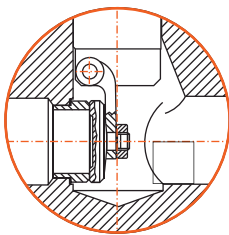
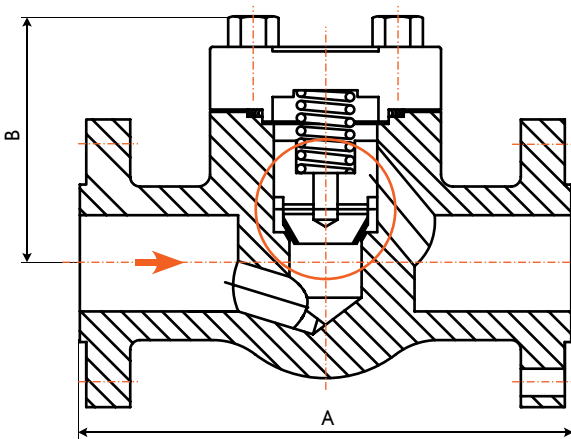

Swing check

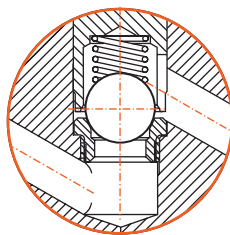

Ball check

MATERIALS

No.	Part Name
1	Body
2	Disc
3	Gasket
4	Cover
5	Cover Bolt
6	Name Plate
7	Ball
8	Seat Ring
9	Disc
10	Retaining Ring
11	Hinge
12	Hinge Pin
13	Support

Refer to available range of materials on page 5.
Refer to actual drawing for materials.

- A = Face to Face
- B = Centre to top
- D = Port Diameter

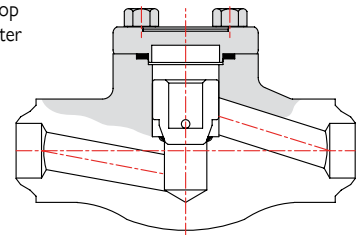

Butt Weld - ASME B16.25
Refer to drawing.

STANDARDS

Construction API 602, ISO 15761, ASME B16.34
End Connections Socket Weld - ANSI/ASME B16.11
 Thread - ANSI/ASME B1.20.1
 Butt Weld - ANSI/ASME B16.25
 Flanged - ANSI/ASME B16.5
Inspection & Test API 598

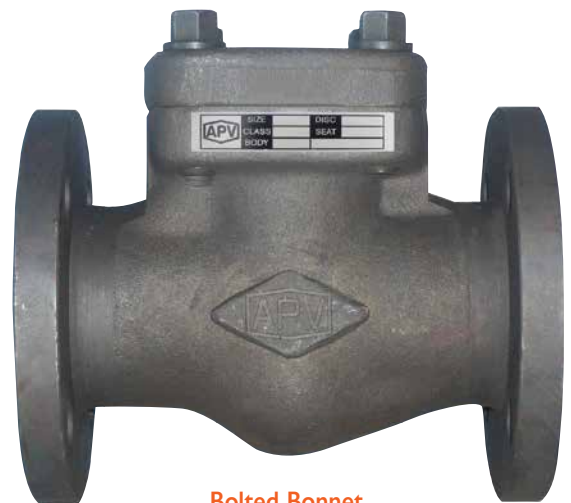

Bolted Bonnet

INTEGRAL FLANGED CHECK VALVES

FLANGED DIMENSIONS - REGULAR BORE*

ANSI Class	Size		1/2"		3/4"		1"		1-1/4"		1-1/2"		2"	
150	A - Face to Face	Piston or Ball	mm	in	mm	in	mm	in	mm	in	mm	in	mm	in
		Swing	Same as Piston or Ball Check Valve											
	B - Centre to Top		46.0	1.81	56.0	2.2	65.5	2.58	74.6	2.94	74.6	2.94	100.5	4.0
	D - Port Dia.*		9.5	0.38	12.5	0.5	18.5	0.73	23.5	0.93	30.5	1.20	36.0	1.41
	Wt (kg/lb)		2.2	4.8	3.0	6.6	4.3	9.5	7.7	17.0	8.3	18.3	13.0	28.7
300	A - Face to Face	Piston, Ball	152.0	60.0	178.0	7.0	203.0	8.0	216.0	8.5	229.0	9.0	267.0	10.5
		Swing	140.0	5.5	152.0	6.0	165.0	6.5	229.0	9.0	241.0	9.5	267.0	10.5
	B - Centre to Top		46.0	1.81	56.0	2.20	65.5	2.58	74.6	2.94	74.6	2.94	100.5	3.96
	D - Port Dia.*		9.5	0.38	12.5	0.5	18.5	0.73	23.5	0.93	30.5	1.20	36.0	1.41
	Wt (kg/lb)		3.3	7.3	5.1	11.2	7.5	16.5	9.9	21.8	13.0	28.7	19.0	41.9
600	A - Face to Face	Piston, Ball	165.0	6.5	190.0	7.5	216.0	8.5	229.0	9.0	241.0	9.5	292.0	11.5
		Swing	Same as Piston and Ball Check Valve											
	B - Centre to Top		46.0	1.81	56.0	2.20	65.5	2.58	74.6	2.94	74.6	2.94	100.5	2.96
	D - Port Dia.*		9.5	0.38	12.5	0.5	18.5	0.73	23.5	0.93	30.5	1.20	36.0	1.41
	Wt (kg/lb)		3.5	7.7	3.9	8.6	5.7	12.6	11.2	24.7	14.0	30.9	18.3	40.3
900/1500	A - Face to Face	Piston, Ball	216.0	8.5	229.0	9.0	254.0	10.0	279.0	11.0	305.0	12.0	368.0	14.5
		Swing	Same as Piston or Ball Check Valve											
	B - Centre to Top		62.0	2.44	68.1	2.68	84.6	3.33	100.5	3.96	102.0	4.02	124.6	4.91
	D - Port Dia.*		9.5	0.38	12.5	0.5	18.5	0.73	23.5	0.93	30.5	1.20	36.0	1.41
	Wt (kg/lb)		6.0	13.2	10.0	22.0	13.5	29.8	14.2	31.3	25.5	56.2	49.0	108.0
2500 (Pressure Seal Bonnet)	A - Face to Face	Piston, Ball	264.0	10.39	273.0	10.74	308.0	12.12			387.5	15.25	454.0	17.87
		Swing	Same as Piston or Ball Check Valve											
	B - Centre to Top		128.0	5.03	130.0	5.11	152.0	5.98	-	-	188.0	7.40	190.0	7.48
	D - Port Dia.*		12.5	0.49	12.5	0.49	18.0	0.71	-	-	29.0	1.14	35.0	1.37
	Wt (kg/lb)		14.3	31.52	16.0	35.27	23.6	52.02	-	-	54.0	119.04	56.0	123.45

* Port diameter shown is for piston and ball check regular port. For swing and for full bore piston and ball check refer to drawing.

CV FACTORS - LIFT CHECK*

Class	Size	1/2"	3/4"	1"	1-1/4"	1-1/2"	2"
150~800LB	Typical Cv Factor	1.0	2.7	5.4	9.5	11.0	18.0

* Reduced Port

CV FACTORS - SWING CHECK*

Class	Size	1/2"	3/4"	1"	1-1/4"	1-1/2"	2"
150~800LB	Typical Cv Factor	6.0	11.3	26.3	63.0	78.0	115.0

* Reduced Port

CV FACTORS - Y-PISTON CHECK*

Class	Size	1/2"	3/4"	1"	1-1/4"	1-1/2"	2"
150~800LB	Typical Cv Factor	4.8	7.8	11.2	18.0	37.0	69.2

* Full Port

PARALLEL SLIDE GATE VALVE CAT P316SF-WF CLASS 150-2500 (15~50NB)

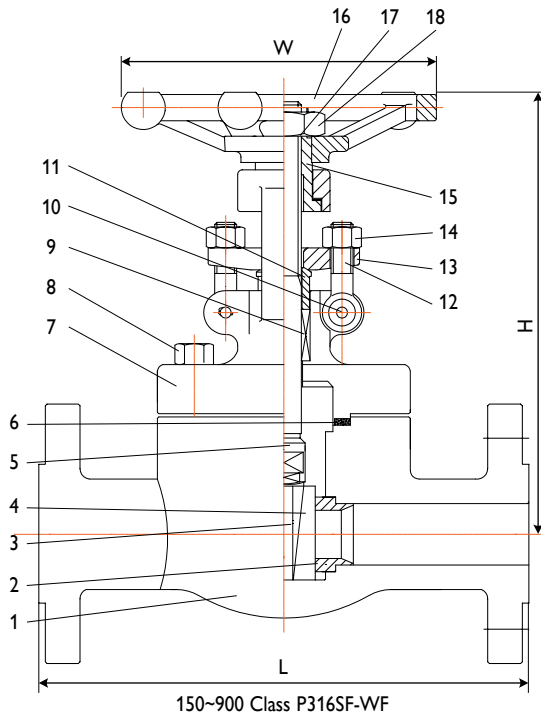

For installation in applications such as industrial, mining and mechanical services. Suitable for super-heated steam, H.T.H.W steam condensate and water.

This design consists of two discs, kept in contact with parallel body seats, using the line pressure and sprung seating action to effect tight closure.

Temperature changes in the line are accommodated by the expanding disc and do not affect the action of the valve. When being opened or closed, the discs slide across the seat faces, dislodging any foreign matter.

The valve operating stem is outside screw rising through the handwheel.

These valves are suitable for full bore steam use, where a low pressure drop across the valve is required. Also suitable for water, oil, gas, etc.

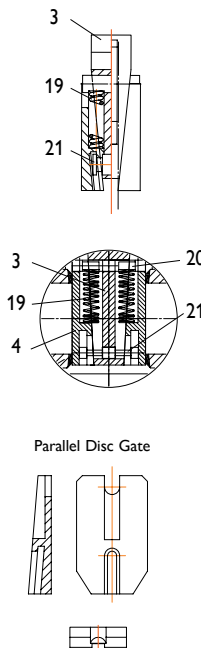

STANDARD MATERIALS 316SF-WF

No.	Part	Material
1	Body	A105N
2	Seat	SS410+ST#6
3	Spreader	SS420
4	Parallel Disc	A182 F6+ST#6
5	Stem*	A182 F6
6	Gasket	SS304+Graphite
7	Bonnet	A105N
8	Bolt	A193 B7
9	Packing**	Graphite
10	Pin	SS410
11	Gland	SS410
12	Gland Eyebolt	A193 B7
13	Gland Flange	A105N
14	Nut	A193 B7
15	Stem Nut	SS410
16	Handwheel	Steel
17	Washer	A3+ZP
18	Nut	A194 2H
19	Springs	Inconel X750
20	Location Pin	A182 F6
21	Connection Pin	A182 F6

Wedge Spreader Rocker Die

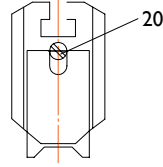
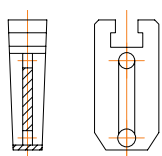

Parallel Disc Gate

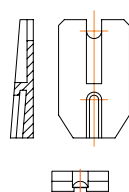

PRESSURE/TEMPERATURE A105N BODY

Class	Cat No.	Test Pressure to API 598 (PSIG)			Working Pressure	
		Shell (Hydro)	Seat (Hydro)	Seat (Air)	CWP WOG	Saturated Steam (at 260°C)*
150 (AS/BST D to F)	150-P316SFXU-S	450	315	80	280	170
300 (AS/BST H to J)	300-P316SFXU-S	1125	815	80	720	600
600	600-P316SFXU-S	2225	1628	80	1440	1200
900	900-P316SFXU-S	3350	2442	80	2190	1800
1500	1500-P136SFXU-S	5626	4078	80	3600	3000

For superheated steam etc. consult chart.
F11, F22, F5 chrome-moly available body for high temperature applications.

TRIM MATERIAL CODES

Seating Code	Body Seat Surface Part No. 3	Double Disc Surface Part No. 4	Stem Part No. 5	Back Seat (Stuffing Box) Part No. 10	Body Material Codes	
					None	A105N
X	F6	F6	F6	F6	0	Special
U	Stellite	Stellite	F6	F6	5	A182 F5/F5a
XU	Stellite	F6	F6	F6	6	A182 F11
P*	F304	F304	F304	F304	8	A182 F304/304L
R*	F316	F316	F316	F316	8M	A182 F316/316L
M*	Monel	Monel	Monel	Monel	9	A182 F22
N*	Alloy 20	Alloy 20	Alloy 20	Alloy 20		
H*	Hastelloy B	Hastelloy B	Hastelloy B	Hastelloy B		

* Add XU modifier to end of model suffix if stellite seat, if stellite seat & disc add U modifier to end.

Contact us for detailed drawing.
* Stem Smoothness ≤ Ra 0.80 μm per API 602
** Stuffing Box Finish ≤ Ra 3.2 μm per API 602

STANDARDS COMPLIANCE

- Basic Design API 600, ANSI B16.34, BS 5157
- Face to Face Dimension ANSI B16.10
- End to End Dimension ANSI B16.10
- Flanged Ends ANSI 16.5
- B.W. Ends ANSI B16.25
- S.W. Ends ANSI B16.11
- Drilling to ANSI or BS/AS 2129 Table D to H or AS 4087 / AS 4331 / ISO 7005-1 PN 10 to 250
- Pressure/Temperature ratings to ANSI B16.5

O.S. & Y. Rising Stem Full Port, Expanded Parallel Slide Gate Valve, Double Disc, Pressure Seal or Bolted Bonnet, Welded-in or Threaded Seat Rings. Mechanically loaded seating for low and high pressure sealing.

Parallel slide dual loaded discs ensure superior shut off and allow by-pass/bleed fitment (double block and bleed requires soft seat inserts).

Pressure/temperature charts available on request.

Available in A105N, F22, F11, F5, 316, 304 etc.



AUSTRALIAN PIPELINE VALVE®

COMPLETE PRODUCT LINE

“Australian Pipeline Valve produces isolation, control and flow reversal protection products for severe and critical service media in utility, steam, pipelines, oil & gas and process industries. APV valves and pipeline products form the most competitive portfolio in the market.”



AUSTRALIAN PIPELINE VALVE BRAND RANGE - CATALOGUES

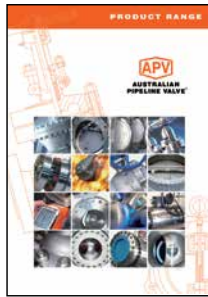

Product Brochure



Ball Valves Floating & Trunnion Mounted

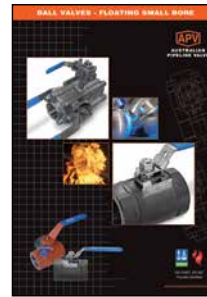

Ball Valves Floating Small Bore

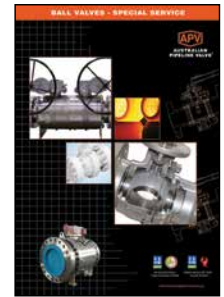

Ball Valves Special Service



Gate, Globe & Check Valves - Cast Steel



Gate, Globe & Check Valves - Forged Steel

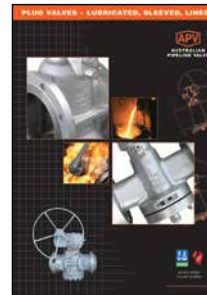

Plug Valves Lubricated, Sleeved & Lined

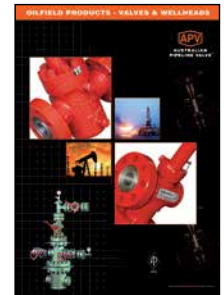

Oilfield Products - Valves & Wellheads

APV FAMILY OF BRANDS RANGE - CATALOGUES



Diamond Gear Gearboxes

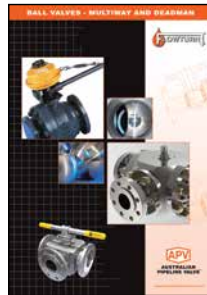

Flowturn Ball Valves Multiway & Deadman



Flowturn Gate, Globe & Check Valves



Flowturn Instrument Valves



Flowturn Strainers & Sight Glasses



Steamco Steam Valves



Supercheck Wafer Check Valves



Superseal Butterfly Valves

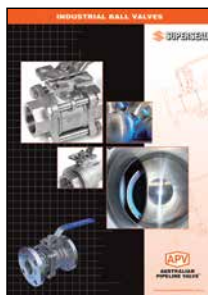

Superseal Industrial Ball Valves



Torqturn Actuators

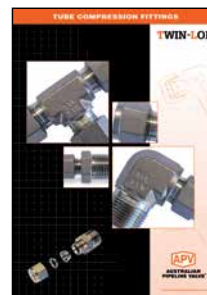

TwinLok Tube Fittings

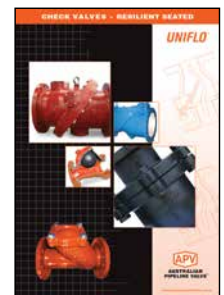

Uniflo Check Valves

Contact us for your local stockist/distributor



AUSTRALIAN PIPELINE VALVE®

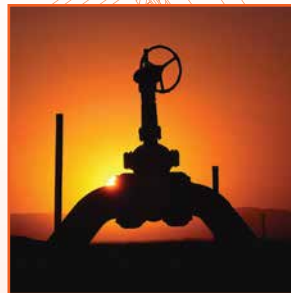

www.australianpipelinevalve.com.au

LOCAL DISTRIBUTOR



QUALITY ASSURANCE AND CERTIFICATION

We are continually improving all facets of quality assurance. Full metallurgical and test certificates are always supplied for all pressure retaining parts, we also provide it on all major trim components.

We have endeavoured to provide a broad outline of our range and capabilities. Because we are continually developing new products for our customers this catalogue will, to some extent be incomplete. This catalogue is a general overview only, individual drawings and data sheets can be furnished on request.

If you have any requirement in the field of valves, please contact us for a prompt response. Continuous development of Australian Pipeline Valve products may necessitate changes in the design or manufacturing processes. Australian Pipeline Valve reserves the right to effect any such changes without prior notice.

