

# DIAPHRAGM, GATE, GLOBE & CHECK VALVES

## SHORT VERSION

[Click here](#) for complete version of this catalogue

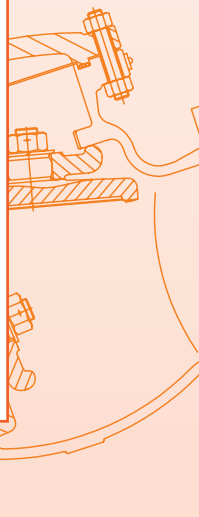
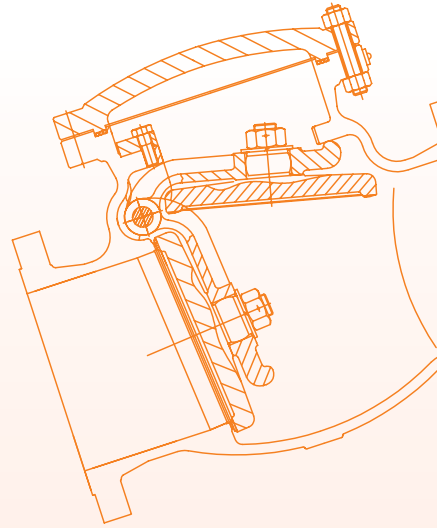
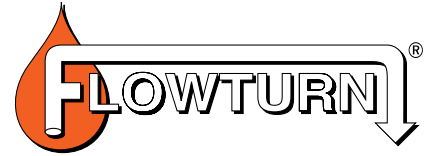

**AUSTRALIAN  
PIPELINE VALVE®**

[www.australianpipelinevalve.com.au](http://www.australianpipelinevalve.com.au)

# QUALITY VALVE MANUFACTURER

## QUALITY COMMITMENT

*Quality is Our First Priority.*

*Consistent product quality and a proven track record makes Australian Pipeline Valve a dependable choice where total reliability is the number one concern.*

*Since its founding, APV's philosophy has been focused on quality. Our valves are manufactured in full compliance to worldwide standards (such as ASME/ANSI, API, EN, ISO, BS, AS).*

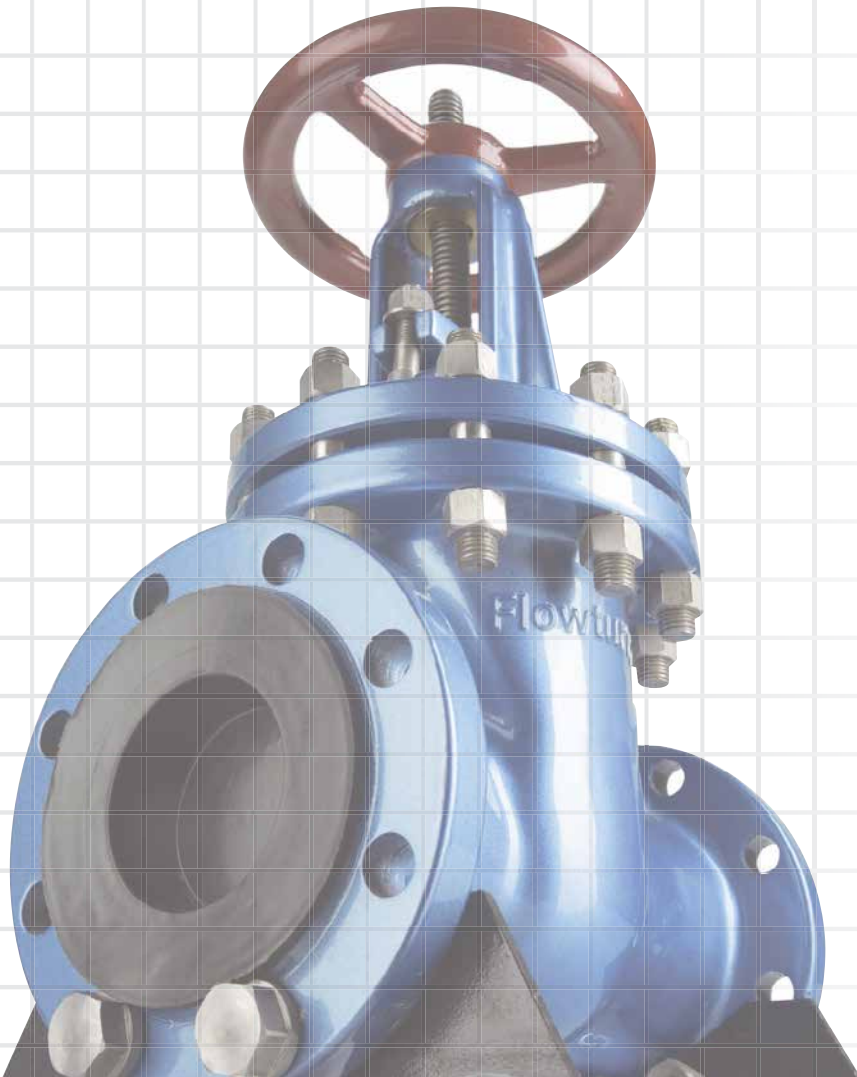

**AUSTRALIAN  
PIPELINE VALVE®**

70-78 Stanbel Road Salisbury Plain South Australia 5109

Telephone +61 (0)8 8285 0033

email: [admin@australianpipelinevalve.com.au](mailto:admin@australianpipelinevalve.com.au)

[www.australianpipelinevalve.com.au](http://www.australianpipelinevalve.com.au)

## CONTENTS

Swing Check Cast Iron - Class 125/250 PN10/16/25 Table D/E/F	4~6*
Swing Check Valve with Lever & Counter-weight	7
Swing Check Valve with Fuseable Link - ESDV	8*
Combination Sight Glass/Check Valve	9*
Uniflo Check Valve (Non-Return) Type APN	10*
Uniflo Check Valve (Non-Return) Type APNX	11
Uniflo Tilt Type Check Valve - 500 Series	2~13*
Uniflo Tilt Type Check Valve Rubber Coated Disc - SC Series	14*
Uniflo Tilt Type Check Valve Metal Seated - SC-VAL Series	15*
Uniflo Ball Check Valve - BC Series	17*
Supercheck Wafer Check Valve - ASG Series	18*
Gate Cast Iron - Class 125/250, PN16, PN25 Table D/E/F	19~22*
Globe Cast Iron - Class 125/250, PN16, PN25 Table D/E/F	23~24*
Right Angle Globe Valve Cast Iron	25
Swing Check, Globe and Wedge Gate Valve Stainless Steel	26~28*
Diaphragm Valve Weir APA & Straight Through APKB	29~31*
Sluice Gate Valve Resilient Seat	32~41*
Knife Gate Valve - ADC Series	42~53*
Knife Gate Valve - DCNP Series	54~57*
Knife Gate Valve Actuator - DCNP/DCNP-B Series	58
Knife Gate Valve - DCNP-b Series	59~63*
Slurry Knife Gate Valve - DK Series	64~69*
Slurry Knife Gate Valve - DT Series	70~78*
Knife Gate Valve - Part Number System	79*
Pinch Valve	80*
Y Type Strainer SLCI-8111 Series	81~84*
Basket Strainer	85~86*
Extended Handwheel - Model LX	87*
Technical Considerations	88*

\* This version excludes some of these pages, refer to full version at website.



© Copyright Australian Pipeline Valve 1990 - 2024 Edition

Catalogues, photos, brochures and technical publications are the exclusive property of Australian Pipeline Valve. Any unauthorised reproduction in total or in part, shall result in prosecution. Products and data sheets in this publication are subject to change at anytime without notice. Australian Pipeline Valve reserves the right to carry out amendments to products and materials.

# SWING CHECK VALVE CAST IRON BODY PN10~35, ANSI CLASS 125/250 • SL404

- Table D - SL404-D
- Table E - SL404-E
- Table F - SL404-F
- PN10 - SL404-10
- PN14 - SL404-14
- PN16 - SL404-16
- PN21 - SL404-21
- PN35 - SL404-35
- 125 Class SL404-125
- 150 Class SL404-150
- 250 Class SL404-250



**Design**

BSEN 12334 (BS 5153), MSS-SP71 Type 1

**Flanging/Pressure Class**

- ANSI B16.1 125lb, 150lb, 250lb.
- ANSI B16.42 150lb, 250lb.
- AS 2129 table D, E, F, H.
- AS 4087 PN14, PN16, PN21, PN35.
- ISO 7005-1, PN10, PN16, PN25.
- AS 4331.1 PN10, PN16, PN25.
- EN 1092-2 PN10, PN16.

**Face to Face Dimensions**

ASME B16.10, EN 558-1 Series 10, EN 12334 (BS 5153)  
(AS 4794 on request)

**Test Standard**

AS 4794, EN 12266-1, MSS-SP71, ISO 5208, API 598.

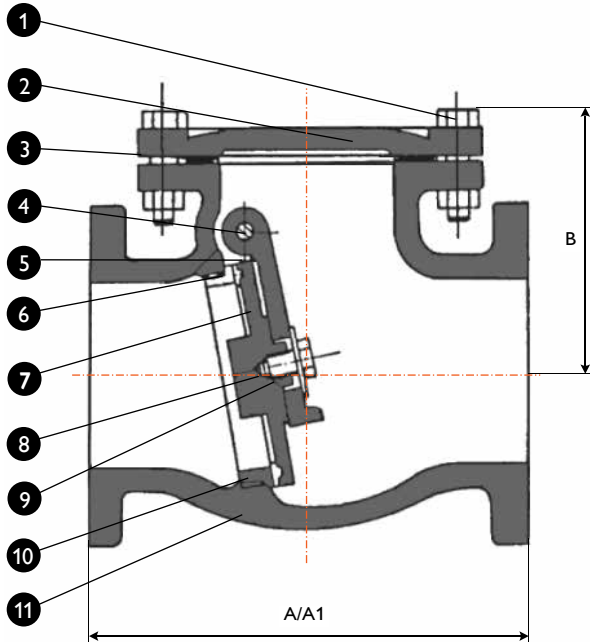

**MATERIAL LIST**

No.	Part Name	Material
1	Cover Bolt & Nut	Steel ZP
2	Cover*	ASTMA126 Class B / A395
3	Gasket	Graphite / Teflon
4	Hanger Pin	304 or F6 Stainless Steel
5	Hanger	ASTMA126 Class B or A536 D.I.
6	Disc Ring	Bronze ASTM B62/F6/EPDM**/NBR**
7	Disc	ASTMA126 Class B
8	Disc Washer	Steel ZP
9	Disc Bolt	Steel ZP
10	Seat Ring	Bronze ASTM B62 or F6 SS
11	Body*	ASTMA126 Class B / A395

\* Ductile Iron Body for 250 Class and PN16 in larger sizes.

\*\* Soft Seat also available DIN 3202/3352 F6 Face to Face Dimension

**DIMENSIONS & WEIGHTS**

**MM & KG**

Class	Size (mm)	50	65	80	100	125	150	200	250	300	350	400	450	500	600
	Size (in)	2"	2.5"	3"	4"	5"	6"	8"	10"	12"	14"	16"	18"	20"	24"
125lb 150lb TABLE D TABLE E PN10 PN14 PN16	A	203	216	241	292	330	356	495	622	699	787	864	978	978	1295
	Weight* (A)	11	15	20	33	47	58	104	200	300	360	432	698	1080	1700
	A1	287	295	318	356	400	494	533	640	711	-	914	914	1016	1219
	Weight* (A1)	21	29	41	60	56	80	185	260	320	-	460	591	1100	1620
250lb TABLE F TABLE H PN21 PN35	B	131	146	157	182	230	237	278	313	353	434	470	535	570	679
	A	267	292	318	356	400	445	533	622	711	-	-	-	-	-
	B	133	152	159	184	206	229	279	337	383	-	-	-	-	-
	Weight*	21	29	41	60	80	114	186	220	340	-	-	-	-	-

Refer to drawing for other dimensions. \* Will vary depending on flanging.

The catalogue is general in its nature and design and can vary at any time. This catalogue is to be used as a guide only.

# SWING CHECK VALVE WITH LEVER & COUNTER-WEIGHT • SL404-CW

- Table D - SL404-D-CW**
- Table E - SL404-E-CW**
- PN10 - SL404-10-CW**
- PN14 - SL404-14-CW**
- PN16 - SL404-16-CW**
- PN21 - SL404-21-CW**
- PN25 - SL404-25-CW**
- 125 Class SL404-125-CW**
- 150 Class SL404-150-CW**
- 250 Class SL404-250-CW**

**Design**

BSEN 16767 (BS 5153), MSS-SP71 Type 1, ANSI B16.1

**Flanging/Pressure Class**

ANSI B16.1125lb, 150lb, 250lb

ANSI B16.42 150lb, 250lb

AS 2129 table D, E, F, H

AS 4087 PN10, PN14, PN16, PN21, PN35

ISO 7005-1, PN10, PN16, PN25

AS 4331.1 PN10, PN16, PN25

EN 1092-2 PN10, PN16, PN25

JIS B2220 5K, 10K, 16K, 20K

**Face to Face Dimensions**

ASME B16.10, EN 558-1, EN 558-2, EN 16767 (BS 5153)

(AS 4794 on request)

**Test Standard**

AS 4794, EN 12266-1, MSS-SP71, ISO 5208, API 598

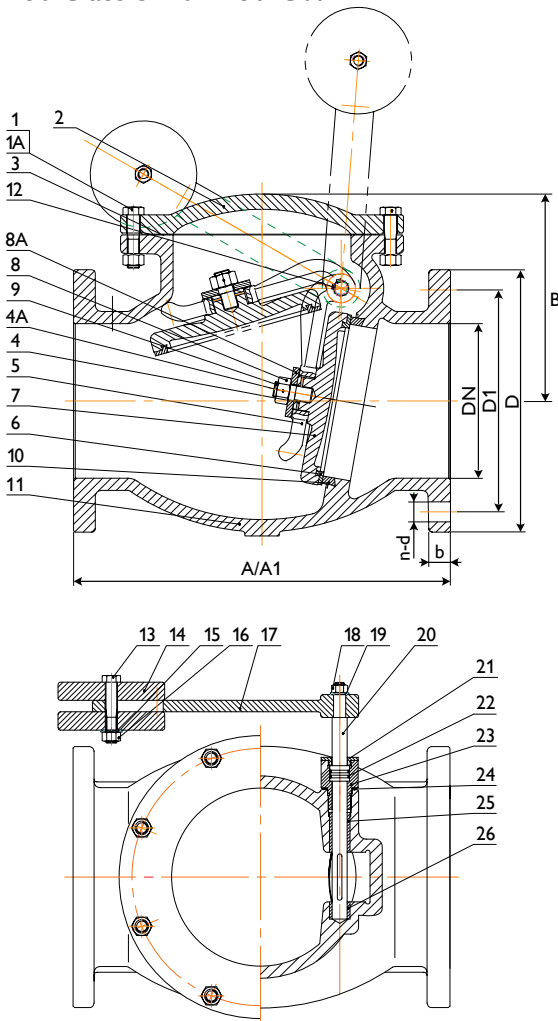

**MATERIAL LIST**

No.	Part Name	Material
1/1A	Cover Bolt & Nut	Steel
2	Cover*	ASTM A126 Class B
3	Gasket	Graphite / Teflon
4/4A	Hanger Pin & Split	304 or F6 Stainless Steel
5	Hanger	ASTM A536 Ductile Iron
6	Disc Ring	Bronze ASTM B62/F6/EPDM/NBR
7	Disc	ASTM A126 Class B
8/8A	Disc Washer & Nut	Steel
9	Disc Bolt	Steel
10	Seat Ring	Bronze ASTM B62 or F6 SS
11	Body*	ASTM A126 Class B
12	Retainer	Stainless Steel
13	Bolt	Steel
14	Balance Weight	Cast Iron
15	Washer	Steel
16	Nut	Steel
17	Connecting Lever	Ductile Cast Iron
18	Nut	Steel
19	Washer	Steel
20	Hanger Axle	Stainless Steel
21	Gland	Brass
22	O-Ring	EPDM/NBR
23	Stuffing Box	Brass
24	Washer	Teflon
25	Outside Bush	Brass
26	Inside Bush	Brass

\* Ductile Iron Body for 250 Class and PN16 in larger sizes.

**DIMENSIONS**

**MM**

Class	Size (mm)	50	65	80	100	125	150	200	250	300	350	400	450	500	600
	Size (in)	2"	2.5"	3"	4"	5"	6"	8"	10"	12"	14"	16"	18"	20"	24"
125lb, 150lb Table D, Table E PN10, PN14, PN16	A	203	216	241	292	330	356	495	622	699	787	864	978	978	1295
	A1	287	295	318	356	400	494	533	640	711		914	914	1016	1219
	B	131	146	157	182	230	237	278	313	353	434	470	535	570	679
	D	152	178	190	228.6	254	279.4	343	406	483	535	597	635	700	815
PN21,PN25, PN35, 250lb Table F, Table H	D1	121	140	152.5	190.5	215.9	241.3	298.5	362	432	476	540	578	635	749
	A	267	292	318	356	400	445	533	622	711	-	-	-	-	-
	B	22.2	25.4	28.6	31.8	34.9	36.5	41.3	47.6	50.8	-	-	-	-	-
	D	165	191	210	254	279	318	381	445	521	-	-	-	-	-
	D1	127	149	168	200	235	270	330	387	451	-	-	-	-	-

Refer to drawing for other dimensions.

The catalogue is general in its nature and design and can vary at any time. This catalogue is to be used as a guide only.

## CHECK VALVE (NON-RETURN) TYPE APNX

### UNIFLO®

Cast Iron or rubber lined cast iron body, semi flexible disc, swing check.  
Flow reversal of plus 0.35 bar. Design BS 5158, BSEN 12334.

#### RANGE OF APPLICATION

Size MM	Pressure Rating Bar	Hyd. test pressure in bar for	
		Body	Seat
25 - 350	7.0	10.5	7.7

#### Flanging

Connecting dimensions & thickness to ANSI(ASA)/BS/AS/EN/ISO specifications to suit ANSI B16.1 125LB, EN 1092-2, PN 6~16, AS 4087 PN 10~16, AS 2129 Table D to E, ISO 7005-1 PN 6~16, AS 4331.1 PN 6~16. EN 1092-2 PN 6~16.

#### MATERIAL LIST

Part Name	Material
Body/End Piece	Cast Iron IS: 210 Gr. FG. 260 with hard/soft rubber lining
Disc (or flap)	Steel reinforced plate rubber lined. Available in neoprene, viton, teflon etc. Grade "B" Butyl is standard.
Connecting bolts/nuts	Steel IS: 1367, Gr. 4.6/4
Valve Surface protection	Prime coat: chlorine-free with modified alkyd resin.
Linings Available	Food grade, halar, hard rubber, teflon etc.

#### FEATURES

Simple three parts design, with only one moving part. Disc, absolutely 100% leak tight, 0.035 bar back pressure. Full bore design for minimum flow turbulence. Flap also serves as gasket seal between body and end piece. Valve usable in vertical or horizontal plane. Down time is kept to a minimum as the flap can easily be replaced in minutes.

#### DIMENSIONS

Size (mm)	Size (in)	Face to Face Dimensions A		Overall Dimensions B mm	Weight approx. kg.
		Unlined mm	Rubber Lined mm		
25	1"	151	157	124	4.0
40	1-1/2"	180	186	149	7.0
50	2"	198	204	162	8.5
65	2-1/2"	238	244	216	14.0
80	3"	259	265	216	20.0
100	4"	348	356	295	34.0
150	6"	400	406	327	56.0
200	8"	492	500	396	103.0
250	10"	590	600	500	190.0
300	12"	690	700	554	310.0

Rubber lining specification according to flow medium & working temperature.

Cast on flow direction arrow ensures correct installation.

When placing order, please specify flow medium, working pressure and working temperature.

Not recommended for use under vacuum pressure.

The catalogue is general in its nature and design and can vary at any time. This catalogue is to be used as a guide only.

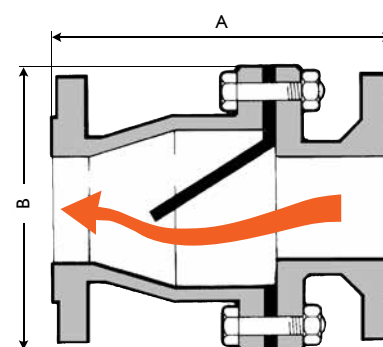

# GATE VALVE BBISY CAST IRON BODY PN10~35, ANSI CLASS 125~250 • SL600

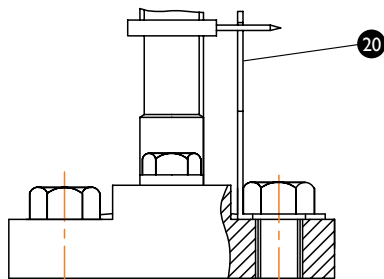
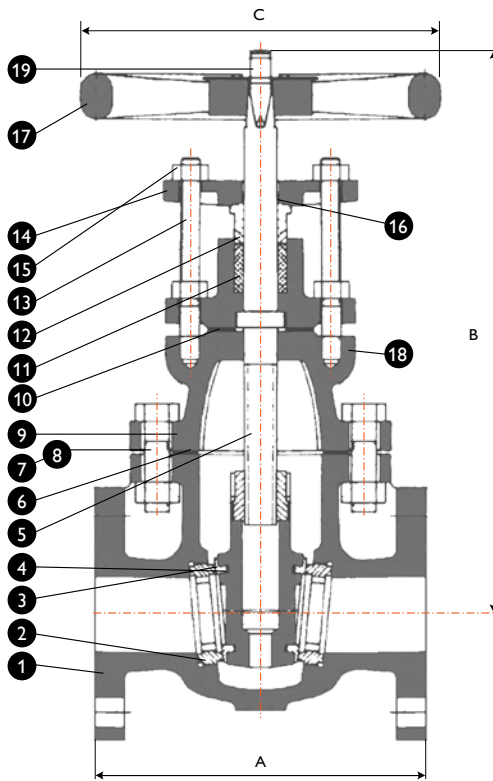

Optional Position Indicator

- PN10 SL600-10**
- PN14 SL600-14**
- PN16 SL600-16**
- PN21 SL600-21**
- PN35 SL600-35**
- Table D SL600-D**
- Table E SL600-E**
- Table F SL600-F**
- 125 Class SL600-125**
- 150 Class SL600-150**
- 250 Class SL600-250**

**Design**  
MSS SP70-1, MSS SP-128,  
BSEN 1171 (BS 5150), AS 2638.1

**Features**  
Inside screw & yoke, solid wedge, bolted bonnet, non-rising stem.

**Flanging/Pressure Class**  
ANSI B16.1 125lb, 150lb, 250lb  
ANSI B16.42, 150lb, 250lb  
AS 2129 Table D, E, F, H  
AS 4087 PN14, PN16, PN21, PN35  
AS 4331.1 PN10, PN16  
EN 1092-2 PN10, PN16  
ISO 7005-1, PN10, PN16  
JIS B2220 5K, 10K, 16K, 20K

**Face to Face Dimensions**  
EN 1171 (BS 5150), ASME B16.10,  
AS 2638.1, EN 558-1, MSS SP70.

### MATERIAL LIST

No.	Part Name	Material
1	Body	ASTM A126 Class B/A395
2	Seat Ring	ASTM B62 (bronze*)
3	Wedge Face Ring	ASTM B62 (bronze*)
4	Wedge	ASTM A126 Class B
5	Stem*	Bronze/Brass/F6/420
6	Body Gasket	Graphite/NBR
7	Bolt	Steel B7
8	Nut	Steel 2H
9	Bonnet	ASTM A126 Class B/A395
10	Gasket	PTFE/Graphite
11	Packing	Graphite/PTFE
12	Packing Gland	Cast Brass/410SS
13	Packing Gland Bolt	Alloy Steel B7
14	Gland Flange Nut	Alloy Steel 2H
15	Gland Flange	Cast Brass/410SS
16	Yoke Bushing Nut	ASTM A126 Class B
17	Handwheel**	ASTM A126 Class B
18	Identification Plate	Aluminium
19	Handwheel Nut	Ductile Iron
20	Position Indicator Plate†	Aluminium (Optional)

NOTE: \*Bronze B16 or stainless steel CR13/304/316 refer to drawing.  
\*\*For gear operator refer to drawing. †Optional, refer to drawing.

MM & KG

### DIMENSIONS & WEIGHTS

Class	Size	Dimensions (mm)																		
		(in)	50	65	80	100	125	150	200	250	300	350	375	400	450	500	600	700	750	900
		2"	2.5"	3"	4"	5"	6"	8"	10"	12"	14"	15"	16"	18"	20"	24"	28"	30"	36"	
125lb, 150lb Table D Table E PN10, PN14 PN16	A	178	191	203	229	254	267	292	330	356	381/441	406/476	406/476	432/505	457/510	508/575	610	610	711	
	B	313	334	370	430	454	550	678	750	880	940	950	1080	1180	1380	1480	-	-	-	
	C	203	203	203	254	254	305	356	406	457	508	560	559	610	610	762	-	-	-	
	Weight	15	21	26	44	61	74	127	216	283	375	550	638	800	980	1300	-	2836	3500	
250lb Table F Table H PN21, PN35	A	216	241	282	305	381	403	419	457	502	-	-	-	-	-	-	-	-	-	
	B	315	340	390	440	460	560	678	798	895	-	-	-	-	-	-	-	-	-	
	C	203	229	254	305	305	406	508	559	610	-	-	-	-	-	-	-	-	-	
	Weight	23	41	54	84		166	272	418	636	-	-	-	-	-	-	-	-	-	

NOTE: Indicative drawing only. Detailed drawing & bill of material can be furnished on request

The catalogue is general in its nature and design and can vary at any time. This catalogue is to be used as a guide only.

# GATE VALVE BBOSSY CAST IRON BODY PN10~21 ANSI CLASS 125~250 • SL601

- PN10 SL601-10**
- PN14 SL601-14**
- PN16 SL601-16**
- PN21 SL601-21**
- Table D SL601-D**
- Table E SL601-E**
- Table F SL601-F**
- 125 Class SL601-125**
- 150 Class SL601-150**
- 250 Class SL601-250**

**Design**

MSS SP70-1, MSS SP-128, BSEN 1171 (BS 5163), AS 3579, AS 2638.1 AWWA C500-09.

**Features**

Outside screw & yoke, solid wedge, bolted bonnet, rising stem.

**Flanging/Pressure Class**

ANSI B16.1 125lb, 150lb, 250lb  
ANSI B16.42, 150lb, 250lb  
AS 2129 Table D, E, F, H  
AS 4087 PN10, PN14, PN16, PN21, PN35  
AS 4331.1 PN10, PN16  
EN 1092-2 PN10, PN16  
ISO 7005-1, PN10, PN16  
JIS B2220 5K, 10K, 16K, 20K

**Face to Face Dimensions**

EN 1171 (BS 5163), ASME B16.10, AS 2638.1, EN 558-1, MSS SP70.

**MATERIAL LIST**

No.	Part Name	Material
1	Body	ASTM A126 Class B/A395
2	Seat Ring	ASTM B62 or F6*2
3	Wedge Face Ring	ASTM B62 or F6*2
4	Wedge	ASTM A126 Class B/A395
5	Stem	Bronze/410SS
6	Body Gasket	Graphite/Full Face Nitrile
7	Bolt	Steel
8	Nut	Steel
9	Bonnet	ASTM A126 Class B/A395
10	Back Seat Bushing *4	Cast Brass/410SS *4
11	Packing	Graphite/PTFE
12	Packing Gland	Cast Brass/410SS
13	Packing Gland Bolt	Steel
14	Gland Flange Nut	Steel
15	Yoke Bushing	Ductile Iron
16	Gland Flange	Cast Brass/410SS
17	Yoke Bushing Nut	ASTM A126 Class B
18	Screw	Steel
19	Handwheel*3	ASTM A126 Class B
20	Identification Plate	Aluminium
21	Handwheel Nut	Ductile Iron or B62

\*2 Available in 304, 316, 410, Bronze or Brass trim. \*3 For Gear Operated version refer to drawing. \*4 250 Class only. (Optional on 125lb & PN16).

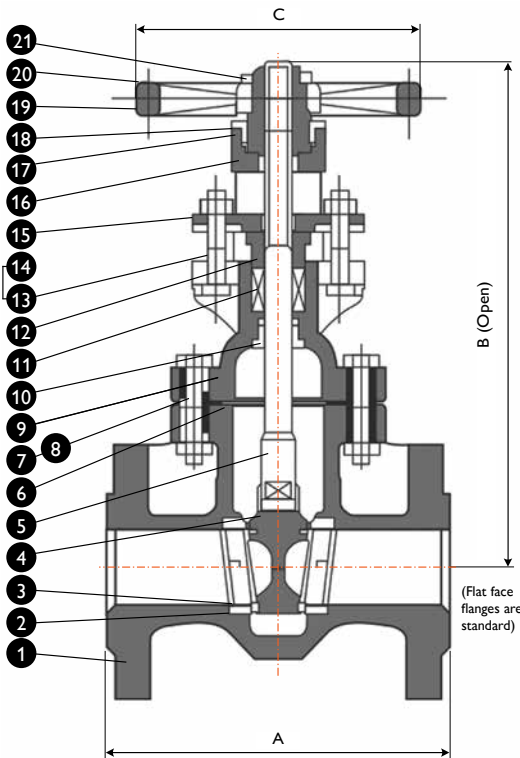

**DIMENSION & WEIGHTS**

**MM & KG**

Class	Size (mm)	50	65	80	100	125	150	200	250	300	350	400	450	500	600	750	900
	Size (in)	2"	2.5"	3"	4"	5"	6"	8"	10"	12"	14"	16"	18"	20"	24"	30"	36"
125lb, 150lb Table D, Table E PN10, PN14, PN16	A	178	191	203	229	254	267	292	330	356	381	406	432	457	508	610	711
	B*	375	408	441	545	656	770	959	1260	1486	1689	1860	2106	2300	2530	3400	3950
	C	203	203	203	254	254	305	356	406	457	508	559	610	610	762	-	-
	Weight	15	21	26	44	61	74	127	216	315	409	640	726	782	1353	2936	3600
250lb Table F, Table H PN21, PN35	A	216	241	282	205	216	403	419	457	502	-	-	-	-	-	-	-
	B*	368	445	521	629	800	876	1092	1340	1524	-	-	-	-	-	-	-
	C	203	229	254	305	305	406	508	559	610	-	-	-	-	-	-	-
	Weight	23	41	54	84	120	166	272	418	636	-	-	-	-	-	-	-

NOTE: Indicative drawing only. Detailed drawing & bill of material can be furnished on request. Special face to face dimensions also available.  
\*Open.

The catalogue is general in its nature and design and can vary at any time. This catalogue is to be used as a guide only.



# GLOBE VALVE BBOSSY CAST IRON BODY PN10~35 ANSI CLASS 125~250 • SL201

**PN10 SL201-10**  
**PN14 SL201-14**  
**PN16 SL201-16**  
**PN21 SL201-21**  
**PN35 SL201-35**  
**125 Class SL201-125**  
**150 Class SL201-150**  
**250 Class SL201-250**

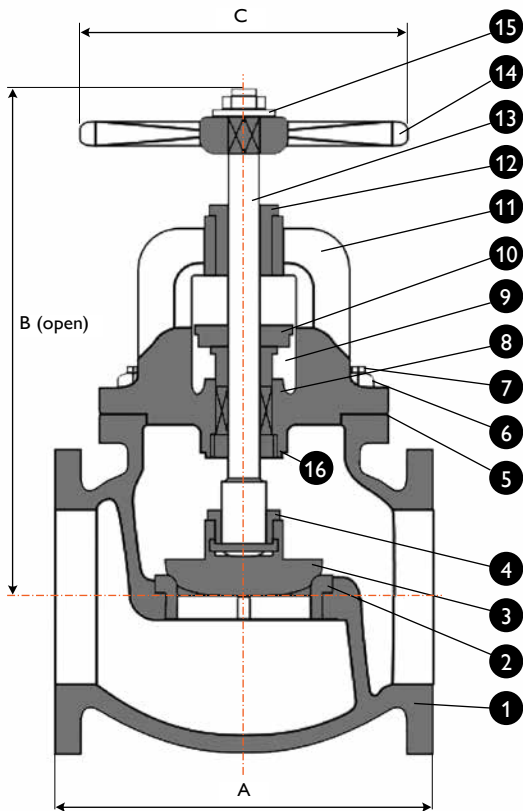
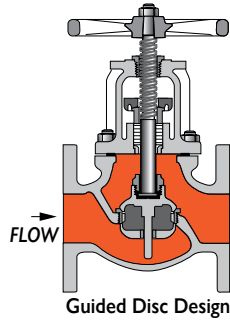

**Design**  
 ANSI B16.1, ANSI B16.42, MSS SP85, BSEN 13789 (BS 5152).  
**Features**  
 Outside screw & yoke, bolted bonnet, rising stem/handwheel.  
**Flanging/Pressure Class**  
 ANSI B16.1 125lb, 150lb, 250lb  
 AS 2129 ANSI B16.42 150lb, 250lb  
 AS 2129 Table D, E, F, H  
 AS 4087 PN10, PN14, PN16, PN21, PN35  
 AS 4331.1 PN10, PN16  
 EN 1092-2 PN10, PN16  
 ISO 7005-1, PN10, PN16  
**Face to Face Dimensions**  
 EN 558-1 Series 10, ASME B16.10, MSS SP85.

### MATERIAL LIST

No.	Part Name	Material
1	Body	ASTMA126 Class B/A395
2	Seat Ring	ASTM B62 or F6
3	Disc	ASTMA126 Class B
4	Disc Stem Ring	ASTM B62 or F6
5	Body Gasket	Graphite/Full Face Nitrile
6	Nut	Steel
7	Bolt	Steel
8	Packing	Graphite/PTFE
9	Packing Gland	Cast Brass or F6
10	Gland Flange	Ductile Iron/A395
11	Bonnet	ASTMA126 Class B/A395
12	Yoke Bushing	Cast Brass or F6
13	Stem	ASTM B16 or F6A
14	Handwheel*	ASTM B126 Class B
15	Handwheel Nut	Ductile Iron
16	Back Seat (optional)	ASTM B62 or 410

\* For gear operator refer to drawing.  
 Bronze or stainless steel stem and/or trim also available.  
 Maximum temperature 210°C

### DIMENSION & WEIGHTS

MM & KG

Class	Size (mm)	50	65	80	100	125	150	200	250	300	350	400	450	500	600
	Size (in)	2"	2.5"	3"	4"	5"	6"	8"	10"	12"	14"	16"	18"	20"	24"
125lb, 150lb Table D, Table E PN10, PN14, PN16	A	203	216	241	292	330	356	495	622	699	787	864	978	978	1295
	B	335	356	392	446	489	516	663	832	1270	1430	1430			
	C	203	203	229	254	305	305	406	508	600	600	600			
	Weight	23	27	34	54	71	95	180	325	340	396	560	725	881	1276
250lb Table F, Table H PN21, PN35	A	267	292	318	356	400	445	533	622	711					
	B	349	375	419	470	530	591	724	832	1290					
	C	229	254	254	305	350	406	508	535						
	Weight	28	37	54	73	100	145	259							

Dimensions and weights are an example only, refer to as-built drawing as dimensions vary according to standard.

The catalogue is general in its nature and design and can vary at any time. This catalogue is to be used as a guide only.

# RIGHT ANGLE GLOBE VALVE CAST IRON BODY ANSI CLASS 125/PN14/16/TABLE E • SLHU/J4432

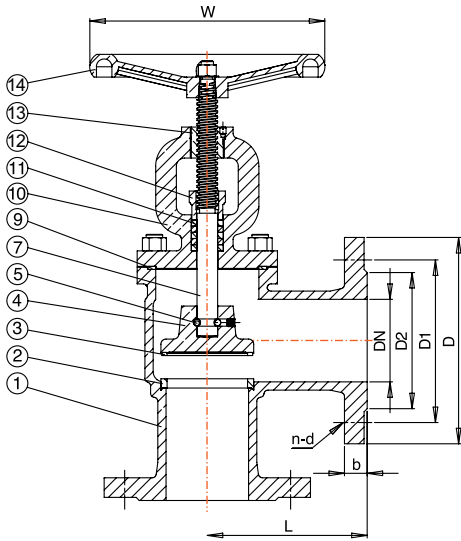

### MATERIALS LIST

Item	Part Name	Material	Item	Part Name	Material
1	Body	Iron - GG25	9	Bonnet Gasket	Graphite With Soft Steel
2	Seat Ring	Stainless Steel	10	Bonnet	Iron - GG25
		Brass	11	Packing	Graphite
3	Disc Ring	Stainless Steel	12	Packing Gland	Brass
		Brass			Stainless Steel
4	Disc	GG25/Carbon Steel	13	Stem Nut	Brass
5	Relief Spring	AISI 410	14	Handwheel	Iron A211-B
7	Stem	SS AISI 420			

### Features

Bolted bonnet outside screw & yoke (clockwise closing direction.) Available as Standard Globe and Screw-Down Non-Return (combination globe and check valve), Swivel Disc - guided loose disc for combination check and stop.

### Design

ANSI B16.1, MSS SP85, BSEN 13789 (BS 5152), ANSI B16.42.

### Flanging/Pressure Class

ANSI B16.1 125lb, 150lb  
ANSI B16.42 150lb  
AS 2129 Table D, E, F, H  
AS 4087 PN14, PN16, PN21  
AS 4331.1 PN10, PN16  
EN 1092-2 PN10, PN16  
ISO 7005-1 PN10, PN16  
JIS B2220 5K, 10K, 16K, 20K

### Face to Face Dimensions

BSEN 13789 (BS 5152), BS.558, ASME B16.10, MSS SP85.

### DIMENSIONS & WEIGHTS

### MM & KG

Size (mm)	Size (inch)	L	D	D1	D2	b	n-d	H(open)	W	W.T(kg)
15	1/2"	90	95	65	45	14	4-14	200	120	3.5
20	3/4"	95	105	75	58	16	4-14	220	120	4.2
25	1"	100	115	85	68	16	4-14	225	120	5.1
32	1-1/4"	105	140	100	78	18	4-18	250	120	7.3
40	1-1/2"	115	150	110	88	18	4-18	270	160	9.0
50	2"	125	165	125	102	20	4-18	290	200	14.6
65	2-1/2"	145	185	145	122	20	4-18	320	200	19.8
80	3"	155	200	160	138	22	8-18	365	200	23.6
100	4"	175	220	180	158	24	8-18	410	240	31.4
125	5"	200	250	210	188	26	8-18	460	240	46.0
150	6"	225	285	240	212	26	8-22	525	280	58.4
200	8"	275	340	295	268	30	12-22	685	360	113.8
250	10"	325	405	355	320	32	12-26	830	400	143.6
300	12"	375	460	410	378	32	12-26	925	450	176.5

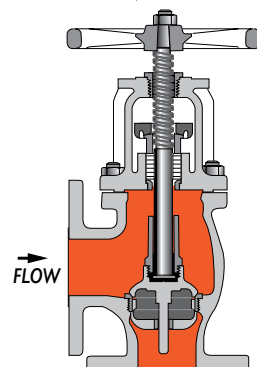

Guided Disc Design

The catalogue is general in its nature and design and can vary at any time. This catalogue is to be used as a guide only.

## DIAPHRAGM VALVE WEIR • APA

APA Weir Type Valve offers smooth flow & simple operation in any position. Parts interchange with the existing market leader of diaphragm valves and dimensions are the same. Its design provides extra-long diaphragm life for throttling and positive shut-off services. Hygienic style also available.

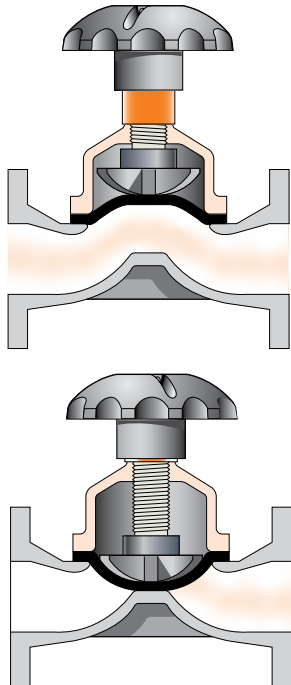
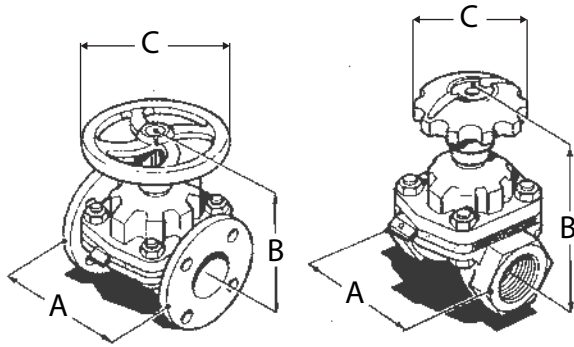

**Size Range**  
8mm to 350mm.

**Design**  
EN 13397 (BS 5156)

**Temperature Range**  
-45°C to 171°C.

**Body Linings**  
Hard Rubber, Soft Rubber, Neoprene, Glass, Butyl, Ceramic, PFA, PP, ETFE, Polypropylene, Halar & PVDF

**Diaphragms**  
Butyl, EPDM, Polyethylene, Polychloroprene.

**Design Advantages**

The body of which gives a smooth pocketless flow and features low pressure drop. Suitable for high line pressure duties and is available in a range of trims & materials for gases and liquids.



FLOW PATH

**Bonnet Assembly**  
Contains a compressor which supports the diaphragm at all stages of travel

**Diaphragm**  
Specially shaped to achieve leak tight seat against wall.

**Pressure Range**  
to 1580 kPa.

**Body Materials**  
Cast Iron, Ductile Iron, Bronze, Aluminium and Stainless Steel

**Flangings**  
AS 2129 Table D/E/F  
ANSI 125  
AS 4087 PN14/PN16  
AS 4331.1 PN10/PN16.



DIMENSIONS, WEIGHTS & PRESSURES (APA)

MM, KG & BAR

Valve Size		Female Screwed Ends			EN 13397 (BS 5156) Flanged Ends					Maximum Working Pressures		Weights	
(DN)		A (mm)	B (open)	C	A (mm)			B (open)	C	Bar		Kg.	
mm	inches	unlined			unlined	lined	Polymers or Glass lined			Diaphragm		Screwed	Flanged
										Rubber	PTFE		
08	1/4"	48	59		-	-	-	-		16	10	0.15	-
10	3/8"	48	68		-	-	-	-		16	10	0.26	-
15	1/2"	64	91	70	108	114	110	100	70	16	10	0.52	1.5
20	3/4"	83	94	70	117	123	119	100	70	16	10	0.85	2.2
25	1"	108	115	100	127	133	129	110	100	16	10	1.40	2.9
32	1-1/4"	121	152	100	146	152	148	150	100	16	10	2.20	3.8
40	1-1/2"	140	164	140	159	165	161	160	140	16	10	2.70	4.7
50	2"	165	187	140	190	196	192	180	140	16	10	4.15	7.7
65	2-1/2"	203	224	140	216	222	218	214	140	10	10	10.30	13.2
80	3"	254	233	225	254	260	256	220	225	10	10	15.65	19.0
100	4"	-	-	225	305	311	307	300	225	10	10	-	32.0
125	5"	-	-	310	356	362	358	375	310	10	10	-	45.0
150	6"	-	-	368	406	412	408	430	368	10	7	-	67.0
200	8"	-	-	471	521	527	523	507	471	7	6	-	141.0
250	10"	-	-	587	635	641	637	588	587	5	5	-	240.0
300	12"	-	-	690	749	755	751	683	690	4	-	-	329.0
350	14"	-	-	690	749	755	751	693	690	3.5	-	-	429.1

The catalogue is general in its nature and design and can vary at any time. This catalogue is to be used as a guide only.

## DIAPHRAGM VALVE STRAIGHT THROUGH • APKB

APKB Straight Thru Valves efficiently handle abrasive and corrosive slurries, thick coagulating fluids, and a wide variety of suspended solid materials. Parts interchange with the existing market leader of diaphragm valves and dimensions are the same.

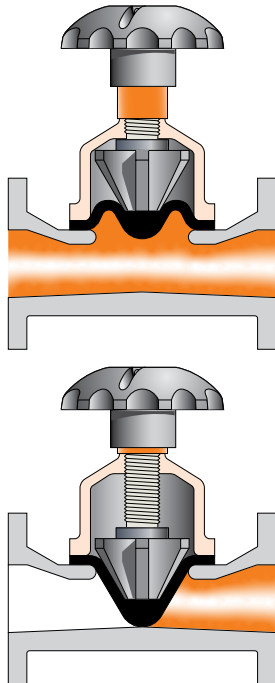
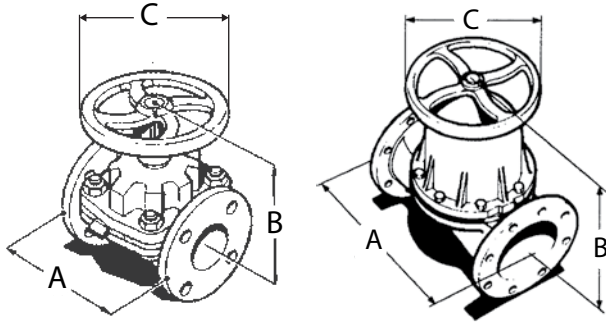

**Size Range**  
15mm to 350mm.

**Pressure Range**  
Vacuum to 690 kPa.

**Design**  
EN 13397 (BS 5156)

**Body Materials**  
Cast Iron, Ductile Iron, Bronze, Aluminium and Stainless Steel

**Temperature Range**  
-40°C to 121°C.

**Flangings**  
AS 2129 Table D/E/F  
ANSI 125  
AS 4087 PN14/PN16  
AS 4331.1 PN10/PN16.

**Body Linings**  
Cast Iron, Hard Rubber, Soft Rubber, Neoprene, Glass Lined, Butyl, Ceramic, PFA, PP, ETFE, PVDF.

**Diaphragms**  
Butyl, EPDM, Polyethylene, Polychloroprene.

**Design Advantages**  
The body design offers minimum friction, no turbulence & is suitable for sludge and slurry pressure gases.



**FLOW PATH**

**Bonnet Assembly**  
The compressor & spindle design gives a long travel sufficient to contact the valve body seat & to lift the diaphragm up into the bonnet to provide total clearance of the pipeline.



**Diaphragm**  
Specially shaped to achieve leaktight seat against valve wall.

**Body**  
Allows greater flow and is suitable for rodding through.

### DIMENSIONS, WEIGHTS & PRESSURES (APKB)

MM, KG & BAR

Valve Size		Flanged Ends						Screwed Ends				Maximum Pressure
(DN)		A (mm)			B (open)	C	Weight	A (mm)	B (open)	Weight	C	
mm	inches	unlined	Polymers or Glass lined	Rubber lined			Kg.	unlined		Kg.		Bar
15	1/2"	108	110	-	106	70	2.0	64	106	0.7	70	10
20	3/4"	117	119	123	115	70	2.5	95	120	0.8	70	10
25	1"	127	129	133	160	100	3.0	111	164	2.0	100	10
32	1-1/4"	146	148	152	160	100	4.3	124	164	2.2	100	10
40	1-1/2"	159	161	165	182	140	5.4	143	164	2.7	140	10
50	2"	190	192	196	230	140	8.0	168	189	4.9	140	10
65	2-1/2"	216	218	222	296	140	12.1	206	228	8.6	140	10
80	3"	254	256	260	303	225	21.5	257	302	15.6	225	10
100	4"	305	307	311	324	225	32.0	-	-	-	225	10
125	5"	356	358	362	346	310	48.2	-	-	-	310	6
150	6"	406	408	412	470	368	65.0	-	-	-	368	6
200	8"	521	523	527	640	471	104.0	-	-	-	471	3.5
250	10"	635	637	641	745	587	208.0	-	-	-	587	3.5
300	12"	749	751	755	785	690	306.4	-	-	-	690	3.5

Rising handwheel and stem sizes DN 015-150. Non-rising handwheel in sizes DN 200-300

The catalogue is general in it's nature and design and can vary at any time. This catalogue is to be used as a guide only.

# KNIFE GATE VALVE - MODEL DCNP OVERVIEW - UNI-DIRECTIONAL

## DESIGN

### Flanging

ANSI B16.1/B16.5 125lb/150lb  
AS 2129 Table D, E  
AS 4087 PN14, PN16  
ISO 7005-1, PN10, PN16  
AS 4331.1 PN10, PN16  
EN 1092-2 PN10, PN16

### Pressure/Class

#### Rating

PN10 Rated Body.  
Long Term Maximum  
Packing & Seat Rating:  
10 bar to 250NB  
7 bar 300 ~ 450NB  
4 bar 500 ~ 600NB

### Face to Face Dimensions

AS 640I & MSS SP-81

### Test Standards

MSS-SP71, ISO 5208, MSS SP-SP61

### Pressure/Temperature

#### Rating Seat

NBR 10 bar -10 to 90°C  
EPDM 10 bar -10 to 120°C  
Viton 10 bar -10 to 200°C  
PTFE 10 bar -10 to 200°C  
Metal to Metal 10 bar -10 to 200°C

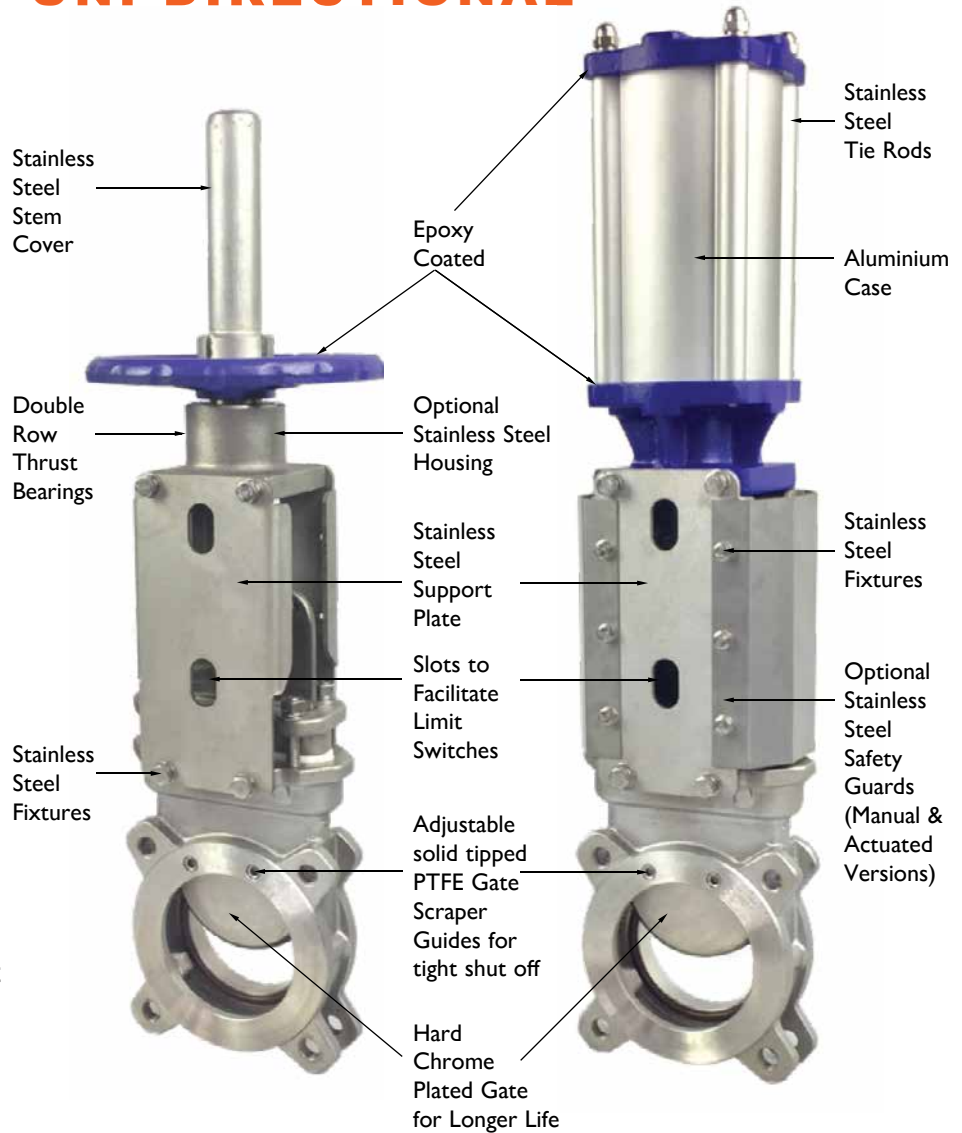

Resilient seated uni-directional valves are tested leak tight up to 4 Bar (Elastomer) and 2.8 Bar (PTFE) on seat. The Flowturn DCNP is one of the only Knife Gate designs in the world offering a rugged and flexible PTFE seated valve with a tight shut-off. Above 4 Bar these pressures seat leakage rate is estimated at up to 2.66 drops/minute/inch (0.11 drips/minute/DN) as per MSS-SP61. However an actual seat test can be performed above 4.0 Bar if required. Special packing systems and bonnet designs are available for high pressure applications.

Flow direction is from the opposite side of the valve for the seat This provides superior shut-off by pressure energising the gate against the seat and also protects the seat.

# KNIFE GATE VALVE - MODEL DCNP

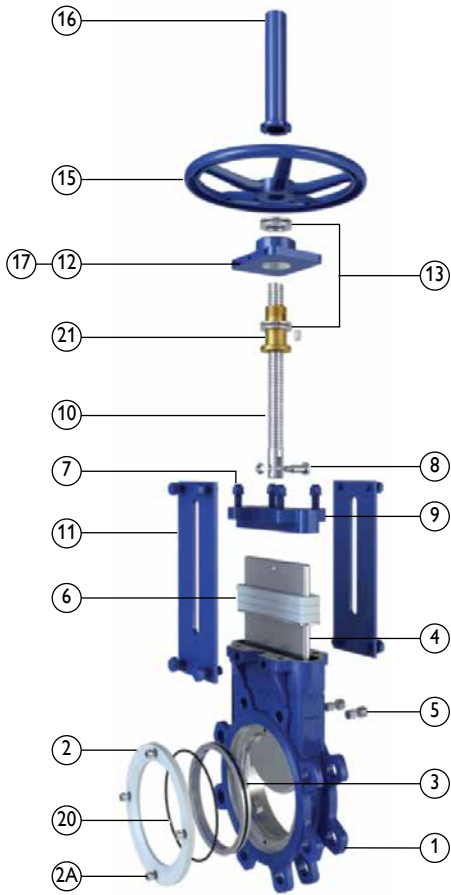

## MATERIALS

Item	Part Name	Material
1	Body	CF8M/CF8/WCB+FBE
2	Seat Retainer	SS316/SS304/WCB+FBE
2A	Seat Retainer Tension Screws	A2-70 SS/A4-70 SS
3	Seat	Metal STL#6/HCr/NBR/PTFE/EPDM/Viton
4	Gate	SS304/SS316+HCr
5	Adjustable Gate Guide	SS304/SS316+Solid PTFE
6	Packing Multi Layer	PTFE Braided+Silicon+ PTFE Sheet
7	Bolts	A2-70 SS/A4-70 SS
8	Pin	SS304
9	Gland	CF8M/CF8/WCB+FBE
10	Stem	SS304/2CR13
11	Support Plates	SS304
12	Bearing Housing	SS316/304/WCB+FBE
13	Bearings	SS440
15	Handwheel	Epoxy Coated Iron
16	Stem Cover	SS304
17	Grease Fitting	C95200+2P
20	O-Ring*	EPDM/NBR/Viton
21	Stem Drive Nut	Brass/SS304

\* PTFE and metal seat version.

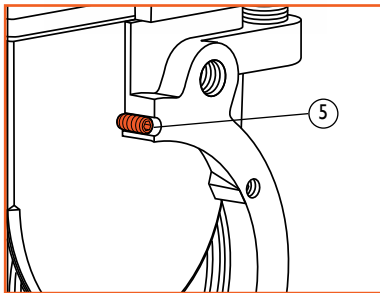

## PACKING AREA

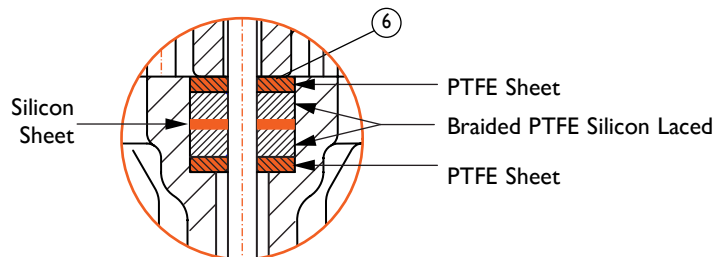

## SEAT AREA

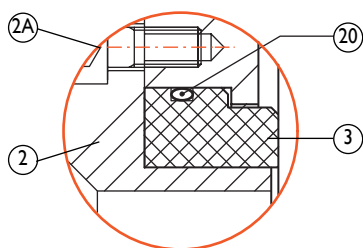

## GATE TENSION GUIDE

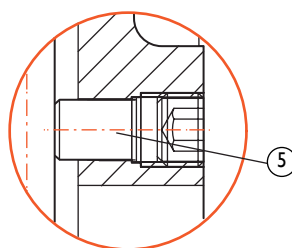

## GUIDE CLAWS

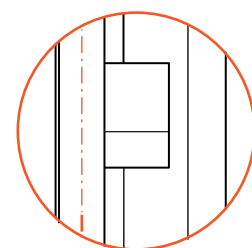

# KNIFE GATE VALVE - MODEL DCNP

## MATERIALS LIST - MANUAL OPERATED

Item	Part Name	Material
1	Body	CF8M/CF8/WCB+FBE
2	Seat Retainer	SS316/SS304/WCB+FBE
2A	Seat Retainer Tension Screw	A2-70 SS/A4-70 SS
3	Seat	Metal STL#6/HCr/NBR/PTFE/EPDM/Viton
4	Gate	SS316/SS304+HCr
5	Adjustable Gate Guide Scraper SS + Solid PTFE Tip	A2-70/A4-70+PTFE
6	Packing Multi Layer	Braided PTFE+Silicon+PTFE Sheet
7	Bolt	A2-70 SS/A4-70 SS
8	Pin	SS304
9	Gland	CF8M/CF8/WCB+FBE
10	Stem	SS304/2CR13
11	Support Plates	SS304
12	Bearing Housing	SS316/SS304/WCB+FBE
13	Bearings	SS440
14	Bearing Cover	SS304
15	Handwheel	Epoxy Coated Iron
16	Stem Cover	SS304
17	Grease Fitting	C95200
18	Safety Guards	SS304
19	Bevel Gear (Ratio 4.5:1)	Assembly
20*	O-Ring*	EPDM/NBR/Viton
21	Stem Drive Nut	Brass/SS304

\* Metal and PTFE seat version only.

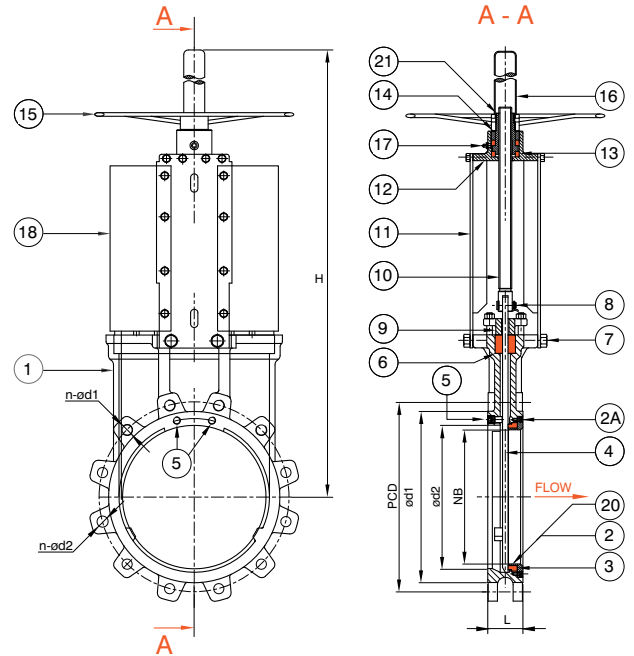

## DIMENSIONS & WEIGHTS AS2129 Table D\*/AS4087 CL14/16 (MM & KG)

NB	L	H	PCD	øD1	øD2	n-ød1	n-ød2	h1	h2	T	Weight
50	48	302	114	90	60	2-M16	2-M16	-	-	-	9.0
65	48	345	127	103	75	2-M16	2-M16	-	-	-	11.0
80	51	365	146	122	90	2-M16	2-M16	-	-	-	12.0
100	51	410	178	154	105	2-M16	2-M16	-	-	-	16.0
125	57	460	210	186	130	2-M16	6-M16	-	-	-	20.0
150	57	505	235	211	158	2-M16	6-M16	-	-	-	25.0
200	70	615	292	266	210	2-M16	6-M16	-	-	-	43.0
250	70	740	356	324	260	2-M20	6-M20	-	-	-	62.0
300	76	840	406	378	310	4-M20	8-M20	-	-	-	78.0
350	76	970	470	429	360	4-M24	8-M24	-	-	-	112.0
375	76	1020	495	463	385	4-M24	8-M24	-	-	-	145.0
400	89	1060	521	489	415	4-M24	8-M24	-	-	-	154.0
450	89	1810	584	532	465	4-M24	8-M24	1265	30	35	238.0
500	114	1950	641	609	515	6-M24	10-M24	1375	15	85	265.0
600	114	2205	756	720	615	6-M27	10-M27	1570	15	50	300.0
700	114	-	845	809	710	8-M27	12-M27	1710	15	50	510.0
750	114	-	927	888	725	8-M30	12-M30	1820	15	50	580.0
800	114	-	984	942	790	8-M33	12-M33	1950	15	50	640.0
900	114	-	1092	1050	860	10-M33	14-M33	2100	15	50	850.0
1000	114	-	1175	1133	980	10-M33	14-M33	2300	15	50	1100.0
1200	114	-	1410	1368	1180	14-M33	18-M33	2650	15	50	1680.0

\* Will also fit between Table E flanging all sizes (except 100NB, 250NB, 450NB)

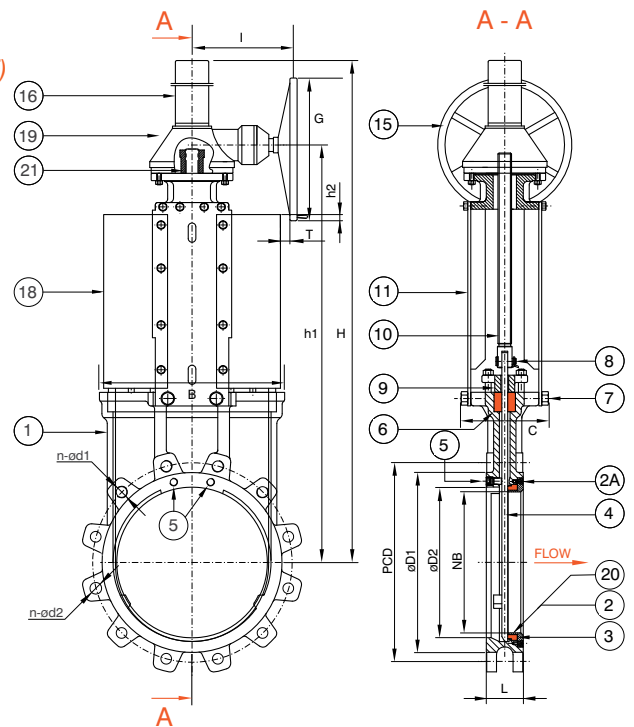

# KNIFE GATE VALVE - ACTUATOR DCNP/DCNP-B

## MATERIALS LIST - DOUBLE ACTING ACTUATOR

Item	Part Name	50mm~300mm	400mm & ABOVE
1	Piston Rod	1045+Hardchrome/304SS	1045+Hardchrome/304SS
2	Bottom Cover	Epoxy Coated Steel	Epoxy Coated Steel
3	Wear Ring	PTFE+Cu	PTFE+Cu
4	O-Ring	NBR/Viton	NBR/Viton
5	O-Ring	NBR/Viton	NBR/Viton
6	O-Ring	NBR/Viton	NBR/Viton
7	Piston	Aluminium Alloy	Cr Plated 1045
8	Cylinder Tube	Aluminium Alloy	Cr Plated 1045
9	Bolt	A2-70	A2-70
10	O-Ring	NBR	NBR
11	Stroke Adjuster	A2-70 SS	A2-70 SS
12	Cover Caps	Epoxy Coated Steel	Epoxy Coated Steel
13	Tie Rod	A2-70 SS	A2-70 SS
14	Seal Retainer	SS304	SS304
15	Scraper Seal	PTFE	PTFE
16	Bolt	A2-70 SS	A2-70 SS
17	O-Ring	NBR/Viton	NBR/Viton
18	V-Ring	Polyurethane	Polyurethane
19	Shaft Bearing	Brass	Brass
20	Shaft Seal	EPDM/NBR/Viton	EPDM/NBR/Viton

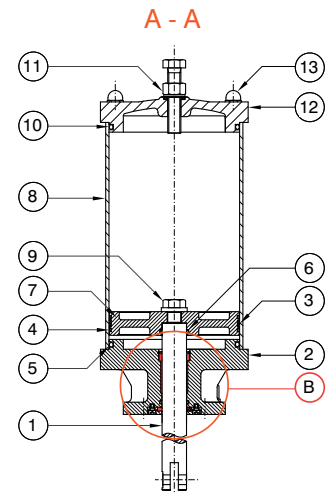

Exploded View B

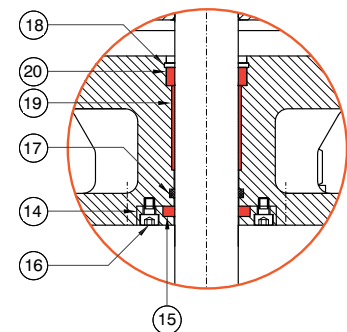

1/4" Air Connection

## DIMENSIONS & WEIGHTS - ACTUATED VALVE (MM & KG)

NB	H	W	Cylinder Bore	Stroke	Air Connect	Cylinder Weight	Valve & Actuator Weight
50	457	100	80	60	F1/4	6.3	15.0
65	505	100	80	75	F1/4	6.3	17.0
80	545	120	100	85	F1/4	6.3	18.0
100	615	120	100	105	F1/4	6.3	22.0
125	680	150	125	135	F1/4	9.2	29.0
150	780	150	125	160	F3/8	9.2	34.0
200	950	195	160	210	F3/8	26.0	69.0
250	1135	240	200	260	F3/8	39.0	101.0
300	1320	280	250	310	F3/8	60.0	138.0
350	1510	395	300	360	F3/8	103.0	215.0
375	1610	395	300	410	F3/8	103.0	230.0
400	1650	395	300	410	F3/8	103.0	250.0
450	2005	423	350	460	F3/8	136.0	320.0
500	2285	423	350	510	F3/8	138.0	360.0
600	2385	440	400	610	F3/8	146.0	392.0

Refer to APV sizing guide. Air supply 4 bar to 7 bar

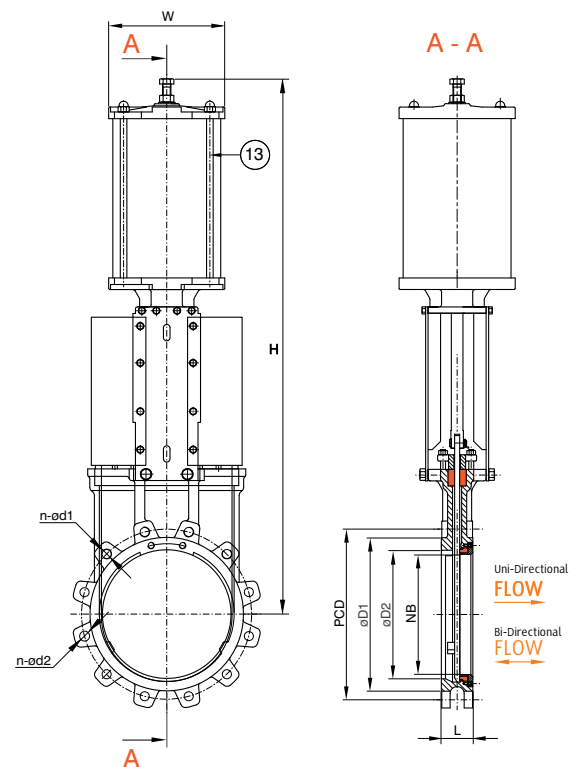



# Y-TYPE STRAINER SLCI-8111 SERIES

## CAST IRON 125LB ANSI B16.5/AS/BS TABLE D, E/PN10/PN14/PN16

Flanged to Suit 125LB ANSI B16.5, AS 2129 Table D, E / AS 4087 / ISO 7005-1 / AS 4331.1 PN10~21. Y-Type cast iron strainers are manufactured with Heavy Duty Spot welded stainless steel punched screens. Suitable for water, oil & numerous fluid applications. Flowturn strainers average 10 times the open area of the nominal pipe bore. Multiply this by the 'open area' of the screen size to calculate total open area. On average, this gives Flowturn strainers 3 to 4 times the pipe bore open area when using standard hole perforation sizes.

**Design** ASTM F1200-88, BSEN 1074, ANSI B16.1, EN 12266-1.

**Service Recommendations** These strainers are designed for long service. Installation of a strainer before any automatic equipment will ensure trouble free service and avoid the costly repairs or replacements so often caused by the introduction of foreign matter in pipe lines.

**Features** All sizes feature a bolted cover, as illustrated. Covers normally furnished with blowoff plug.

**Screens** Heavy gauge perforated stainless steel normally furnished with spot welded seams.

**Flanging** Available in: ANSI B16.5, AS 2129 Table D/E, AS 4087/AS 4331.1/EN 1092-2/ISO 7005-1 PN10~16 (PN25 and 250LB also available in ductile iron & carbon steel).



SLCI-8111

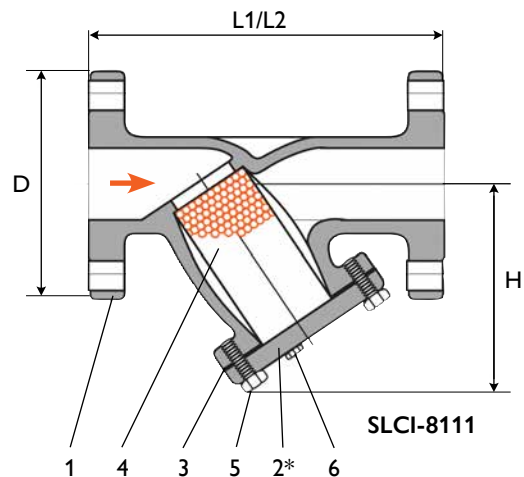
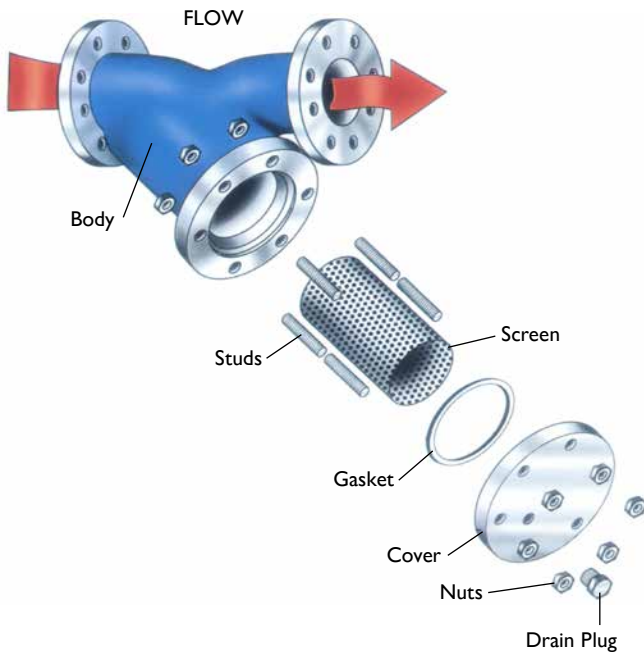

### FLOW RATE

Nom. Bore	Flow in L/sec at pressure drop of		
	3.5kPa	14kPa	34kPa
50	4.5	7.95	12.25
65	6.5	12.5	19.70
80	9.5	19.32	30
100	14.75	29.5	47.75
125	23.9	48.5	83
150	33.75	67	106

### MATERIALS LIST

No	Parts Name	Cast Steel
1	Body	Cast Iron
2	Cover	Cast Iron
3	Gasket	NBR/EPDM/PTFE
4	Screen	SS304/316
5	Bolting	Steel
6	Drain Plug	Steel

# BASKET STRAINER FV40-41-SF SERIES

## IRON/BRONZE/STEEL 125LB/150 LB/PN10/PN14/PN21



Swing Bolted Bonnet Version



Bridge Closure

### Flanging To Suit

ANSI 125, 150  
 AS 2129 Table D, E, F  
 AS 4087 PN14, PN21  
 AS 4331.1/EN 1092-1/EN 1092-2/ ISO 7005-1 PN10~25  
 Integral Cast

### STANDARD PRODUCT MATERIAL COMBINATION ANSI CLASS 125/PN10/PN14

Body, Cover, Plug	ASTMA126 Class B Iron
Screens	SS304
Gasket	CNAF/PTFE/EPDM/NBR

### STANDARD PRODUCT MATERIAL COMBINATION ANSI CLASS 150/PN21

Body, Cover, Plug	ASTM B62 - Bronze/A216 WCB
Screens	SS316
Gasket	CNAF/PTFE/NBR/EPDM

Body, Cover, Plug	ASTMA216 Grade WCB
Screens	SS304
Gasket	Non-asbestos (CNAF)

Body, Cover, Plug	ASTMA351 Gr. CF8M
Screens	SS316
Gasket	Non-asbestos (CNAF)

Class 300 model DKSL01 also available

### DIMENSIONS (INCH)

Size (mm)	Size (in)	L	B	C	Blow Off Plug	D Clearance for Bskt Removal	Weight (lb)	Weight (kg)
50	2"	8-1/8	8-3/8	5	1	5-3/8	34	15.42
65	2-1/2"	8-3/4	10	5-5/16	1	6-5/16	43	19.50
80	3"	9-7/8	11-1/4	6-3/4	1	8	60	27.21
100	4"	11-1/2	13-1/2	8	1	9-5/16	120	54.43
125	5"	13-1/8	14-5/8	8-1/6	1	10-1/4	140	63.50
150	6"	14-7/8	15-5/8	8-5/8	1	11-1/8	164	74.39
200	8"	18-11/16	21	11-3/4	1	15-9/16	330	149.69
250	10"	20-1/8	24-1/2	13-3/4	1	18	470	213.19
300	12"	26-1/4	29-3/4	16-3/8	1	23-1/4	820	371.95
350	14"	30-1/4	36-3/8	22-1/4	1-1/2	26-1/4	1300	589.67
400	16"	33-1/8	38-1/4	23-1/4	1-1/2	28-1/8	1600	725.75
450	18"	38-3/8	38	19	3	26-3/4	2260	1025.12
500	20"	41-1/2	43-5/8	23-1/2	3	34-1/8	2980	1351.70

Dimensions are a guide model FV40 and FV41 have different dimensions.

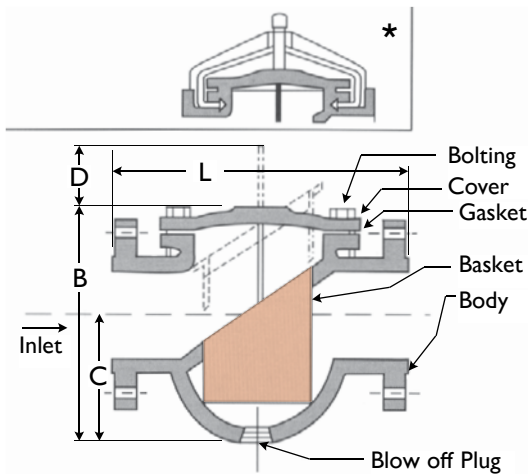

\* Optional quick release lid (Bridge type shown)

SIZE 50NB to 500NB (2"-20")



**AUSTRALIAN PIPELINE VALVE®**

**COMPLETE PRODUCT LINE**

**“Australian Pipeline Valve produces isolation, control and flow reversal protection products for severe and critical service media in utility, steam, pipelines, oil & gas and process industries. APV valves and pipeline products form the most competitive portfolio in the market.”**



**SUPER-CHECK®**



**TORQTURN®**

**TWIN-LOK®**

**UNIFLO®**



**AUSTRALIAN PIPELINE VALVE BRAND RANGE - CATALOGUES**

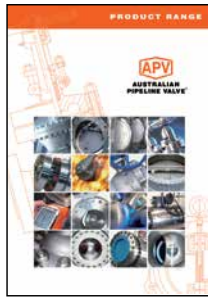

Product Brochure



Ball Valves Floating & Trunnion Mounted

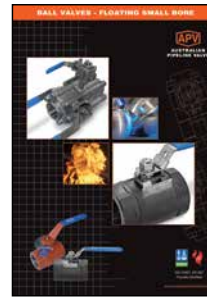

Ball Valves Floating Small Bore

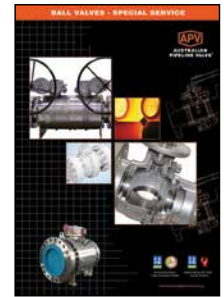

Ball Valves Special Service



Gate, Globe & Check Valves - Cast Steel



Gate, Globe & Check Valves - Forged Steel

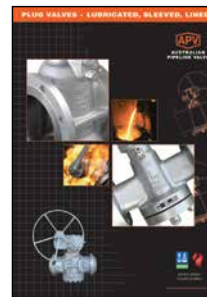

Plug Valves Lubricated, Sleeved & Lined

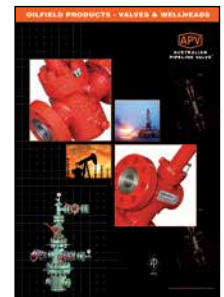

Oilfield Products - Valves & Wellheads

**APV FAMILY OF BRANDS RANGE - CATALOGUES**



Diamond Gear Gearboxes



Flowturn Ball Valves Multiway & Deadman



Flowturn Gate, Globe & Check Valves



Flowturn Instrument Valves

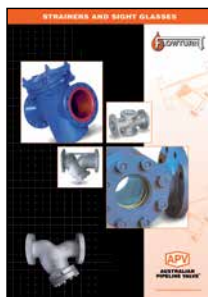

Flowturn Strainers & Sight Glasses



Steamco Steam Valves



Supercheck Wafer Check Valves



Superseal Butterfly Valves

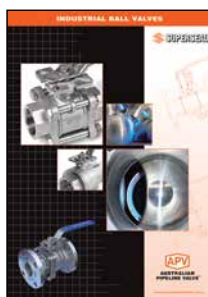

Superseal Industrial Ball Valves



Torqturn Actuators

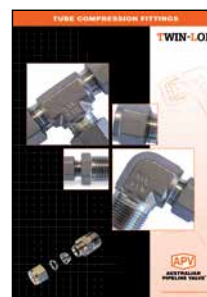

TwinLok Tube Fittings

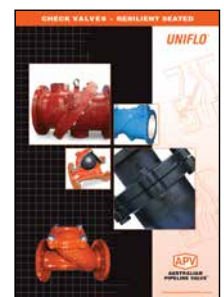

Uniflo Check Valves

Contact us for your local stockist/distributor



# AUSTRALIAN PIPELINE VALVE®

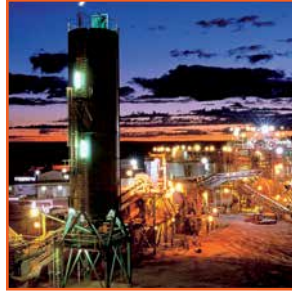

[www.australianpipelinevalve.com.au](http://www.australianpipelinevalve.com.au)

LOCAL DISTRIBUTOR



## QUALITY ASSURANCE AND CERTIFICATION

*We are continually improving all facets of quality assurance. Full metallurgical and test certificates are always supplied for all pressure retaining parts, we also provide it on all major trim components.*

*We have endeavoured to provide a broad outline of our range and capabilities. Because we are continually developing new products for our customers this catalogue will, to some extent be incomplete. This catalogue is a general overview only, individual drawings and data sheets can be furnished on request.*

*If you have any requirement in the field of valves, please contact us for a prompt response. Continuous development of Australian Pipeline Valve products may necessitate changes in the design or manufacturing processes. Australian Pipeline Valve reserves the right to effect any such changes without prior notice.*

