

# PNEUMATIC & HYDRAULIC ACTUATORS

## SHORT VERSION

[Click here](#) for complete version of this catalogue

# TORQTURN®

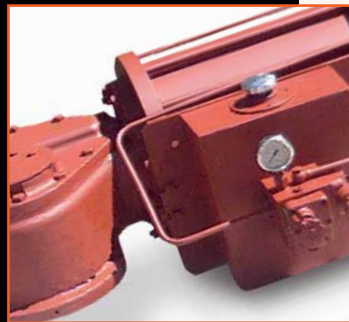
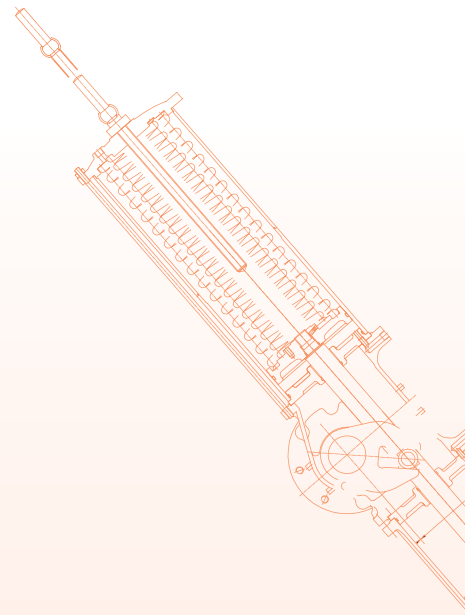

Endurance Test Certified  
SIL2 SIL3



**AUSTRALIAN  
PIPELINE VALVE®**

[www.australianpipelinevalve.com.au](http://www.australianpipelinevalve.com.au)

# QUALITY VALVE MANUFACTURER

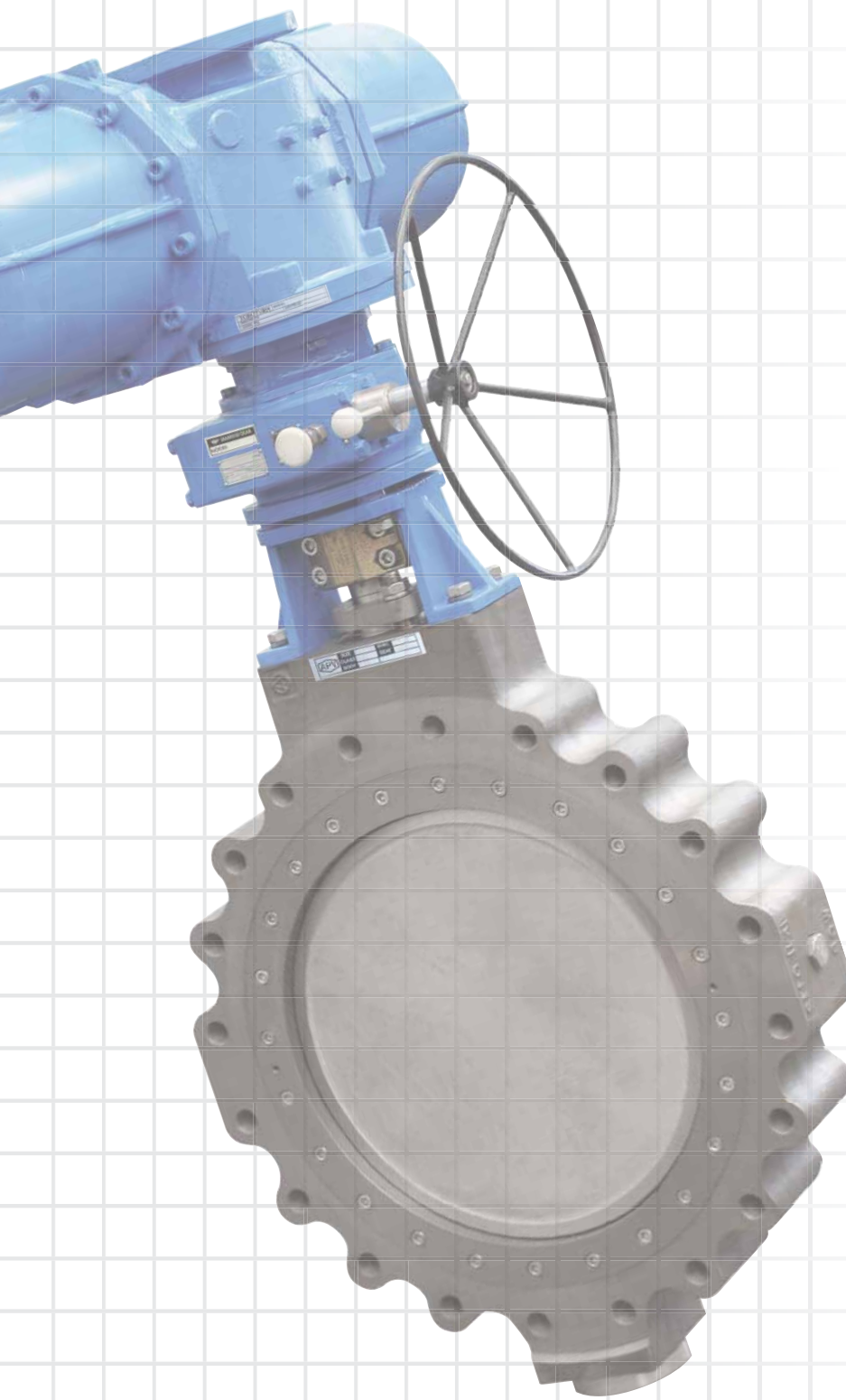

## QUALITY COMMITMENT

*Quality is Our First Priority.*

*Consistent product quality and a proven track record makes Australian Pipeline Valve a dependable choice where total reliability is the number one concern.*

*Since its founding, APV's philosophy has been focused on quality. Our valves are manufactured in full compliance to worldwide standards (such as ASME/ANSI, API, EN, ISO, BS, AS).*



0343 (PED)



II 2 G Dc  
ATEX



**SIL**  
IEC 61508  
SIL-3



**AUSTRALIAN  
PIPELINE VALVE®**

70-78 Stanbel Road Salisbury Plain South Australia 5109

Telephone +61 (0)8 8285 0033

email: [admin@australianpipelinevalve.com.au](mailto:admin@australianpipelinevalve.com.au)

[www.australianpipelinevalve.com.au](http://www.australianpipelinevalve.com.au)

# CONTENTS

Overview JC/JA/SW Series Pneumatic Actuators	5*
JC Series Pneumatic Actuators Specifications & Drawings	6~8*
JA Series Pneumatic Actuators Specifications & Drawings	9~12*
JA/JC Series Pneumatic Actuators Torque Chart	13~14*
SW Series Pneumatic Actuators Specifications & Drawings	15~18*
SW Series Pneumatic Actuators Torque Chart	19*
GP/GH Series Pneumatic & Hydraulic Actuators Specifications & Drawings	20~48*
A-SK Series Pneumatic Actuators Specifications & Drawings	50~53*
RP Series Pneumatic Compact Actuators	54~63*
Compact Quad Pneumatic Actuators	64~78*
ZT Series Linear Pneumatic Actuators	75~76*
Electro - Pneumatic Positioner	79~81*
Electric Actuators	82~84*
Intelligent Electric Actuators	85*

\* This version excludes some of these pages, refer to full version at website.



© Copyright Australian Pipeline Valve 1990 - 2023 Edition

Catalogues, photos, brochures and technical publications are the exclusive property of Australian Pipeline Valve. Any unauthorised reproduction in total or in part, shall result in prosecution. Products and data sheets in this publication are subject to change at anytime without notice. Australian Pipeline Valve reserves the right to carry out amendments to products and materials.

**JA SERIES DOUBLE ACTING  
JA130, JA170, JA200, JA280**

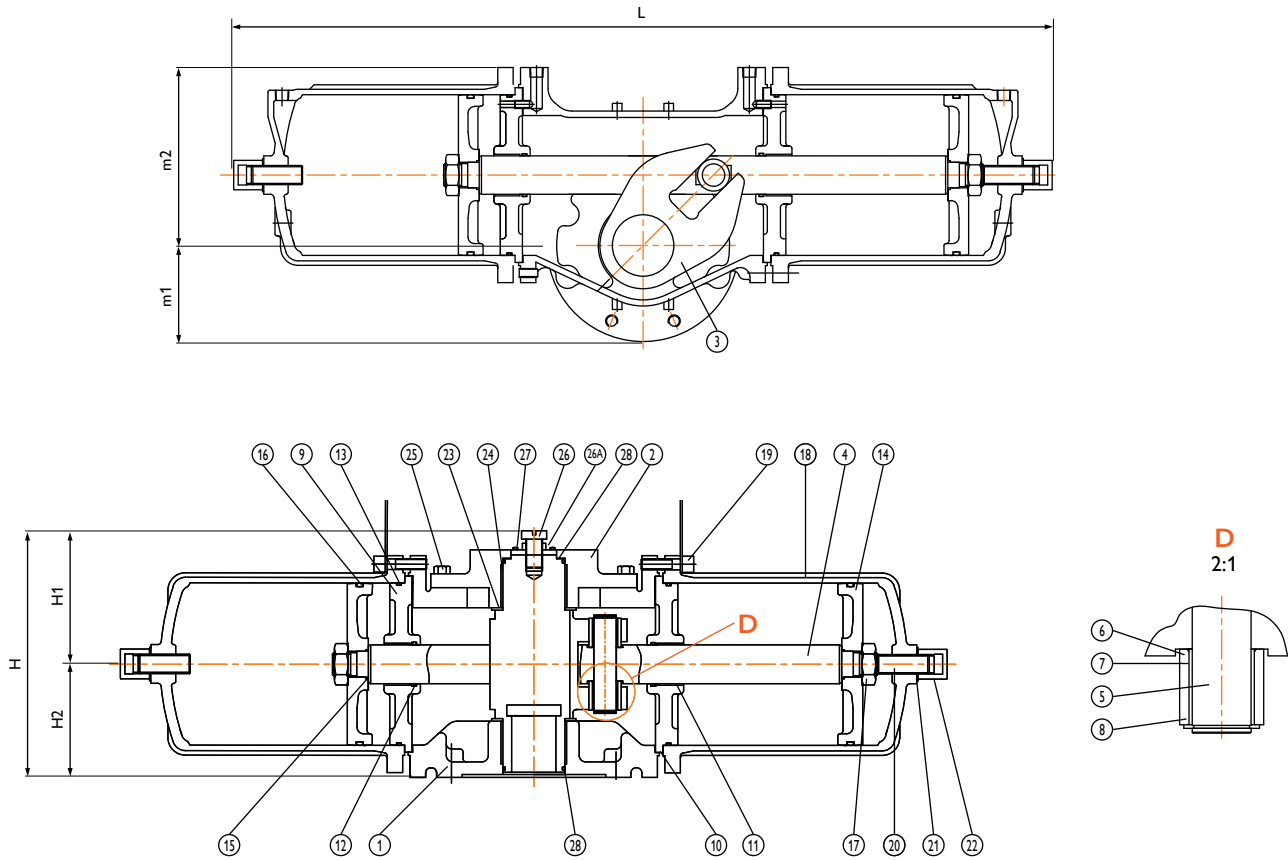

No.	Part Name	Material
1	Body	FCD450
2	Body Cap	FCD450
3	Para Arm	FCD450
4	Piston Rod	S45C
5	Pin	S45C
6	Roller	S45C
7	Bearing	304+PTFE
8	Snap Ring	65Mn
9	Adapter	FC200
10	Gasket	T-1995
11	Bearing	304+PTFE
12	O-Ring	Viton
13	O-Ring	Viton
14	Piston	FC200

No.	Part Name	Material
15	O-Ring	Viton
16	O-Ring	Viton
17	Nut	SS400
18	Cylinder	FCD450+PTFE Lined
19	Cap Screw	SCM435
20	Stopper Bolt	SCM435
21	Gasket	304+Viton
22	Adjustable Cap Nut	SS400
23	Thrust Bearing	RPTFE
24	Bearing	304+PTFE
25	Bolt	SCM435
26	Position Indicator	304
26A	Indicator Arrow Plate	304
27	Feedback Roller Nut	304
28	O-Ring	Viton

Cylinder Size	m1	M2	L	H	H1	H2	Wt (Kg)	Flange ISO 5211
JA-130	68	132	640	188	103	85	60	F14
JA-170	95	176	755	381	209	105	80	F16
JA-200	115	232	1060	457	244	130	130	F25
JA-280	158	302	1360	578	305	165	250	F30

# JA SERIES SPRING RETURN JA130S, JA170S, JA200S, JA280S

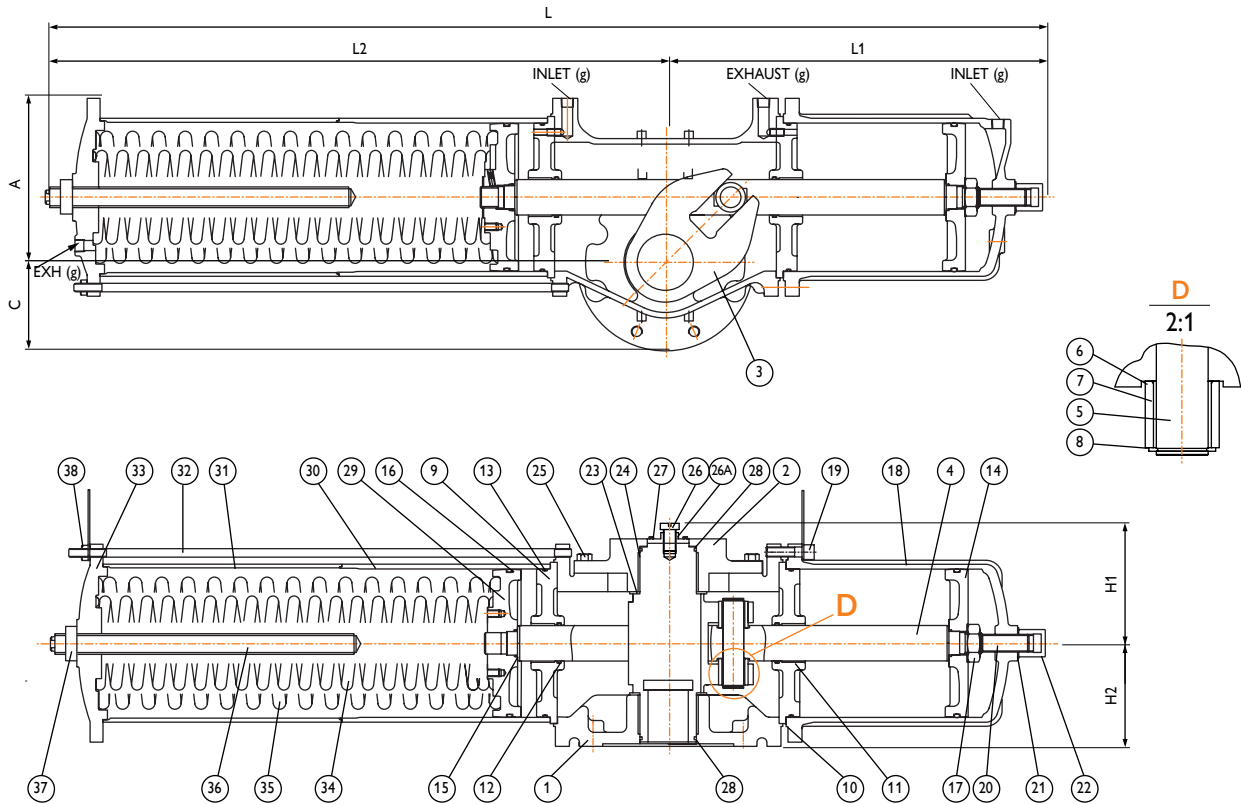

No.	Part Name	Material
1	Body*	FCD450
2	Body Cap	FCD450
3	Para Arm	FCD450
4	Piston Rod	S45C + HCr
5	Pin	S45C
6	Roller	S45C
7	Bearing	304+PTFE
8	Snap Ring	65Mn
9	Adaptor	FC200
10	Gasket	T-1995
11	Bearing	304+PTFE
12	O-Ring	Viton
13	O-Ring	Viton
14	Piston	FC200
15	O-Ring	Viton
16	O-Ring	Viton
17	Nut	SS400
18	Cylinder	FCD450* + PTFE Lined
19	Cap Screw	SCM435

No.	Part Name	Material
20	Stopper Bolt	SCM435
21	Gasket	304 + Viton
22	Cap Nut	SS400 + ENP
23	Thrust Bearing	R.PTFE
24	Bearing	304 + PTFE
25	Bolt	SCM435
26	Position Indicator	304
26A	Indicator Arrow Plate	304
27	Feedback Roller Nut	304
28	O-Ring	Viton
29	Spring Retainer	FCD450
30	Cylinder	Carbon Steel + PTFE Lined
31	Spring Case*	Carbon Steel + PTFE Lined
32	Long Bolt	S45C
33	Spring Cover*	FCD450
34	Spring	60Si2Mn
35	Spring	60Si2Mn
36	Limit Stud	S45C + ENP
37	Adjusting Nut	S45C + ENP
38	Tie Bar Nut	Alloy Steel 2H

\* 3 Coat paint system

Cylinder Size	L	L1	L2	A	C	H1	H2	g	Flange ISO 5211
JA-130S	843	320	523	132	68	103	85	1/4"	F14
JA-170S	988	378	610	176	95	129	116	3/8"	F16
JA-200S	1415	530	885	232	115	152	130	3/8"	F25
JA-280S	1840	680	1160	302	158	188	175	1/2"	F30



# JA SERIES SPRING RETURN MANUAL OVER-RIDE

JA130SH, JA170SH, JA200SH, JA280SH C/W HANDWHEEL - MANUAL OVER-RIDE

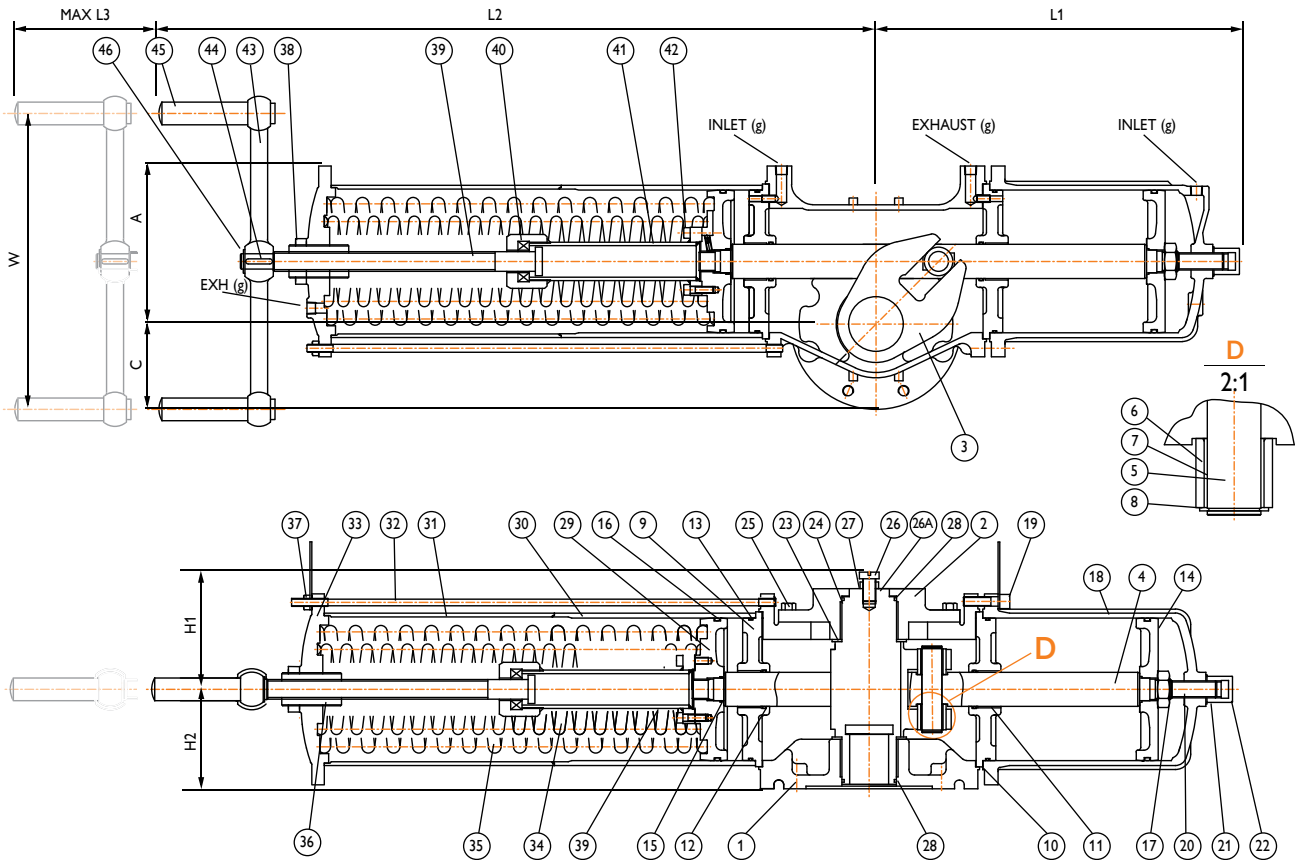

No.	Part Name	Material
1	Body*	FCD450
2	Body Cap*	FCD450
3	Para Arm/Yoke	FCD450
4	Piston Rod	S45C+HCr (AISI 1045)
5	Pin	S45C
6	Roller	S45C
7	Bearing	304+PTFE
8	Snap Ring	65Mn
9	Adaptor	FC200
10	Gasket	T-1995
11	Bearing	304+PTFE
12	O-Ring	Viton
13	O-Ring	Viton
14	Piston	FC200
15	O-Ring	Viton
16	O-Ring	Viton
17	Nut	SS400
18	Cylinder*	FCD450+PTFE Lined
19	Cap Screw	SCM435
20	Stopper Bolt	SCM435
21	Gasket	304+Viton
22	Cap Nut	SS400+ENP
23	Thrust Bearing	RPTFE

No.	Part Name	Material
24	Bearing	304+PTFE
25	Bolt	SCM435
26	Position Indicator	304
26A	Indicator Arrow Plate	304
27	Feedback Roller Nut	304
28	O-Ring	Viton
29	Spring Retainer	FCD450
30	Cylinder*	Carbon Steel + PTFE Lined
31	Spring Case*	Carbon Steel + PTFE Lined
32	Long Bolt	S45C
34	Spring	60Si2Mn
35	Spring	60Si2Mn
36	Limit Stud	S45C+ENP
37	Nut	2H
38	Nut	S45C+ENP
39	Stem Screw	S45C+ENP
40	Bearing	Assembly
41	Bearing Sleeve	A283M (Gr) C
42	Bolt	S45C
43	Handwheel	FCD450
44	Key	S45C
45	Handle	S45C+ZN
46	Snap Ring	65Mn

\*3 Coat Paint System

Cylinder Size	L1	L2	L3	A	C	H1	H2	g	W	Flange ISO 5211
JA-130SH	320	523	130	132	68	103	85	1/4"	250	F14
JA-170SH	378	700	150	176	95	129	116	3/8"	260	F16
JA-200SH	530	960	240	232	115	152	130	3/8"	440	F25
JA-280SH	680	1250	300	302	158	188	177	1/2"	760	F30

## G RANGE GP & GH ACTUATORS

### ADVANTAGES

#### Corrosion Protected

O-Rings are fitted on body caps and all joints. This ensures an effective seal to prevent ingress of water. With one way vent checks, total O-Ring sealing, the model GP and GH design prevents water ingress and seals out the environment. Also the Air/Hydraulic cylinder is PTFE lined. Tie-bars on power module are corrosion resistant, and internal and external surfaces are coated to protect in harsh environments.

#### ISO Valve Mounting

The G Range Actuators interface meets ISO 5011 standard, and meets the dimensional requirements of ISO defined for each torque range.

#### Standardised Interface

The shaft driven accessory interface conforms to NAMUR and are identical on all G Range models, allowing standardisation of accessory mounting hardware and installation practices.

#### Wear Resistant

The guide rod and piston rod have an advanced surface treatment, which combined with self-lubricating bearings, provides superior wear resistance and extends the life of all sliding components. PTFE air/hydraulic cylinder lining ensures long life and smooth running.

#### High Efficiency

The piston rod and guide block connection have superior surface finishes and self-lubricating bearings to maximise input

energy transfer directly to the valve stem. Efficiency is further enhanced by the tension - loaded spring, minimising radial loads on the piston rod.

#### Bidirectional Travel Stops

Integral bidirectional travel stops, adjustable from 80° to 100° of total valve travel prevents excessive valve seat wear.

#### Long Service Life

The G Range actuators incorporate four stages of internal and external coatings to resist severe weather, chemical and petroleum environments. The inner surface of the air cylinder is coated with PTFE providing enhanced corrosion resistance and self-lubrication.

#### Modular Design

G Range actuators design provides field serviceable drive, power, spring and over-ride modules. The modules are removable, serviceable and inter-changeable without the need to remove the actuator from the valve. Modules are available for separate purchase to reduce spare parts inventory.

#### Spring Module

To ensure the safety of personnel during installation and maintenance, the spring module has been designed so that it can only be removed from the power module with the spring in the fully extended position.

This prevents accidental release of the spring force, protecting personnel from injury and the actuator from accidental damage.



Pneumatic Model GP Spring Return



High Pressure Hydraulic Model GH Spring Return



Pneumatic Model GP Double Acting

### GENERAL APPLICATION

#### Torque Outputs

Double acting: 830~250,000 Nm  
Spring return end torques: 307~71764 Nm

#### Operating Temperatures

Standard: -20°C~80°C  
Low Temperature: -40°C~80°C  
High Temperature: -20°C~120°C

#### Operating Pressures

Pneumatic: 3~7 Bar  
Hydraulic: 70~200 Bar

### SPRING RETURN

#### Symmetric or Canted (Inclined) Yokes

Torqturn G-Range actuators are available with either symmetric or canted yokes. The traditional symmetric yokes provide efficient operation at both the 'end to close' and 'break to open' positions. Canted yokes provide higher 'break to open' torques and are used where lower 'run' and 'end' torques are acceptable. Torqturn actuators utilise the optimal solution depending on actuator size.



Symmetrical Yoke



Canted Yoke

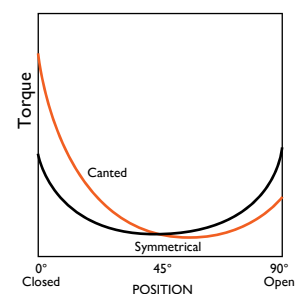

## G RANGE GP & GH ACTUATORS

### DESIGN FEATURES OFFER UNIQUE BENEFITS

**1. Safe Spring Lock**

Positively locks the spring module in place under load. Prevents spring module detachment from the drive module.

**2. Reduced Wear**

The design of connection between the piston rod and the guide block compensates for side load deflection and there by reduces wear on the rod, bearings and seals.

**3. Standardised Mounting**

The NAMUR mounting configuration allows standardisation of mounting hardware for a wide range of shaft driven accessories.

**4. Replaceable Bearings**

Replaceable bearings protect sliding and rotating components, with suitability for either dry or lubricated working conditions.

**5. Coated Guide Bar**

PTFE thrust bar prevents yoke pin axial movement, transferring axial loads directly to the drive module case.

**6. Optional Over-ride**

Internal hydraulic over-ride cylinder module for spring-return models doesn't increase actuator length.

**7. Ease of Lifting**

G25 and larger models are equipped with four lifting eyes for safe actuator handling during shipping installation and removal.

**8. Integral Housing Vent**

The main actuator housing incorporates an integral check valve in order to release overpressure.

### MODEL GP PNEUMATIC

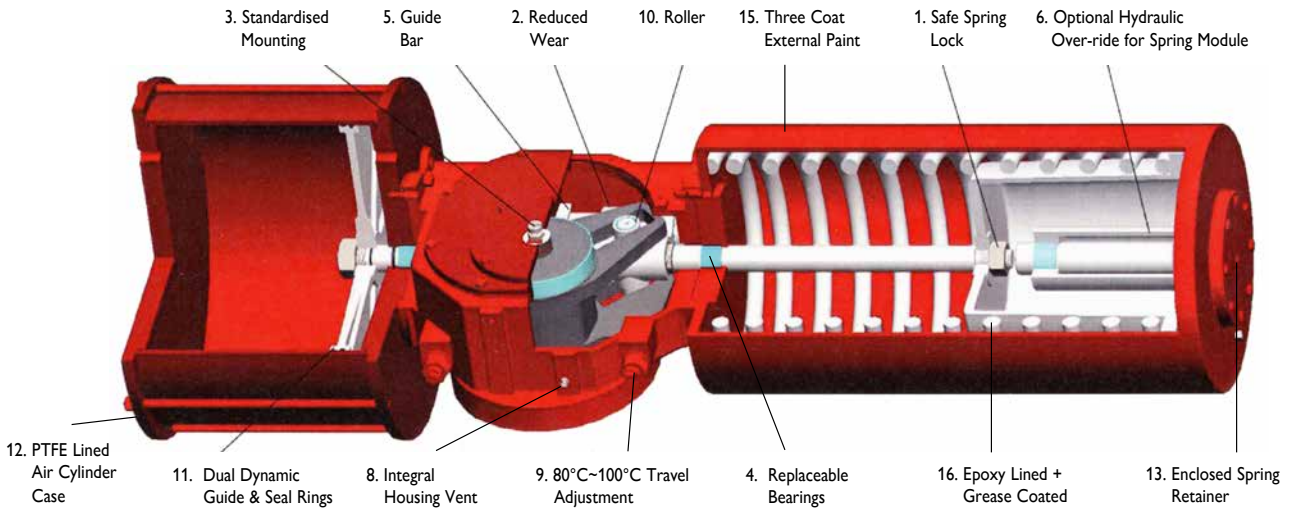

### MODEL GH HYDRAULIC

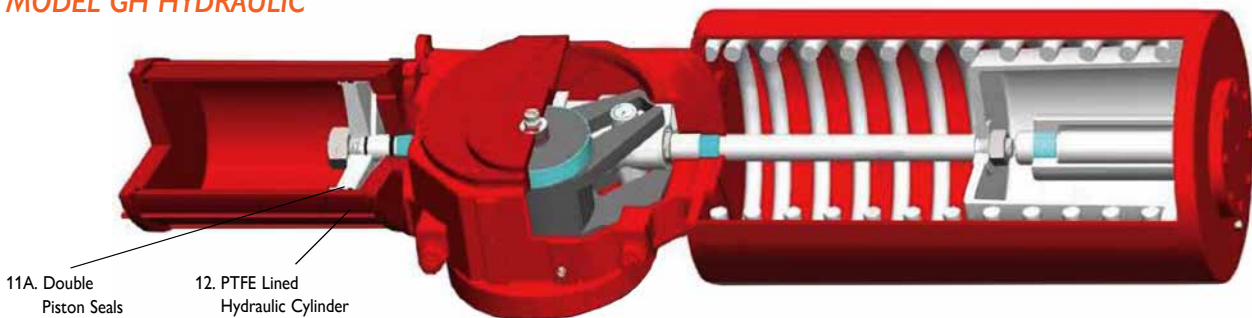

**9. 80°~100° Travel Adjustment**

Bi-directional travel stops are integral to the actuator. The stops allow 80° ~ 100° total travel adjustment and are designed to prevent ingress of foreign matter and water.

**10. Roller**

Rollers are used which reduces friction between the yoke arm and pin, minimising wear to the yoke arm and pin.

**11. PTFE Guide Ring**

The PTFE Guide prevents metal to metal contact with the cylinder bore, thus ensuring the cylinder is not damaged by the piston whilst also reducing torque as well as ensuring ease of operation.

**11A. Double Piston Seals**

Hydraulic cylinders have double sealing with o-ring and dynamic seal ring to prevent metal to metal contact between cylinder and piston.

**12. PTFE Lined Cylinder**

The Air/Hydraulic Cylinder is PTFE lined to ensure smooth low torque operation over the life of the actuator and also prevent corrosion.

**13. Spring Safety**

The retaining nut system & cover positively locks and covers the spring module to allow its safe removal and installation, eliminating accidental release of the spring force.



# G RANGE - MODEL GP PNEUMATIC ACTUATORS

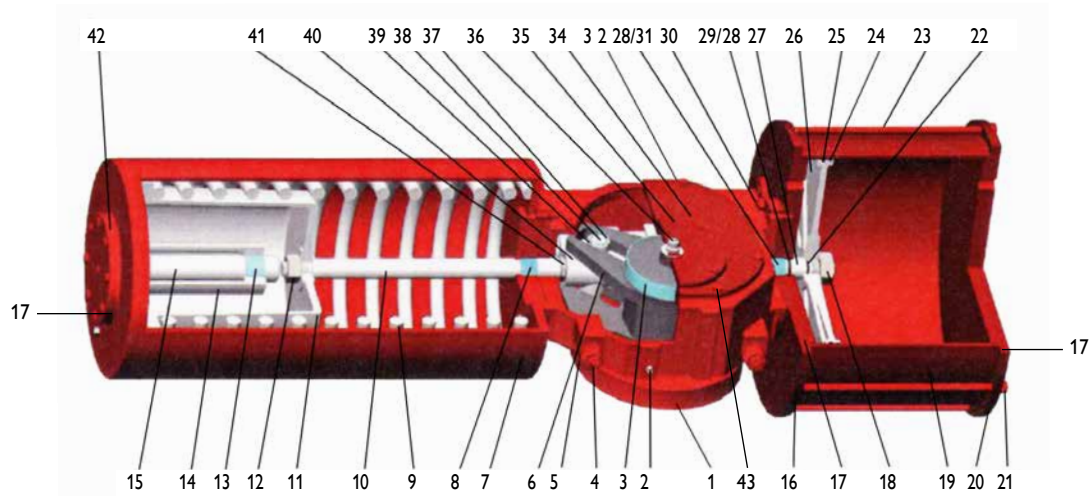

## ASSEMBLY DRAWING - MATERIALS LIST - SPRING RETURN

No.	Name	Material	No.	Name	Material
1	Body	Ductile Iron +3 Coat Paint	23	Screw	Alloy Steel
2	Vent Valve	Carbon Steel	24	Dynamic Guide Ring	PTFE / Viton
3	Sliding Bearing	Metal + PTFE	25	O-Ring	Viton / NBR
4	Adjust Stud	Alloy Steel	26	Piston	Ductile Iron
5	Nut	2H	27	Centre Bar	Alloy Steel
6	Yoke	Carbon Steel	28	O-Ring	Viton / NBR
7	Spring Case	Carbon Steel* Epoxy Lined + Grease Coated	29	Stud	Alloy Steel
8	Sliding Bearing	Metal + PTFE	30	Nut	2H
9	Spring	Alloy Steel	31	Sliding Bearing	Metal + PTFE
10	Tension Rod	Alloy Steel	32	Bolt	Carbon Steel
11	Spring Seat	Carbon Steel	33	Body Cap	Ductile Iron
12	Nut	2H	34	Bolt	Carbon Steel
13	Sliding Bearing	Metal + PTFE	35	Cover	Ductile Iron
14	Hydraulic Cylinder	Carbon Steel	36	Drive Shaft	Alloy Steel
15	Hydraulic Piston	Carbon Steel	37	Roller	Alloy Steel
16	Adaptor	Ductile Iron	38	Sliding Bearing	Metal + PTFE
17	O-Ring	Viton / NBR	39	Pin	Alloy Steel
18	Nut	2H	40	Guide Block	Ductile Iron
19	Cylinder	Carbon Steel + PTFE Lined	41	Nut	Carbon Steel
20	End Cap	Ductile Iron	42	Cover Plate	Carbon Steel
21	Tie Bar** & Nut	Alloy Steel* / 2H	43	O-Ring	Viton / NBR
22	O-Ring	Viton / NBR			

\* Or Ductile Iron in smaller sizes. \*\* Stainless Steel or no external tie option available. Sample only, refer to as built B.O.M for each size.

**G RANGE - MODEL GP DIMENSIONS - SR3~SR6**

**SPRING RETURN ACTING**

Indicative dimensions only, refer to as built drawing as dimensions vary according to configuration.

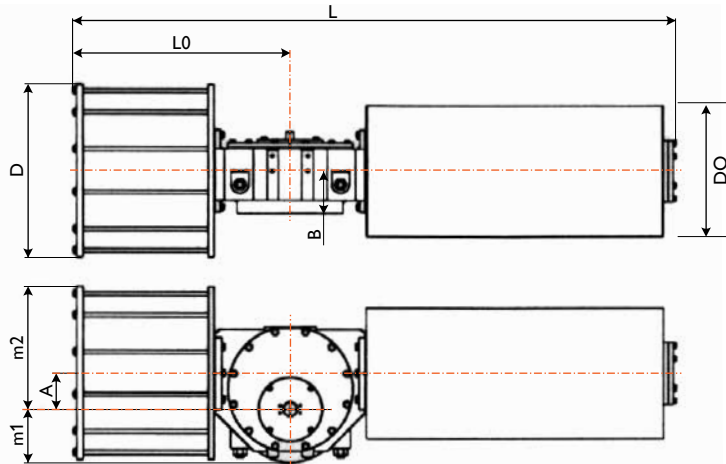

Model	Flange	L	L0	m1	m2	A	B	D	DO	Air Port	Weight (kg)
GP12S-170 SR3~6	F12	962	364	65	165	50	80	230	*	RC3/8"	79
GP12S-200 SR3~6		962	364	78	178	50	80	256	*	RC3/8"	93
GP14S-200 SR3~6	F14	1105	449	87.5	187.5	60	88	255	*	RC3/8"	117
GP14S-250 SR3~6		1105	449	87.5	212.5	60	88	305	*	RC1/2"	156
GP14S-300 SR3~6		1125	449	87.5	237.5	60	88	360	*	RC1/2"	182
GP16S-250 SR3~6	F16	1289	499	105	222.5	70	92	305	*	RC1/2"	184
GP16S-300 SR3~6		1289	499	105	247.5	70	92	360	*	RC1/2"	209
GP16S-350 SR3~6		1318	499	105	272.5	70	92	415	*	RC1/2"	268
GP25S-350 SR3~6	F25	1576	556	150	292.5	90	104	415	*	RC1/2"	316
GP25S-400 SR3~6		1576	556	150	317.5	90	104	465	*	RC3/4"	355
GP25S-450 SR3~6		1674	556	150	350	90	104	520	*	RC3/4"	386
GP30S-450 SR3~6	F30	1807	662	175	370	110	130	520	*	RC3/4"	534
GP30S-500 SR3~6		1807	662	175	395	110	130	570	*	RC3/4"	609
GP30S-550 SR3~6		1807	662	175	420	110	130	620	*	RC3/4"	758
GP35S-550 SR3~6	F35	2005	817	207.5	450	140	165	620	*	RC3/4"	997
GP35S-600 SR3~6		2005	817	207.5	450	140	165	670	*	RC1"	1102
GP35S-700 SR3~6		2005	817	207.5	475	140	165	770	*	RC1"	1310
GP40S-600 SR3~6	F40	2695	960	237.5	505	170	200	670	*	RC1"	1230
GP40S-700 SR3~6		2695	960	237.5	555	170	200	770	*	RC1"	1420
GP40S-800 SR3~6		2695	960	237.5	607.5	170	200	875	*	RC1.1/2"	1865
GP48S-800 SR3~6	F48	3395	1130	280	637.5	200	210	875	*	RC1.1/2"	2340
GP48S-900 SR3~6		3395	1130	280	687.5	200	210	975	*	RC2"	2816
GP48S-1000 SR3~6		3585	1130	280	787.5	200	210	1075	*	RC2"	3380
GP60S-800 SR3~6	F60	4185	1380	343	707.5	270	230	875	*	RC1.1/2"	3170
GP60S-900 SR3~6		4185	1380	343	757.5	270	230	975	*	RC2"	3718
GP60S-1000 SR3~6		4750	1380	343	807.5	270	230	1075	*	RC2"	4230
GP60S-1100 SR3~6		4750	1380	343	857.5	270	230	1175	*	RC2"	4940

General overview only, refer to drawing for dimensions. \*Refer to drawing.

# G RANGE - MODEL GP TORQUE CHARTS - SR6

## SPRING RETURN TORQUES (Nm) - SPRING SIZE/AIR SUPPLY 4.5 BAR

Model	Max Torque of Drive Module	Air Start (BTO)	Run (Air)	Air End (ETO)	Spring Break (BTC)	Run (Spring)	Spring End (ETC)
GP10S-150 SR6	550 Nm	202.5	84.5	79.5	383.0	193.0	260.0
GP10S-170 SR6		279.5	116.0	108.5	489.0	242.0	319.0
GP12S-170 SR6	1000 Nm	384.0	182.0	222.0	526.0	267.0	364.0
GP12S-200 SR6		-	-	-	818.0	407.0	541.0
GP14S-200 SR6	2000 Nm	689.5	240.0	234.5	1028.0	512.0	623.0
GP14S-250 SR6		-	-	-	1477.0	752.0	948.0
GP14S-300 SR6		-	-	-	2291.0	1162.0	1458.0
GP16S-250 SR6	4000 Nm	-	-	-	1896.0	968.0	1227.0
GP16S-300 SR6		1637.0	819.0	669.5.0	2595.0	1310.0	1629.0
GP16S-350 SR6		2041.0	1258.5	689.0	3858.0	1954.0	2446.0
GP25S-350 SR6	8000 Nm	-	-	-	4955.0	2466.0	2999.0
GP25S-400 SR6		-	-	-	6326.0	3117.0	3726.0
GP25S-450 SR6		-	-	-	8261.0	4024.0	4720.0
GP30S-450 SR6	16000 Nm	5500.0	2694.5	2185.5	9375.0	4712.0	5824.0
GP30S-500 SR6		7402.0	3666.0	3236.5	11426.0	5741.0	7092.0
GP30S-550 SR6		-	-	-	14080.0	6952.0	8344.0
GP35S-550 SR6	32000 Nm	-	-	-	18185.0	8970.0	10752.0
GP35S-600 SR6		-	-	-	22471.0	10908.0	12716.0
GP35S-700 SR6		19256.0	8856.0	6243.0	28953.0	14335.0	17288.0
GP40S-600 SR6	63000 Nm	15731.0	7870.0	6422.5	26630.0	13472.0	16828.0
GP40S-700 SR6		21741.5	10331.5	7885.5	35425.0	17702.0	21679.0
GP40S-800 SR6		23829.5	10601.5	7925.5	47742.0	23883.0	29300.0
GP48S-800 SR6	125000 Nm	-	-	-	57348.0	28690.0	35200.0
GP48S-900 SR6		43606.5	19909.0	13504.5	69602.0	34788.0	42618.0
GP48S-1000 SR6		53088.0	21284.0	21464.5	82680.0	41743.0	51976.0
GP60S-800 SR6	250000 Nm	-	-	-	78878.0	39710.0	49217.0
GP60S-900 SR6		-	-	-	95891.0	47761.0	58177.0
GP60S-1000 SR6		68279.0	34639.5	31528.5	112369.0	57081.0	71764.0

**BTO** = Break To Open Torque (Air Start)  
**RUN** = Running Minimum (Half-Stroke Torque)  
**ETO** = End To Open Torque (Air End)  
**BTC** = Break To Close Torque (Spring Start)  
**ETC** = End To Close Torque (Spring End)

## G RANGE - MODEL GP TORQUE CHARTS - SR5

## SPRING RETURN TORQUES (Nm) - SPRING SIZE/AIR SUPPLY 5.0 BAR

Model	Max Torque of Drive Module	Air Start (BTO)	Run (Air)	Air End (ETO)	Spring Break (BTC)	Run (Spring)	Spring End (ETC)
GP12S-170 SR5	1000 Nm	489	245	330	485	243	326
GP12S-200 SR5		688	337	448	698	343	453
GP14S-200 SR5	2000 Nm	877	456	594	789	402	506
GP14S-250 SR5		1347	671	818	1345	670	815
GP14S-300 SR5		1908	975	1235	1880	957	1206
GP16S-250 SR5	4000 Nm	1692	881	1150	1553	795	1011
GP16S-300 SR5		2438	1213	1472	2421	1202	1455
GP16S-350 SR5		3215	1744	2106	3194	1637	2085
GP25S-350 SR5	8000 Nm	3826	2044	2400	3960	2013	2534
GP25S-400 SR5		5309	2685	3352	4955	2466	2999
GP25S-450 SR5		6788	3402	4188	6326	3117	3726
GP30S-450 SR5	16000 Nm	7892	4001	4922	7929	3968	4869
GP30S-500 SR5		10042	5125	6490	9375	4712	5824
GP30S-550 SR5		12106	6162	7772	11426	5741	7092
GP35S-550 SR5	32000 Nm	15527	7909	9984	14449	7241	8907
GP35S-600 SR5		18327	9058	10894	18185	8971	10752
GP35S-700 SR5		25470	12767	15715	23864	11772	14109
GP40S-600 SR5	63000 Nm	21644	11014	13884	21426	10879	13666
GP40S-700 SR5		29304	14679	18046	30015	15120	18757
GP40S-800 SR5		41095	21218	27349	35425	17702	21679
GP48S-800 SR5	125000 Nm	44755	22574	28063	45789	23214	29097
GP48S-900 SR5		58269	29261	36121	57348	28690	35200
GP48S-1000 SR5		72776	36756	45792	69602	34789	42618
GP60S-800 SR5	250000 Nm	61439	30300	36302	63398	31515	38261
GP60S-900 SR5		76967	38524	47305	78878	39710	49217
GP60S-1000 SR5		97605	48824	59891	95891	47761	58177
GP60S-1100 SR5		116733	59787	76127	112369	57081	71764

**BTO** = Break To Open Torque (Air Start)  
**RUN** = Running Minimum (Half-Stroke Torque)  
**ETO** = End To Open Torque (Air End)  
**BTC** = Break To Close Torque (Spring Start)  
**ETC** = End To Close Torque (Spring End)

**G RANGE - MODEL GP DIMENSIONS**

DOUBLE ACTING

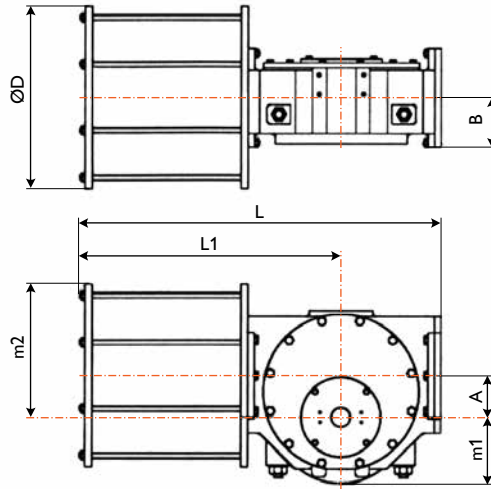

Model	Flange	L	L1	m1	m2	A	B	D	Air Port	Weight (kg)
GP12S-170DA	F12	499	364	73	165	50	80	230	RC3/8"	41
GP12S-200DA		499	364	73	178	50	80	256	RC3/8"	48
GP14S-200DA	F14	594	449	87.5	187.5	60	88	255	RC3/8"	57
GP14S-250DA		594	449	87.5	212.5	60	88	305	RC1/2"	69
GP14S-300DA		594	449	87.5	237.5	60	88	360	RC1/2"	87
GP16S-250DA	F16	679	499	105	222.5	70	92	305	RC1/2"	89
GP16S-300DA		679	499	105	247.5	70	92	360	RC1/2"	108
GP16S-350DA		679	499	105	272.5	70	92	415	RC1/2"	129
GP25S-350DA	F25	766	556	150	292.5	90	104	415	RC1/2"	158
GP25S-400DA		766	556	150	317.5	90	104	465	RC3/4"	202
GP25S-450DA		766	556	150	350	90	104	520	RC3/4"	223
GP30S-450DA	F30	922	662	175	370	110	130	520	RC3/4"	285
GP30S-500DA		922	662	175	395	110	130	570	RC3/4"	325
GP30S-550DA		922	662	175	420	110	130	620	RC3/4"	351
GP35S-550DA	F35	1130	817	207.5	450	140	165	620	RC3/4"	427
GP35S-600DA		1130	817	207.5	450	140	165	670	RC1"	463
GP35S-700DA		1130	817	207.5	475	140	165	770	RC1"	542
GP40S-600DA	F40	1320	960	237.5	505	170	200	670	RC1"	636
GP40S-700DA		1320	960	237.5	555	170	200	770	RC1"	723
GP40S-800DA		1320	960	237.5	607.5	170	200	875	RC1.1/2"	842
GP48S-800DA	F48	1580	1130	280	637.5	200	210	875	RC1.1/2"	1073
GP48S-900DA		1580	1130	280	687.5	200	210	975	RC2"	1335
GP48S-1000DA		1580	1130	280	787.5	200	210	1075	RC2"	1560
GP60S-800DA	F60	1960	1380	343	707.5	270	230	875	RC1.1/2"	1685
GP60S-900DA		1960	1380	343	757.5	270	230	975	RC2"	1970
GP60S-1000DA		1960	1380	343	807.5	270	230	1075	RC2"	2210
GP60S-1100DA		1960	1380	343	857.5	270	230	1175	RC2"	2510



## G RANGE - MODEL GP TORQUE CHARTS

### DOUBLE ACTING TORQUES (Nm)

Model	Max Torque of Drive Module	Air Pressure															
		3 Bar		4 Bar		4.5 Bar		5 Bar		5.5 Bar		6 Bar		7 Bar		8 Bar	
		Start End	Run	Start End	Run	Start End	Run	Start End	Run	Start End	Run	Start End	Run	Start End	Run	Start End	Run
GP10S-150DA	500 Nm	309	185	412	247	464	278	515	309	567	340	618	370	812	487	928	494
GP10S-170DA		400	240	533	320	599	360	666	400	732	439	800	480	1048	630	1198	640
GP12S-170DA	1000 Nm	499	300	666	400	749	449	832	499	916	549	998	600	1311	786	1498	800
GP12S-200DA		695	417	927	556	1043	626	1159	695	1275	765	1390	834	1825	1096	2086	1112
GP14S-200DA	2000 Nm	831	499	1108	665	1247	748	1385	831	1524	914	1662	998	2182	1309	2494	1330
GP14S-250DA		1351	810	1801	1081	2026	1216	2251	1351	2476	1486	2702	1620	3546	2128	4052	2162
GP14S-300DA		1955	1173	2607	1564	2933	1760	3258	1955	3584	2151	3910	2346	5133	3080	5866	3128
GP16S-250DA	4000 Nm	1682	1009	2243	1346	2523	1514	2804	1682	3084	1850	3364	2018	4415	2650	5046	2692
GP16S-300DA		2437	1462	3250	1950	3656	2194	4062	2437	4469	2681	4874	2924	6398	3840	7312	3900
GP16S-350DA		3312	1987	4416	2649	4968	2981	5520	3312	6072	3643	6624	3974	8694	5217	9936	5298
GP25S-350DA	8000 Nm	3956	2373	5274	3165	5934	3560	6593	3956	7252	4351	7912	4746	10385	6230	11868	6330
GP25S-400DA		5036	3022	6715	4029	7554	4532	8393	5036	9233	5540	10072	6044	13220	7931	15108	8058
GP25S-450DA		6387	3832	8516	5110	9581	5748	10645	6387	11710	7026	12774	7664	16767	10059	19162	10220
GP30S-450DA	16000 Nm	7790	4674	10387	6232	11685	7011	12983	7790	14282	8569	15580	9348	20449	12269	23370	12464
GP30S-500DA		9636	5781	12848	7709	14454	8672	16059	9636	17665	10599	19272	11562	25295	15176	28908	15418
GP30S-550DA		11676	7005	15568	9341	17514	10508	19460	11676	21405	12843	23352	14010	30650	18389	35028	18682
GP35S-550DA	32000 Nm	14811	8886	19747	11848	22216	13329	24684	14811	27153	16292	29622	17772	38878	23326	44432	23696
GP35S-600DA		17654	10593	23539	14123	26481	15889	29424	17654	32366	19420	35308	21186	46342	27806	52962	28246
GP35S-700DA		24083	14450	32111	19267	36125	21675	40139	24083	44153	26492	48166	28900	63219	37931	72250	38534
GP40S-600DA	63000 Nm	21325	12795	28433	17060	31987	19192	35541	21325	39095	23457	42650	25590	55977	33586	63974	34120
GP40S-700DA		29131	17479	38842	23305	43697	26218	48552	29131	53408	32045	58262	34958	76470	45882	87394	46610
GP40S-800DA		38139	22884	50852	30511	57209	34325	63566	38139	69922	41953	76278	45768	100116	60069	114418	61022
GP48S-800DA	125000 Nm	44819	26891	59758	35855	67228	40337	74698	44819	82167	49300	89638	53782	117649	70590	134456	71710
GP48S-900DA		56829	34097	75772	45463	85244	51146	94715	56829	104187	62512	113658	68194	149177	89506	170488	90926
GP48S-1000DA		70253	42152	93670	56202	105379	63227	117088	70253	128796	77278	140506	84304	184413	110647	210758	112404
GP60S-800DA	250000 Nm	60269	36161	80359	48215	90404	54242	100448	60269	110493	66296	120538	72322	158207	94924	180808	96430
GP60S-900DA		76483	45890	101978	61187	114725	68835	127472	76483	140219	84132	152966	91780	200769	120461	229450	122374
GP60S-1000DA		94605	56763	126140	75684	141907	85144	157675	94605	173442	104065	189210	113526	248337	149002	283814	151368
GP60S-1100DA		114634	68781	152846	91707	171951	103171	191057	114634	210163	126098	229268	137562	300914	180549	343902	183414

**G RANGE - PART NUMBER SYSTEM**



Endurance Test Certified

GP	30	S	-	500	SR	5	V	-	HW	STC
①	②	③		④	⑤	⑥	⑦		⑧	⑨

**① Actuator Type**

GP = Pneumatic
GH = Hydraulic

**② Centre Body Size**

10
12
14
16
25
30
35
40
48
60

**③ Yoke Type**

S = Symmetric
C = Canted

**④ Cylinder Size**

40	170	450
50	190	500
60	200	550
70	220	600
80	245	700
90	250	800
100	270	900
110	300	1000
120	320	1100
130	350	
150	400	

**⑤ Acting Type**

DA = Double Acting
SR = Single Acting

**⑥ Spring Size**

1
2
3
4
5
5.5
6

**⑦ Temperature**

L = Low Temperature (HNBR) (-45~80°C)
M = Mid Temperature (NBR) (-25~100°C)
V = High Temperature (Viton) (-20~130°C)

**⑧ Special Code**

HW = Jack Screw Manual Over-ride
EX = Extended Travel Stop
HY = Hydraulic Over-ride
MG = Manual Gear Over-ride

**⑨ Air Failure Position\***

STC = Spring to Close
STO = Spring to Open

\*Only applicable to single acting spring return



# A-SK SERIES PNEUMATIC ACTUATOR

'CB' STYLE PISTON TYPE SCOTCH YOKE

## FEATURES AND BENEFITS

- Scotch yoke design using precision bearings eliminates the usual dead zone present in other yoke mechanisms, providing the maximum torque output at beginning and end of stroke.
- Travel stops located at the centre of the piston rod eliminates side loading to the output shaft.
- ISO 5211 standard mounting.
- Top of the actuators have NAMUR mounting design, for ease of mounting limit switch and positioner
- A-SK series actuators are available with different shafts on request (male or female)

## MODEL CODE SYSTEM

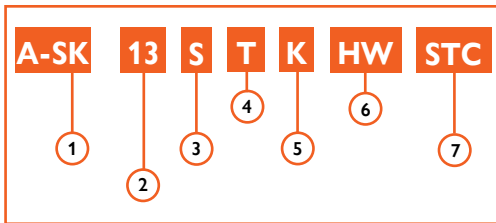

### 1. Type

A-SK - yoke structure model prefix

### 2. Model Suffix

A-SK 07, A-SK 09, A-SK 10, A-SK 12, A-SK 13

### 3. Features

- D - Double acting, pressure: 0.3 ~ 0.7MPa
- S - Spring Return pressure: 0.4 ~ 0.7MPa
- L - Spring Return (low pressure) pressure: 0.29 ~ 0.39MPa

### 4. Special specification

- A - Standard
- B - Stainless steel nut and bolt
- C - Control
- F - High frequency
- K - High temperature ( 0 ~ 120°C)
- M - Manual over-ride
- T - Low temperature ( -45 ~ 60°C)
- Q - High speed

## TECHNICAL DATA

- Maximum supply pressure** 0.7MPa
- Rated supply pressure** 0.4 ~ 0.7MPa
- Temperature**
  - Standard** 20°C to 80°C
  - Optional** 45°C to 120°C mounting
- Angular rotation** 90 degrees ± 10 degrees

## GENERAL APPLICATION

A-SK series actuators are normally used for remote control of any quarter-turn application: ball, butterfly, rotary plug or damper style valves, etc. Used in oil and gas, chemical process, food and beverage, iron and steel, off-shore marine, pharmaceutical, power, pulp and paper, and textile industries.



### 5. Output type

- S - Shaft output (male)
- K - Hole output (female)

### 6. Manual over-ride (option)

- H - for double acting with manual lever
- HG - for double acting with manual gear
- HW - for spring return with outside wheel

### 7. Position when air fails

- STC - air fail valve close
- STO - air fail valve open



Endurance Test Certified

## RANGE OF SUPPLY (A-SK SERIES)

Type	Model					
	Double Acting			Single Acting		
	Standard	Low Temp.	High Temp.	Standard	Low Temp.	High Temp.
Scotch Yoke	A-SK07	A-SK07T	A-SK07K	A-SK07S	A-SK07ST	A-SK07SK
	A-SK10	A-SK10T	A-SK10K	A-SK10S	A-SK10ST	A-SK10SK
	A-SK12	A-SK12T	A-SK12K	A-SK12S	A-SK12ST	A-SK12SK
	A-SK15	A-SK15T	A-SK15K	A-SK15S	A-SK15ST	A-SK15SK

# A-SK SERIES

## TORQUE CHARACTERISTICS

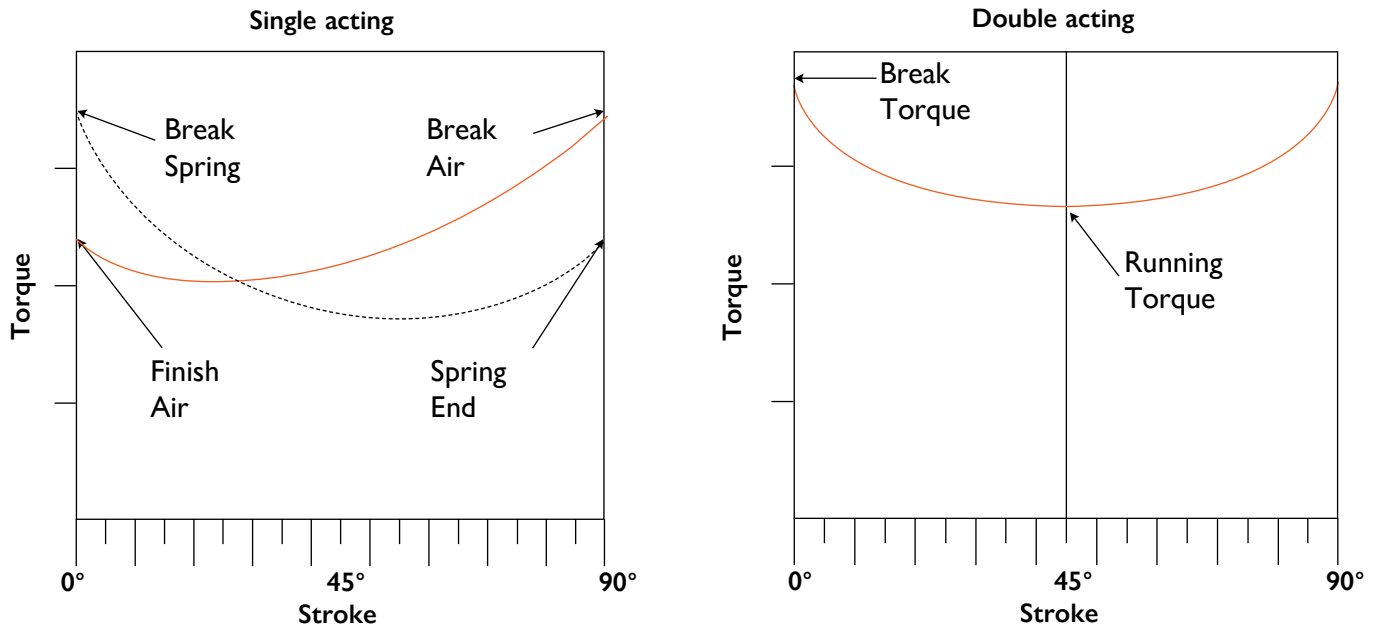

### OUTPUT TORQUE (Nm) single acting - SPRING RETURN

Model	Output Torque of Spring			Air Pressure																	
				0.4MPa Air			0.45MPa Air			0.5MPa Air			0.55MPa Air			0.6MPa Air			0.7MPa Air		
	Spring Break	Spring Run	Spring Break	Air Break	Air Run	Air End	Air Break	Air Run	Air End	Air Break	Air Run	Air End	Air Break	Air Run	Air End	Air Break	Air Run	Air End	Air Break	Air Run	Air End
A-SK10SR4	93	45	56	94	46	57	113	57	76	132	69	94	151	80	113	170	91	132	207	114	170
A-SK10SR5	109	52	64	86	38	41	105	50	60	124	61	79	143	73	97	161	84	116	199	107	154
A-SK10SR6	122	60	77	73	30	28	92	42	47	111	53	65	129	65	84	148	76	103	186	99	141
A-SK12SR4	185	96	131	207	109	152	249	134	195	291	160	237	334	186	279	376	212	321	461	263	406
A-SK12SR5	275	135	169	168	70	62	211	96	105	253	121	147	295	147	189	338	173	232	422	224	316
A-SK12SR6	337	159	188	149	45	0	192	71	43	234	91	85	276	122	127	319	148	170	403	199	254
A-SK15SR4	321	151	178	319	150	177	382	188	239	444	226	301	506	264	363	569	302	426	693	377	550
A-SK15SR5	379	190	246	252	112	118	314	150	181	376	188	243	439	226	306	501	264	368	626	339	492
A-SK15SR6	442	235	289	206	83	53	269	123	116	331	163	178	393	203	240	455	243	302	579	323	426

### OUTPUT TORQUE (Nm) DOUBLE ACTING

Model		Air Pressure			
		3.0 Bar	4.0 Bar	5.0 Bar	6.0 Bar
A-SK07	Break & End	60	80	100	120
	Running	36	48	60	72
A-SK10	Break & Endg	85	158	197	237
	Running	51	94	117	141
A-SK12	Break & End	266	362	452	543
	Running	158	217	271	325
A-SK15	Break & End	412	534	667	801
	Running	246	320	406	480

**A-SK SERIES - DOUBLE ACTING**

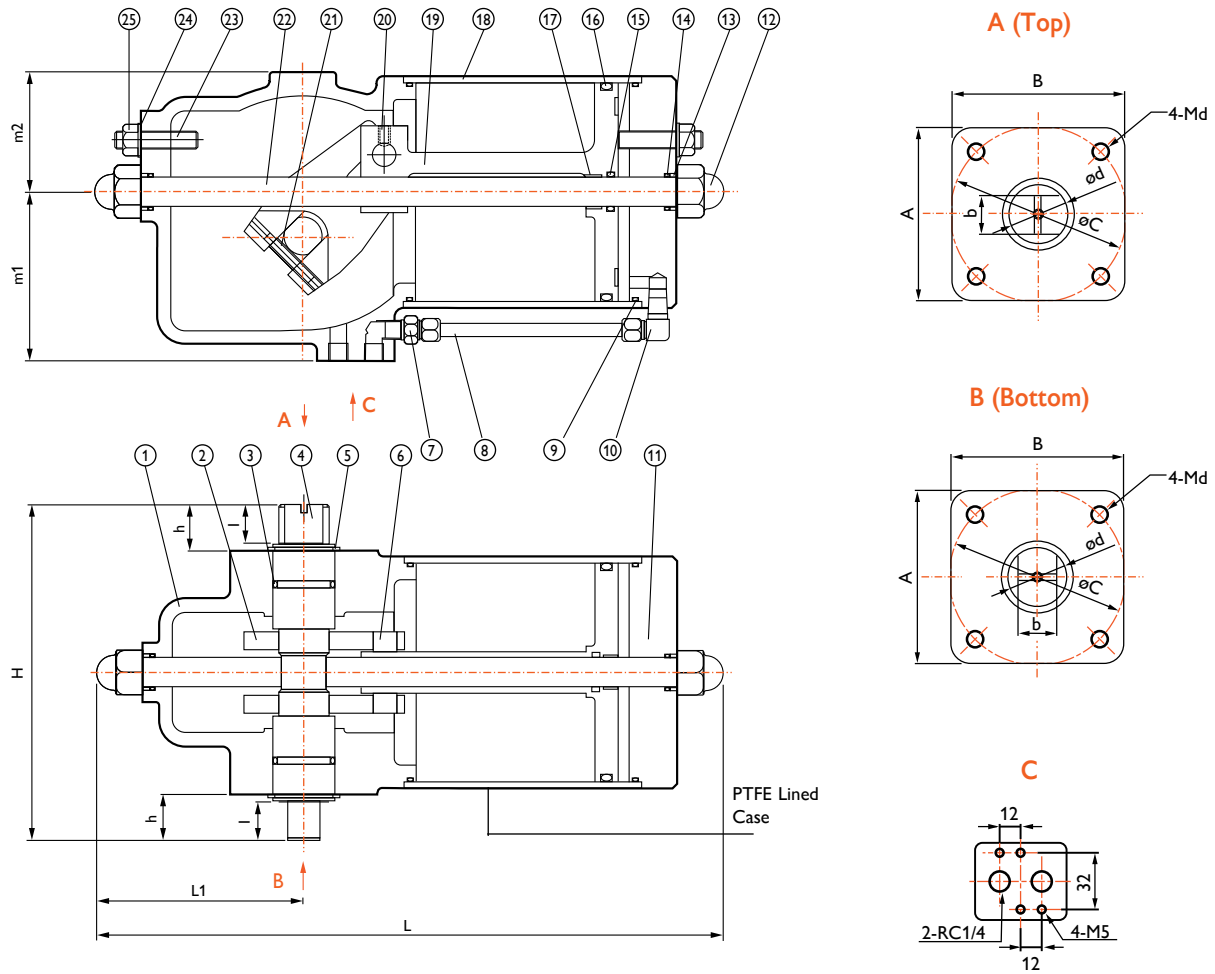

**DIMENSIONS**

Torque Cylinder	L	L1	I	H	h	d	b	C	A	B	m1	m2	Md
A-SK07	310	100	18	171	23.5	20	12	70	100	70	53	75	M8
A-SK10	310	100	22	147	25.5	27	17	70	100	70	68	90	M8
A-SK12	424	140	26	202	31	34	22	202	100	100	71	113	M10
A-SK15	424	140	26	227	31	34	22	202	100	100	85	113	M10

**MATERIALS**

No.	Part Name	Material
1	Body	HT200
2	Para Arm	QT450-10
3	Stem	45 HCr
4	O-Ring	Viton
5	Snap Ring	65Mn
6	Pin	45
7	Connector	304
8	Pipe	304
9	O-Ring	Viton
10	Connector	304
11	Cylinder Cap	25
12	Cap Nut	Q235
13	Washer	304

No.	Part Name	Material
14	O-Ring	Viton
15	O-Ring	Viton
16	O-Ring	Viton
17	Bearing	304+PTFE
18	Cylinder	20
19	Piston	QT450-10
20	Screw	45
21	Pin	45
22	Piston Rod	304
23	Stopper Bolt	45
24	Gasket	304+Viton
25	Nut	2H





**AUSTRALIAN PIPELINE VALVE®**

**COMPLETE PRODUCT LINE**

**“Australian Pipeline Valve produces isolation, control and flow reversal protection products for severe and critical service media in utility, steam, pipelines, oil & gas and process industries. APV valves and pipeline products form the most competitive portfolio in the market.”**



**SUPER-CHECK®**



**TORQTURN®**

**TWIN-LOK®**

**UNIFLO®**



**AUSTRALIAN PIPELINE VALVE BRAND RANGE - CATALOGUES**

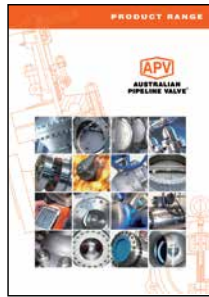

Product Brochure



Ball Valves Floating & Trunnion Mounted

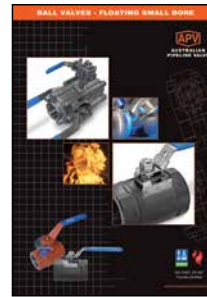

Ball Valves Floating Small Bore

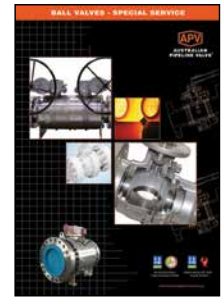

Ball Valves Special Service



Gate, Globe & Check Valves - Cast Steel



Gate, Globe & Check Valves - Forged Steel

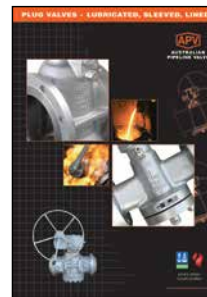

Plug Valves Lubricated, Sleeved & Lined

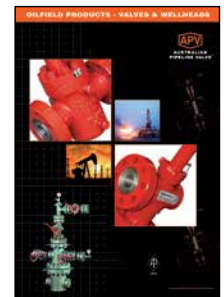

Oilfield Products - Valves & Wellheads

**APV FAMILY OF BRANDS RANGE - CATALOGUES**



Diamond Gear Gearboxes



Flowturn Ball Valves Multiway & Deadman



Flowturn Gate, Globe & Check Valves



Flowturn Instrument Valves



Flowturn Strainers & Sight Glasses



Steamco Steam Valves



Supercheck Wafer Check Valves



Superseal Butterfly Valves

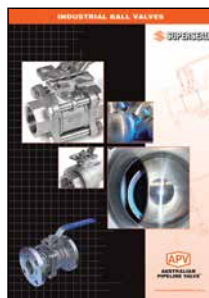

Superseal Industrial Ball Valves



Torqturn Actuators

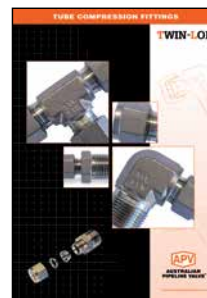

TwinLok Tube Fittings

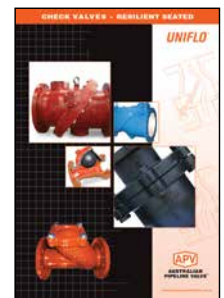

Uniflo Check Valves

Contact us for your local stockist/distributor



# AUSTRALIAN PIPELINE VALVE®

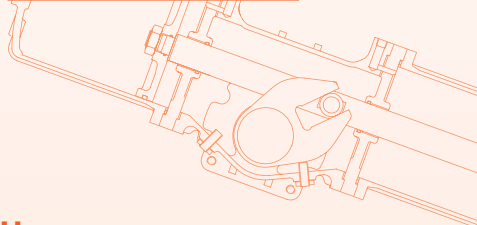

[www.australianpipelinevalve.com.au](http://www.australianpipelinevalve.com.au)

LOCAL DISTRIBUTOR



AS 4629



Endurance Test Certified

## QUALITY ASSURANCE AND CERTIFICATION

*We are continually improving all facets of quality assurance. Full metallurgical and test certificates can be supplied.*

*We have endeavoured to provide a broad outline of our range and capabilities. Because we are continually developing new products for our customers this catalogue will, to some extent be incomplete. This catalogue is a general overview only, individual drawings and data sheets can be furnished on request.*

*If you have any requirement in the field of valves and fittings, please contact us for a prompt response. Continuous development of Australian Pipeline Valve products may necessitate changes in the design or manufacturing processes. Australian Pipeline Valve reserves the right to effect any such changes without prior notice.*

