

(17)

Table II-4 Dimensions of Facings (Other Than Ring Joints, All Pressure Rating Classes)

1	2	3	4	5	6	7	8	9	10	11	12	13	14	15
Nominal Pipe Size	Outside Diameter				Inside Diameter of Large and Small Tongue, U	Inside Diameter of Small Male [Note (1)]	Outside Diameter			Inside Diameter of Large and Small Groove, Z	Height		Minimum Outside Diameter of Raised Portion [Notes (6), (7)]	
	Raised Face Large Male and Large Tongue, R	Small Male, S [Note (1)]	Small Tongue, T	Large Female and Large Groove, W			Small Female, X [Note (1)]	Small Groove, Y	Raised Face [Notes (2), (3)]		Large and Small Tongue [Notes (2), (4)]	Depth of Groove or Female [Notes (2), (5)]	Small Female and Groove, K	Large Female and Groove, L
1/2	1.38	0.72	1.38	1.00	...	1.44	0.78	1.44	0.94	1.75	1.81
3/4	1.69	0.94	1.69	1.31	...	1.75	1.00	1.75	1.25	2.06	2.12
1	2.00	1.19	1.88	1.50	...	2.06	1.25	1.94	1.44	2.25	2.44
1 1/4	2.50	1.50	2.25	1.88	...	2.56	1.56	2.31	1.81	2.62	2.94
1 1/2	2.88	1.75	2.50	2.12	...	2.94	1.81	2.56	2.06	2.88	3.31
2	3.62	2.25	3.25	2.88	...	3.69	2.31	3.31	2.81	3.62	4.06
2 1/2	4.12	2.69	3.75	3.38	...	4.19	2.75	3.81	3.31	4.12	4.56
3	5.00	3.31	4.62	4.25	...	5.06	3.38	4.69	4.19	5.00	5.44
3 1/2	5.50	3.81	5.12	4.75	...	5.56	3.88	5.19	4.69	5.50	5.94
4	6.19	4.31	5.69	5.19	...	6.25	4.38	5.75	5.12	6.19	6.62
5	7.31	5.38	6.81	6.31	...	7.38	5.44	6.88	6.25	7.31	7.75
6	8.50	6.38	8.00	7.50	...	8.56	6.44	8.06	7.44	8.50	8.94
8	10.62	8.38	10.00	9.38	...	10.69	8.44	10.06	9.31	10.62	11.06
10	12.75	10.50	12.00	11.25	...	12.81	10.56	12.06	11.19	12.75	13.19
12	15.00	12.50	14.25	13.50	...	15.06	12.56	14.31	13.44	15.00	15.44
14	16.25	13.75	15.50	14.75	...	16.31	13.81	15.56	14.69	16.25	16.69
16	18.50	15.75	17.62	16.75	...	18.56	15.81	17.69	16.69	18.50	18.94
18	21.00	17.75	20.12	19.25	...	21.06	17.81	20.19	19.19	21.00	21.44
20	23.00	19.75	22.00	21.00	...	23.06	19.81	22.06	20.94	23.00	23.44
22	25.25
24	27.25	23.75	26.25	25.25	...	27.31	23.81	26.31	25.19	27.25	27.69

GENERAL NOTES:

- (a) Dimensions are in inches.
(b) For facing requirements for flanges and flanged fittings, see paras. 6.3 and 6.4 and Figure II-6.
(c) For facing requirements for lapped joints, see para. 6.4.3 and Figure II-6.
(d) For facing tolerances, see para. 7.3.



(17)

Table II-4 Dimensions of Facings (Other Than Ring Joints, All Pressure Rating Classes) (Cont'd)

NOTES:

- (1) For small male and female joints, care should be taken in the use of these dimensions to ensure that the inside diameter of fitting or pipe is small enough to permit sufficient bearing surface to prevent the crushing of the gasket. This applies particularly where the joint is made on the end of the pipe. The inside diameter of the fitting should match the inside diameter of the pipe as specified by the purchaser. Threaded companion flanges for small male and female joints are furnished with plain face and are threaded with American National Standard Locknut Thread (NPSL).
- (2) See para. 6.4.3 and Figure II-6 for thickness and outside diameters of laps.
- (3) The height of the raised face is either 0.06 in. or 0.25 in. (see para. 6.4.1).
- (4) The height of the large and small male and tongue is 0.25 in.
- (5) The depth of the groove or female is 0.19 in.
- (6) The raised portion of the full face may be furnished unless otherwise specified on order.
- (7) Large male and female faces and large tongue and groove are not applicable to Class 150 because of potential dimensional conflicts.

(17)

Table II-10 Templates for Drilling Class 300 Pipe Flanges and Flanged Fittings

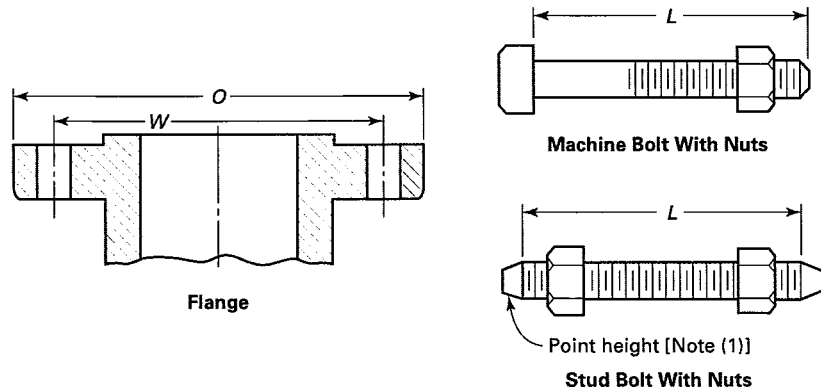

Nominal Pipe Size	Outside Diameter of Flange, <i>O</i>	Drilling [Notes (2), (3)]				Length of Bolts, <i>L</i> [Note (4)]		
		Diameter of Bolt Circle, <i>W</i>	Diameter of Bolt Holes	Number of Bolts	Diameter of Bolts	Stud Bolts [Note (1)]		Machine Bolts
						Raised Face 0.06 in.	Ring Joint	Raised Face 0.06 in.
1/2	3.75	2.62	5/8	4	1/2	2.50	3.00	2.25
3/4	4.62	3.25	3/4	4	5/8	3.00	3.50	2.50
1	4.88	3.50	3/4	4	5/8	3.00	3.50	2.50
1 1/4	5.25	3.88	3/4	4	5/8	3.25	3.75	2.75
1 1/2	6.12	4.50	7/8	4	3/4	3.50	4.00	3.00
2	6.50	5.00	3/4	8	5/8	3.50	4.00	3.00
2 1/2	7.50	5.88	7/8	8	3/4	4.00	4.50	3.25
3	8.25	6.62	7/8	8	3/4	4.25	4.75	3.50
3 1/2	9.00	7.25	7/8	8	3/4	4.25	5.00	3.75
4	10.00	7.88	7/8	8	3/4	4.50	5.00	3.75
5	11.00	9.25	7/8	8	3/4	4.75	5.25	4.25
6	12.50	10.62	7/8	12	3/4	4.75	5.50	4.25
8	15.00	13.00	1	12	7/8	5.50	6.00	4.75
10	17.50	15.25	1 1/8	16	1	6.25	6.75	5.50
12	20.50	17.75	1 1/4	16	1 1/8	6.75	7.25	5.75
14	23.00	20.25	1 1/4	20	1 1/8	7.00	7.50	6.25
16	25.50	22.50	1 3/8	20	1 1/4	7.50	8.00	6.50
18	28.00	24.75	1 3/8	24	1 1/4	7.75	8.25	6.75
20	30.50	27.00	1 3/8	24	1 1/4	8.00	8.75	7.25
22	33.00	29.25	1 5/8	24	1 1/2	9.00	10.00	8.00
24	36.00	32.00	1 5/8	24	1 1/2	9.00	10.00	8.00

GENERAL NOTES:

- (a) Dimensions are in inches.
- (b) For other dimensions see, Tables II-11 and II-12.

NOTES:

- (1) The length of the stud bolt does not include the height of the points (see para. 6.10.2).
- (2) For flange bolt holes, see para. 6.5.
- (3) For spot facing, see para. 6.6.
- (4) Bolt lengths not shown in the table may be determined in accordance with Nonmandatory Appendix C (see para. 6.10.2).

(17)

Table II-11 Dimensions of Class 300 Flanges

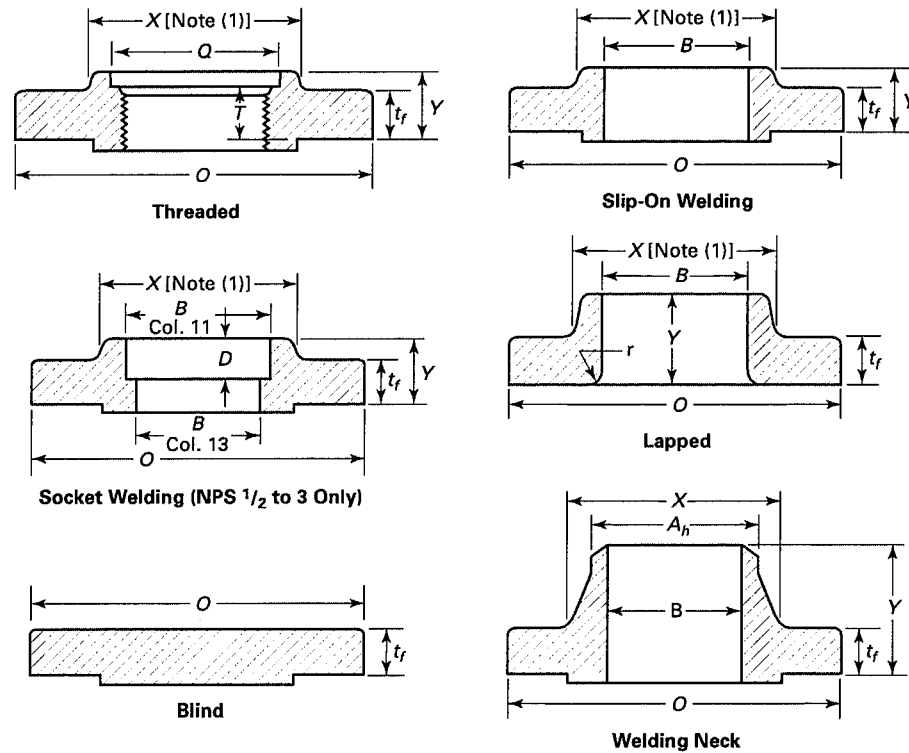

174

ASME B16.5-2017

1	2	3	4	5	6	7	8	9	10	11	12	13	14	15	16	
Nominal Pipe Size	Outside Diameter of Flange, O	Minimum Thickness of Flange, t_f [Notes (2)-(4)]	Thickness of Lap Joint, t_f	Diameter of Hub, X	Diameter Beginning of Chamfer Welding Neck, A_h Note (4)	Length Through Hub			Minimum Thread Length Threaded, T [Note (5)]	Bore			Welding Neck/Socket Welding, B [Note (6)]	Corner Bore Radius of Lapped Flange and Pipe, r	Minimum Counter-bore Threaded Flange, Q	Depth of Socket, D
						Threaded Slip-On Socket Welding, Y	Lapped, Y	Welding Neck, Y		Minimum Slip-On Socket Welding, B	Minimum Lapped, B					
1/2	3.75	0.50	0.56	1.50	0.84	0.81	0.88	2.00	0.62	0.88	0.90	0.62	0.12	0.93	0.38	
3/4	4.62	0.56	0.62	1.88	1.05	0.94	1.00	2.19	0.62	1.09	1.11	0.82	0.12	1.14	0.44	
1	4.88	0.62	0.69	2.12	1.32	1.00	1.06	2.38	0.69	1.36	1.38	1.05	0.12	1.41	0.50	
1 1/4	5.25	0.69	0.75	2.50	1.66	1.00	1.06	2.50	0.81	1.70	1.72	1.38	0.19	1.75	0.56	
1 1/2	6.12	0.75	0.81	2.75	1.90	1.13	1.19	2.63	0.88	1.95	1.97	1.61	0.25	1.98	0.62	
2	6.50	0.81	0.88	3.31	2.38	1.25	1.31	2.69	1.12	2.44	2.46	2.07	0.31	2.50	0.69	

(17)

Table II-11 Dimensions of Class 300 Flanges (Cont'd)

1	2	3	4	5	6	7			10	11		13	14	15	16
						Length Through Hub				Bore					
Nominal Pipe Size	Outside Diameter of Flange, <i>O</i>	Minimum Thickness of Flange, <i>t_f</i> [Notes (2)-(4)]	Thickness of Lap Joint, <i>t_l</i>	Diameter of Hub, <i>X</i>	Diameter Beginning of Chamfer Welding Neck, <i>A_h</i> Note (4)]	Threaded Slip-On Socket Welding, <i>Y</i>	Lapped, <i>Y</i>	Welding Neck, <i>Y</i>	Minimum Thread Length Threaded, <i>T</i> [Note (5)]	Minimum Slip-On Socket Welding, <i>B</i>	Minimum Lapped, <i>B</i>	Welding Neck/ Socket Welding, <i>B</i> [Note (6)]	Corner Bore Radius of Lapped Flange and Pipe, <i>r</i>	Minimum Counter- bore Threaded Flange, <i>Q</i>	Depth of Socket, <i>D</i>
3	8.25	1.06	1.12	4.62	3.50	1.63	1.69	3.06	1.25	3.57	3.60	3.07	0.38	3.63	0.81
3½	9.00	1.12	1.19	5.25	4.00	1.69	1.75	3.13	1.44	4.07	4.10	3.55	0.38	4.13	...
4	10.00	1.19	1.25	5.75	4.50	1.82	1.88	3.32	1.44	4.57	4.60	4.03	0.44	4.63	...
5	11.00	1.31	1.38	7.00	5.56	1.94	2.00	3.82	1.69	5.66	5.69	5.05	0.44	5.69	...
6	12.50	1.38	1.44	8.12	6.63	2.00	2.06	3.82	1.81	6.72	6.75	6.07	0.50	6.75	...
8	15.00	1.56	1.62	10.25	8.63	2.38	2.44	4.32	2.00	8.72	8.75	7.98	0.50	8.75	...
10	17.50	1.81	1.88	12.62	10.75	2.56	3.75	4.56	2.19	10.88	10.92	10.02	0.50	10.88	...
12	20.50	1.94	2.00	14.75	12.75	2.82	4.00	5.06	2.38	12.88	12.92	12.00	0.50	12.94	...
14	23.00	2.06	2.12	16.75	14.00	2.94	4.38	5.56	2.50	14.14	14.18	Note (7)	0.50	14.19	...
16	25.50	2.19	2.25	19.00	16.00	3.19	4.75	5.69	2.69	16.16	16.19	Note (7)	0.50	16.19	...
18	28.00	2.31	2.38	21.00	18.00	3.44	5.12	6.19	2.75	18.18	18.20	Note (7)	0.50	18.19	...
20	30.50	2.44	2.50	23.12	20.00	3.69	5.50	6.32	2.88	20.20	20.25	Note (7)	0.50	20.19	...
22	33.00	2.56	2.62	25.25	22.00	3.94	5.69	6.44	...	22.22	22.25	Note (7)	0.50
24	36.00	2.69	2.75	27.62	24.00	4.13	6.00	6.56	3.25	24.25	24.25	Note (7)	0.50	24.19	...

GENERAL NOTES:

- Dimensions of Table II-11 are in inches.
- For tolerances, see section 7.
- For facings, see para. 6.4.
- For flange bolt holes, see para. 6.5 and Table II-10.
- For spot facing, see para. 6.6.
- For reducing threaded and slip-on flanges, see Table II-6.
- Blind flanges may be made with or without hubs at the manufacturer's option.
- For reducing welding neck flanges, see para. 6.8.

NOTES:

- This dimension is for the large end of the hub, which may be straight or tapered. Taper shall not exceed 7 deg on threaded, slip-on, socket-welding, and lapped flanges. This dimension is defined as the diameter at the intersection between the hub taper and back face of the flange.
- These flanges may be supplied with a flat face. The flat face may be either the full t_f dimension thickness plus 0.06 in. or the t_f dimension thickness without the raised face height. See para. 6.3.2 for additional restrictions.
- The flange dimensions illustrated are for regularly furnished 0.06-in. raised face (except lapped); for requirements of other facings, see Figure II-6.
- For welding end bevel, see para. 6.7.

(17)

Table II-11 Dimensions of Class 300 Flanges (Cont'd)

NOTES (Cont'd):

(5) For thread of threaded flanges, see para. 6.9.

(6) Dimensions in Column 13 correspond to the inside diameters of pipe as given in ASME B36.10M for standard wall pipe. Standard wall dimensions are the same as Schedule 40 in sizes NPS 10 and smaller. Tolerances in para. 7.5.2 apply. These bore sizes are furnished unless otherwise specified by the purchaser.

(7) To be specified by the purchaser.

Table II-12 Dimensions of Class 300 Flanged Fittings

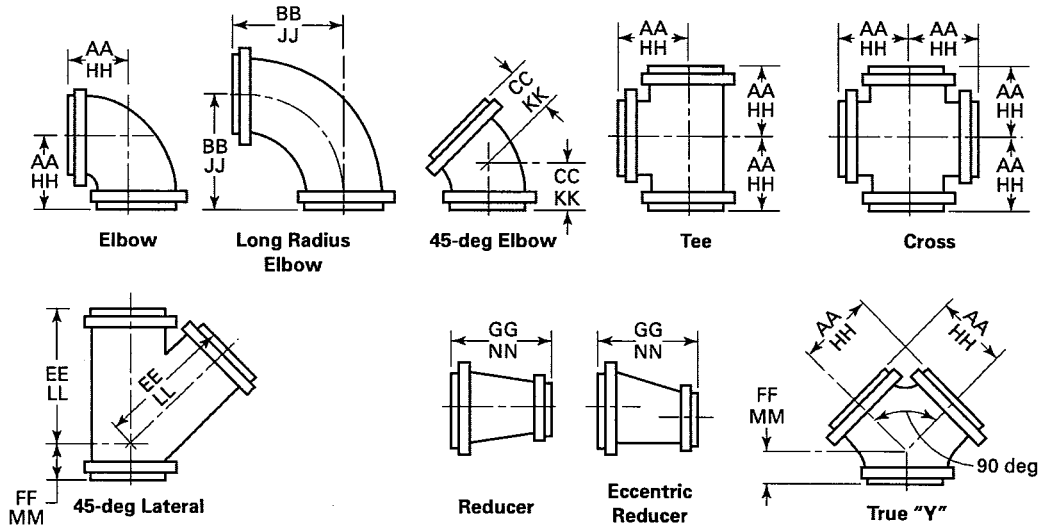

1	2	3	4	5	6	7	8	9	10	11	12
					0.06-in. Raised Face (Flange Edge) [Note (4)]						Ring Joint [Note (4)]
Nominal Pipe Size, NPS	Outside Diameter of Flange, <i>O</i>	Minimum Thickness of Flange, <i>t_f</i> [Notes (1)-(4)]	Minimum Wall Thickness of Fitting, <i>t_m</i>	Inside Diameter of Fitting, <i>d</i>	Center-to-Surface of Raised Face Elbow, Tee, Cross, and True "Y," AA	Center-to-Contact Surface of Raised Face Long Radius Elbow, BB	Center-to-Contact Surface of Raised Face 45-deg Elbow, CC	Long Center-to-Contact Surface of Raised Face Lateral, EE	Short Center-to-Contact Surface of Raised Face Lateral and True "Y," FF	Contact Surface of Raised Face Reducer, GG [Note (5)]	Center-to-End Elbow Tee, Cross, and True "Y," HH [Note (6)]
1	4.88	0.62	0.19	1.00	4.00	5.00	2.25	6.50	2.00	4.50	4.25
1¼	5.25	0.69	0.19	1.25	4.25	5.50	2.50	7.25	2.25	4.50	4.50
1½	6.12	0.75	0.19	1.50	4.50	6.00	2.75	8.50	2.50	4.50	4.75
2	6.50	0.81	0.25	2.00	5.00	6.50	3.00	9.00	2.50	5.00	5.31
2½	7.50	0.94	0.25	2.50	5.50	7.00	3.50	10.50	2.50	5.50	5.81
3	8.25	1.06	0.28	3.00	6.00	7.75	3.50	11.00	3.00	6.00	6.31
3½	9.00	1.12	0.29	3.50	6.50	8.50	4.00	12.50	3.00	6.50	6.81
4	10.00	1.19	0.31	4.00	7.00	9.00	4.50	13.50	3.00	7.00	7.31
5	11.00	1.31	0.38	5.00	8.00	10.25	5.00	15.00	3.50	8.00	8.31
6	12.50	1.38	0.38	6.00	8.50	11.50	5.50	17.50	4.00	9.00	8.81
8	15.00	1.56	0.44	8.00	10.00	14.00	6.00	20.50	5.00	11.00	10.31
10	17.50	1.81	0.50	10.00	11.50	16.50	7.00	24.00	5.50	12.00	11.81
12	20.50	1.94	0.56	12.00	13.00	19.00	8.00	27.50	6.00	14.00	13.31
14	23.00	2.06	0.62	13.25	15.00	21.50	8.50	31.00	6.50	16.00	15.31
16	25.50	2.19	0.69	15.25	16.50	24.00	9.50	34.50	7.50	18.00	10.81
18	28.00	2.31	0.75	17.00	18.00	26.50	10.00	37.50	8.00	19.00	18.31
20	30.50	2.44	0.81	19.00	19.50	29.00	10.50	40.50	8.50	20.00	19.89
24	36.00	2.69	0.94	23.00	22.50	34.00	12.00	47.50	10.00	24.00	22.94

Table II-12 Dimensions of Class 300 Flanged Fittings (Cont'd)

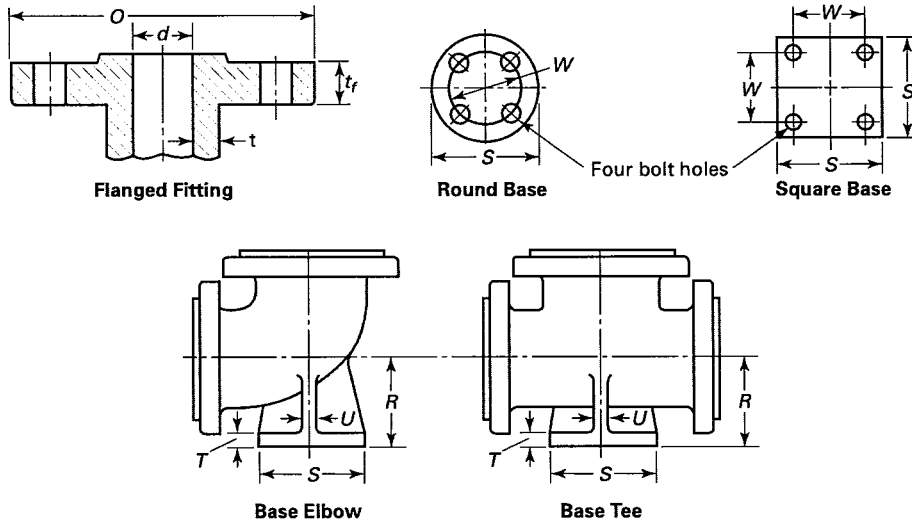

13	14	15	16	17	18	19	20	21	22	23	1
Ring Joint [Note (5)]									Base Drilling [Note (11)]		
Center-to-End Long Radius Elbow, JJ [Note (7)]	Center-to-End 45-deg Elbow, KK [Note (7)]	Long Center-to-End Lateral, LL [Note (7)]	Short Center-to-End Lateral and True "Y," MM [Note (7)]	End-to-End Reducer, NN	Center-to-Base, R [Notes (7)-(9)]	Diameter of Round Base or Width of Square Base, S [Note (7)]	Thickness of Base, T [Notes (7)-(10)]	Thickness of Ribs, U [Note (7)]	Bolt Circle or Bolt Spacing, W	Diameter of Drilled Holes	Nominal Pipe Size, NPS
5.25	2.50	6.75	2.25	1
5.75	2.75	7.50	2.50	1 1/4
6.25	3.00	8.75	2.75	1 1/2
6.81	3.31	9.31	2.81	...	4.50	5.25	0.75	0.50	3.88	3/4	2
7.31	3.81	10.81	2.81	...	4.75	5.25	0.75	0.50	3.88	3/4	2 1/2
8.06	3.81	11.31	3.31	...	5.25	6.12	0.81	0.62	4.50	7/8	3
8.81	4.31	12.81	3.31	...	5.62	6.12	0.81	0.62	4.50	7/8	3 1/2
9.31	4.88	13.81	3.31	...	6.00	6.50	0.88	0.62	5.00	3/4	4
10.56	5.31	15.31	3.81	...	6.75	7.50	1.00	0.75	5.88	7/8	5
11.81	5.81	17.81	4.31	...	7.50	7.50	1.00	0.75	5.88	7/8	6
14.31	6.31	20.81	5.31	...	9.00	10.00	1.25	0.88	7.88	7/8	8
16.81	7.31	24.31	5.81	...	10.50	10.00	1.25	0.88	7.88	7/8	10
19.31	8.31	27.81	6.31	...	12.00	12.50	1.44	1.00	10.62	7/8	12
21.81	8.81	31.31	6.81	...	13.50	12.50	1.44	1.00	10.62	7/8	14
24.31	9.81	34.81	7.81	...	14.75	12.50	1.44	1.12	10.62	7/8	16
26.81	10.31	37.81	8.31	...	16.25	15.00	1.62	1.12	13.00	1	18
29.38	10.88	40.88	8.88	...	17.88	15.00	1.62	1.25	13.00	1	20
34.44	12.44	47.94	10.44	...	20.75	17.50	1.88	1.25	15.25	1 1/8	24

Table II-12 Dimensions of Class 300 Flanged Fittings (Cont'd)

GENERAL NOTES:

- (a) Dimensions of Table II-12 are in inches.
- (b) For tolerances, see section 7.
- (c) For facings, see para. 6.4.
- (d) For flange bolt holes, see para. 6.5 and Table II-10.
- (e) For spot facing, see para. 6.6.
- (f) For intersecting centerlines, center-to-contact surface, and center-to-end dimensions of side outlet fittings, see para. 6.2.4.
- (g) For center-to-contact surface and center-to-end dimensions of special degree elbows, see para. 6.2.5.
- (h) For reinforcement of certain fittings, see para. 6.1.1.
- (i) For drains, see para. 6.12.

NOTES:

- (1) These fittings may be supplied with a flat face flange. The flat face may be either the full t_f dimension thickness plus 0.06 in. or the t_f dimension thickness without the raised face height. See para. 6.3.2 for additional restrictions.
- (2) The thickness of the flange dimension illustrated is for regularly furnished 0.06-in. raised face (except lapped); for thickness requirements of other facings, see Figure II-6.
- (3) The thickness of flange minimum dimensions for loose flanges, Table 9, size NPS 3½ and smaller are slightly heavier than for flanges on these fittings that are reinforced by being cast integral with the body of fitting.
- (4) For center-to-contact surface and center-to-end dimensions of reducing fittings, see para. 6.2.3.
- (5) For contact surface-to-contact surface and end-to-end dimensions of reducers and eccentric reducers, see para. 6.2.3.
- (6) These dimensions apply to straight sizes only (see paras. 6.2.3 and 6.4.2.2). For center-to-end dimensions of reducing fittings or end-to-end dimensions of reducers, use center-to-contact surface or contact surface-to-contact surface dimensions of 0.06-in. raised face (flange edge) for the largest opening, and add the proper height to provide for the ring joint groove applying to each flange. See Table II-5 for ring joint facing dimensions.
- (7) The base dimensions apply to all straight and reducing sizes.
- (8) The reducing fittings, the size, and center-to-face dimension of base are determined by the size of the largest opening of fittings. In the case of reducing base elbows, orders shall specify whether the base shall be opposite the larger or smaller opening.
- (9) Bases shall be plain faced unless otherwise specified, and the center-to-base dimension R shall be the finished dimension.
- (10) Bases may be cast integral or attached as weldments at the option of the manufacturer.
- (11) The bolt hole template for round base is the same as for Class 300 flanges (Table 11) of corresponding outside diameter, except using only four holes in all cases so placed as to straddle centerlines. The bases of these fittings are intended for support in compression and are not for anchors or supports in tension or shear.

(17)

Table II-13 Templates for Drilling Class 400 Pipe Flanges

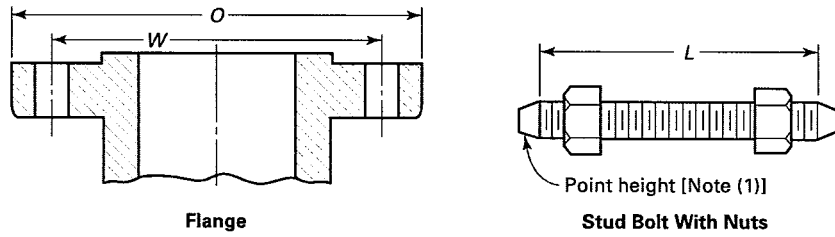

1	2	3	4	5	6	7	8	9
Nominal Pipe Size	Outside Diameter of Flange, <i>O</i>	Drilling [Notes (2), (3)]				Length of Bolts, <i>L</i> [Notes (1), (4)]		
		Diameter of Bolt Circle, <i>W</i>	Diameter of Bolt Holes	Number of Bolts	Diameter of Bolts	Raised Face 0.25 in.	Male and Female/Tongue and Groove	Ring Joint
1/2								
3/4								
1								
1 1/4								
1 1/2								
Use Class 600 dimensions in these sizes								
2								
2 1/2								
3								
3 1/2								
4	10.00	7.88	1	8	7/8	5.50	5.25	5.50
5	11.00	9.25	1	8	7/8	5.75	5.25	5.75
6	12.50	10.62	1	12	7/8	6.00	5.75	6.00
8	15.00	13.00	1 1/8	12	1	6.75	6.50	6.75
10	17.50	15.25	1 1/4	16	1 1/8	7.50	7.25	7.50
12	20.50	17.75	1 3/8	16	1 1/4	8.00	7.75	8.00
14	23.00	20.25	1 3/8	20	1 1/4	8.25	8.00	8.25
16	25.50	22.50	1 1/2	20	1 3/8	8.75	8.50	8.75
18	28.00	24.75	1 1/2	24	1 3/8	9.00	8.75	9.00
20	30.50	27.00	1 5/8	24	1 1/2	9.50	9.25	9.75
22	33.00	29.25	1 3/4	24	1 5/8	10.00	9.75	10.25
24	36.00	32.00	1 7/8	24	1 3/4	10.50	10.25	11.00

GENERAL NOTES:

- (a) Dimensions are in inches.
- (b) For other dimensions, see Table II-14.

NOTES:

- (1) The length of the stud bolt does not include the height of the points (see para. 6.10.2).
- (2) For flange bolt holes, see para. 6.5.
- (3) For spot facing, see para. 6.6.
- (4) Bolt lengths not shown in the table may be determined in accordance with Nonmandatory Appendix C (see para. 6.10.2).

(17)

Table II-14 Dimensions of Class 400 Flanges

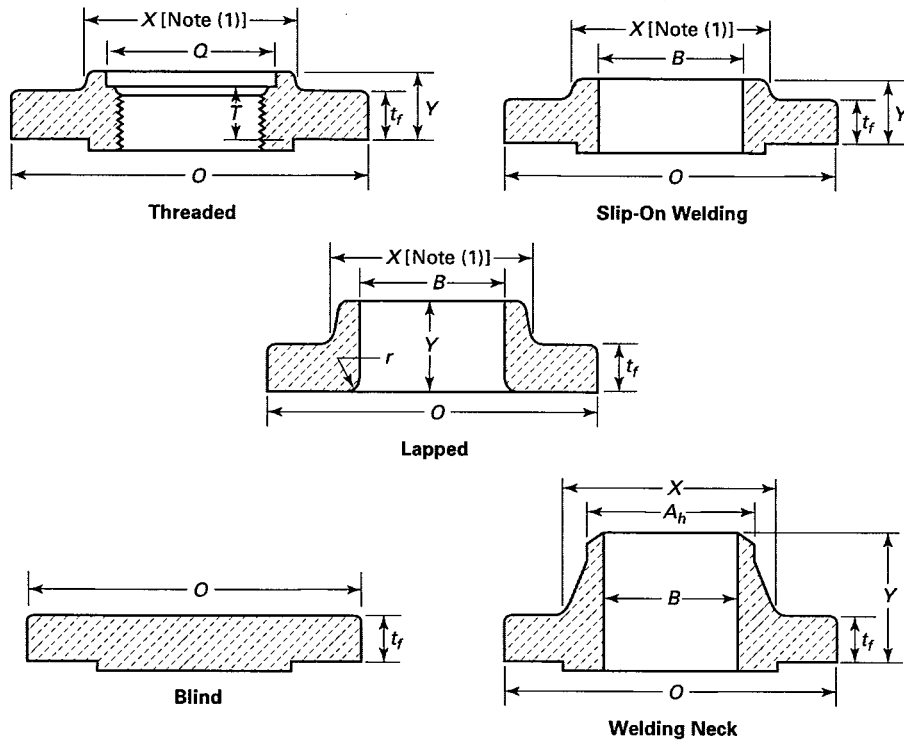

1	2	3	4	5	6			9			12	13	14
Nom. Pipe Size	Outside Diam. of Flange, O	Min. Thickness of Flange, t_f	Diam. of Hub, X	Hub Diam. Beginning of Chamfer of Neck, A_h [Note (2)]	Length Through Hub			Minimum Thread Length Threaded Flange, T [Note (3)]	Bore			Corner Bore Radius of Lapped Flange and Pipe, r	Minimum Counterbore Threaded Flange, Q
					Threaded Slip-On, Y	Lapped, Y	Welding Neck, Y		Min. Slip-On, B	Min. Lapped, B	Welding Neck, B		
$\frac{1}{2}$													
$\frac{3}{4}$													
1													
$1\frac{1}{4}$													
$1\frac{1}{2}$													
2													
$2\frac{1}{2}$													
3													
$3\frac{1}{2}$													
4	10.00	1.38	5.75	4.50	2.00	2.00	3.50	1.44	4.57	4.60	Note (5)	0.44	4.63
5	11.00	1.50	7.00	5.56	2.12	2.12	4.00	1.69	5.66	5.69	Note (5)	0.44	5.69
6	12.50	1.62	8.12	6.63	2.25	2.25	4.06	1.81	6.72	6.75	Note (5)	0.50	6.75
8	15.00	1.88	10.25	8.63	2.69	2.69	4.62	2.00	8.72	8.75	Note (5)	0.50	8.75
10	17.50	2.12	12.62	10.75	2.88	4.00	4.88	2.19	10.88	10.92	Note (5)	0.50	10.88
12	20.50	2.25	14.75	12.75	3.12	4.25	5.38	2.38	12.88	12.92	Note (5)	0.50	12.94
14	23.00	2.38	16.75	14.00	3.31	4.62	5.88	2.50	14.14	14.18	Note (5)	0.50	14.19
16	25.50	2.50	19.00	16.00	3.69	5.00	6.00	2.69	16.16	16.19	Note (5)	0.50	16.19
18	28.00	2.62	21.00	18.00	3.88	5.38	6.50	2.75	18.18	18.20	Note (5)	0.50	18.19
20	30.50	2.75	23.12	20.00	4.00	5.75	6.62	2.88	20.20	20.25	Note (5)	0.50	20.19

Use Class 600 dimensions in these sizes [Note (4)]

(17)

Table II-14 Dimensions of Class 400 Flanges (Cont'd)

1	2	3	4	5	6			8	9	10			12	13	14
Nom. Pipe Size	Outside Diam. of Flange, <i>O</i>	Min. Thickness of Flange, <i>t_f</i>	Diam. of Hub, <i>X</i>	Hub Diam. Beginning of Chamfer of Welding Neck, <i>A_h</i> [Note (2)]	Length Through Hub			Welding Neck, <i>Y</i>	Minimum Thread Length Threaded Flange, <i>T</i> [Note (3)]	Bore			Corner Bore Radius of Lapped Flange and Pipe, <i>r</i>	Minimum Counterbore Threaded Flange, <i>Q</i>	
					Threaded Slip-On, <i>Y</i>	Lapped, <i>Y</i>				Min. Slip-On, <i>B</i>	Min. Lapped, <i>B</i>	Welding Neck, <i>B</i>			
22	33.00	2.88	25.25	22.00	4.25	6.00	6.75	...	22.22	22.25	Note (5)	0.50	...		
24	36.00	3.00	27.62	24.00	4.50	6.25	6.88	3.25	24.25	24.25	Note (5)	0.50	24.19		

GENERAL NOTES:

- (a) Dimensions are in inches.
- (b) For tolerances, see section 7.
- (c) For facings, see para. 6.4.
- (d) For flange bolt holes, see para. 6.5 and Table II-13.
- (e) For spot facing, see para. 6.6.
- (f) For reducing threaded and slip-on flanges, see Table II-6.
- (g) Blind flanges may be made with or without hubs at the manufacturer's option.
- (h) For reducing welding neck flanges, see para. 6.8.

NOTES:

- (1) This dimension is for the large end of the hub, which may be straight or tapered. Taper shall not exceed 7 deg on threaded, slip-on, and lapped flanges.
- (2) For welding end bevel, see para. 6.7.
- (3) For thread in threaded flanges, see para. 6.9.
- (4) Socket welding flanges may be provided in NPS 1/2 through 2 1/2 using Class 600 dimensions.
- (5) To be specified by the purchaser.